



WELDING STANDARDS
FOR FABRICATION OF
STEEL, STAINLESS STEEL,
AND ALUMINUM BAR
GRATING

FOURTH FIFTH EDITION



WELDING STANDARDS

For Fabrication of Steel, Stainless Steel and Aluminum Bar Grating

~~Fourth~~ Fifth Edition

NAAMM MBG 533-26

DRAFT

Published and distributed by the

NATIONAL ASSOCIATION OF ARCHITECTURAL METAL MANUFACTURERS

800 Roosevelt Road
Bldg. C, Suite 312
Glen Ellyn, Illinois 60137
Phone: (630) 942-6591
email: info@naamm.org

NAAMM'S METAL BAR GRATING DIVISION

The members of the Metal Bar Grating Division of the National Association of Architectural Metal Manufacturers have supported the preparation of this Manual. All are producers and/or suppliers of products conforming to the standards and specifications contained herein. A copy of the Membership Roster of the Metal Bar Grating Division is available from NAAMM at www.naamm.org

FOREWORD

The NAAMM Welding Standards for Fabrication of Steel, Stainless Steel and Aluminum Bar Grating provide architects and engineers with current technical data on bar grating and stair treads. The information contained is based on sound engineering principles and reflects practices recommended by leading manufacturers in the industry.

The first ~~three-four~~ editions of the manual have been widely used by design professional. In preparing this ~~fourth-fifth~~ edition, the Metal Bar Grating Division of NAAMM has reviewed its contents in detail and has made revisions to reflect current practices.

Changes from the previous edition, ANSI/NAAMM MBG 533-~~09-21~~ are indicated by the placement of a vertical line next to the changed item.

CONTENTS

Section 1. General Provisions	1
Section 2. Design of Welded Connections	
Welding Standards for Standard Grating.....	3
Welding Standards for Heavy Duty Grating.....	4
Welding Standards for Close-Mesh Grating	6
Welding Standards for Standard Stair Treads.....	8
Welding Standards for Plate Attachment to Grating	8
Section 3. Workmanship	9
Section 4. Filler Metal and Shielding Gas.....	11
Section 5. Qualification	
Part I. General Requirements	12
Part II. Procedure Qualification	12
Part III Welder, Welding Operator and Tacker	14
Part IV Qualification Forms.....	15

Approval of an American National Standard requires verification by ANSI that the requirements for due process, consensus, and other criteria for approval have been met by the standards developer.

Consensus is established when, in the judgment of the ANSI Board of Standards Review, substantial agreement has been reached by directly and materially affected interests. Substantial agreement means much more than a simple majority, but not necessarily unanimity. Consensus requires that all views and objections be considered, and that a concerted effort be made toward their resolution.

The use of American National Standards is completely voluntary, their existence does not in any respect preclude anyone, whether he has approved the standards or not, from manufacturing, marketing, purchasing, or using products, processes, or procedures not conforming to the standards.

The American National Standards Institute does not develop standards and will in no circumstances give an interpretation of any American National Standard. Moreover, no person shall have the right or authority to issue an interpretation of an American National Standard in the name of the American National Standards Institute. Requests for interpretation should be addressed to the sponsor whose name appears on the title page of this standard.

CAUTION NOTICE: This American National Standard may be revised or withdrawn at any time. The procedures of the American National Standards Institute require that action be taken periodically to reaffirm, revise, or withdraw this standard. Purchasers of American National Standards may receive current information on all standards by calling or writing the American National Standards Institute.

This standard was developed by representative members of the Metal Bar Grating Division (MBG) of the National Association of Architectural Metal Manufacturers (NAAMM) to provide their opinion and guidance on the welding of metal bar gratings. This standard contains advisory information only and is published as a public service by NAAMM. NAAMM and its Divisions disclaim all liability of any kind for the use, application, or adaptation of material published in this standard.

Current information on all NAAMM Standards is available by calling or writing the National Association of Architectural Metal Manufacturers or by going to www.naamm.org.

National Association of Architectural Metal Manufacturers
800 Roosevelt Road
Bldg. C, Suite 312
Glen Ellyn, Illinois 60137
Phone: (630) 942-6591 Fax: (630) 790-3095
www.naamm.org

Copyright © 1979, 1989, 2009, 2021, 2026
National Association of Architectural Metal Manufacturers
All Rights Reserved

NAAMM MBG 533-26
WELDING STANDARDS FOR FABRICATION
OF
STEEL, STAINLESS STEEL AND ALUMINUM BAR GRATING

SECTION 1

GENERAL PROVISIONS

1.1 APPLICATIONS

This Standard covers fillet welding requirements as they apply to bar grating made of steel, aluminum and stainless steel. The provisions cover banding, toe plates, treads, and miscellaneous material. (See welding standards in NAAMM Metal Bar Grating Manual, ANSI/NAAMM MBG 531 and NAAMM Heavy Duty Metal Bar Grating Manual, ANSI/NAAMM MBG 532, latest editions.) The provisions are not intended to cover high stress structural welds. If conditions should require such welding, the applicable provisions of the American Welding Society Structural Welding Codes, AWS-D1.1 for carbon and low alloy steel, except for Section 5.4.4 AWS-D1.2 for aluminum, AWS-D1.6 for stainless steel, and AWS-D1.5 for bridge welding, latest editions to be applied.

1.2 BASE METAL

- 1.2.1** Metals to be welded under this Standard shall conform with the requirements of the latest edition of one of the following specifications. Combinations of these steel base metals may be welded together.
- 1.2.1.1** ASTM A 36 / A 36M Standard Specification for Carbon Structural Steel. (For bars only)
- 1.2.1.2** ASTM A 510 (ASTM A 510M) Standard Specification for General Requirements for Wire Rods and Coarse Round Wire, Carbon Steel, and Alloy Steel.
- 1.2.1.3** ASTM A 606 Standard Specification for Steel, Sheet and Strip, High Strength, Low Alloy, Hot-Rolled and Cold-Rolled with Improved Atmospheric Corrosion Resistance.
- 1.2.1.4** ASTM A 666 Standard Specification for Annealed or Cold-Worked Austenitic Stainless Steel Sheet, Strip, Plate and Flat Bar. Type 304, 304L, 316 or 316L Alloy.
- 1.2.1.5** ASTM A 1011 / A 1011 M Standard Specification for Steel, Sheet and Strip, Hot-Rolled, Carbon, Structural, High-Strength Low Alloy, High-Strength Low-Alloy with Improved Formability, and Ultra-High Strength. CS Type B, SS Grade 36.
- 1.2.1.6** ASTM A 1018 / A 1018 M Standard Specification for Steel, Sheet and Strip, Heavy-Thickness Coils, Hot-Rolled, Carbon, Commercial, Drawing, Structural, High-Strength Low Alloy, High-Strength Low-Alloy with Improved Formability, and Ultra-High Strength Steel. SS Grade 36.
- 1.2.1.7** ASTM B 221 (ASTM B 221M) Standard Specification for Aluminum and Aluminum-Alloy Rolled or cold finished Bar, Rod and Wire. Alloys 6061-T6, 6063-T6, 6005-T6, and 6105-T5.
- 1.2.2** When metals other than those listed in 1.2.1 are specified, the weldability of the metal and the procedure for welding it shall be established by the customer.

1.3 WELDING PROCESS

Shielded metal-arc (SMAW) and gas metal-arc welding (GMAW) procedures are considered prequalified and approved for use without performing procedure qualification tests.

1.4 DEFINITIONS

The welding terms used in this Standard shall be interpreted in accordance with the definitions given in the latest edition of Terms and Definitions (AWS A3.0) of the American Welding Society.

1.5 WELDING SYMBOLS

Welding symbols shall be those shown in the latest edition of Standard Welding Symbols (AWS A2.4) of the American Welding Society. Special welding conditions shall be fully explained by added notes or details on drawings.

1.6 SAFETY PRECAUTIONS

Safety precautions shall conform to the latest edition of ANSI Z49.1, Safety in Welding, Cutting, and Allied Processes published by the American Welding Society. This code may not address all hazards with welding and should not be considered all inclusive.

DRAFT

SECTION 2

DESIGN OF WELDED CONNECTIONS

2.1 WELDING STANDARDS

Figures 2.1.1, 2.1.2, 2.1.3, 2.1.4, 2.1.5, 2.1.6, 2.1.7, 2.1.8, 2.1.9, 2.1.10, 2.1.11, and 2.1.12 cover welding standards for bar gratings. These standards apply to steel, aluminum and stainless steel gratings and treads and to steel gratings galvanized as per specifications set forth in ANSI/NAAMM MBG 531 or ANSI/NAAMM MBG 532.

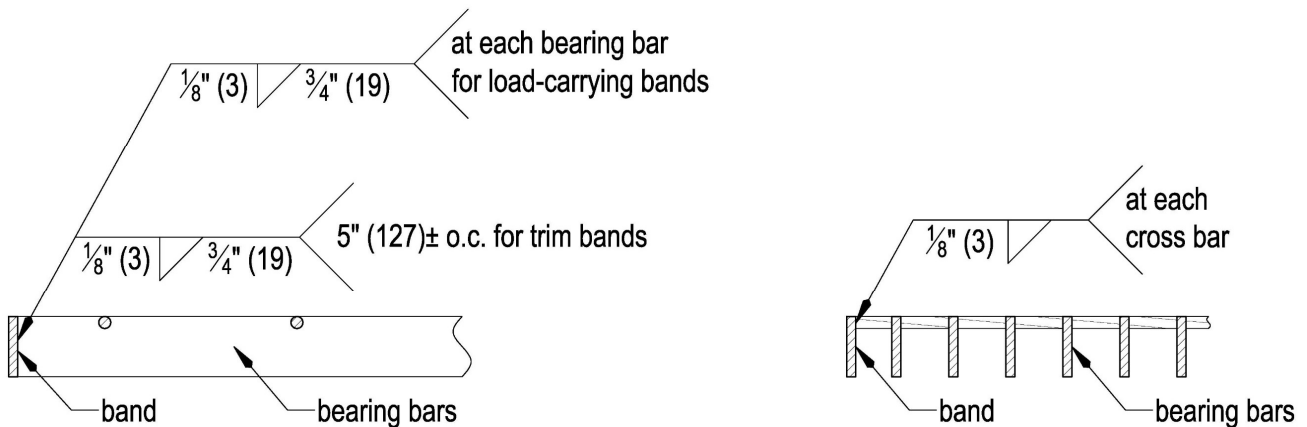

Figure 2.1.1 - BANDING FOR STANDARD GRATING
 (bearing bar thickness less than 1/4" (6mm) and bearing bar clear opening greater than or equal to 5/8" (16mm))

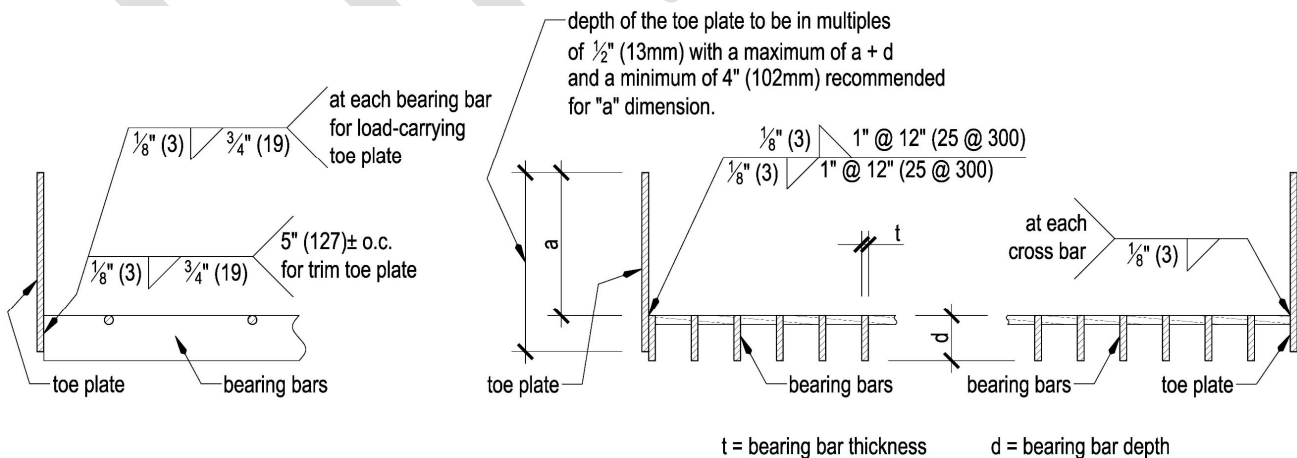

Figure 2.1.2 - TOE PLATE FOR STANDARD GRATING
 (bearing bar thickness less than 1/4" (6mm) and bearing bar clear opening greater than or equal to 5/8" (16mm))

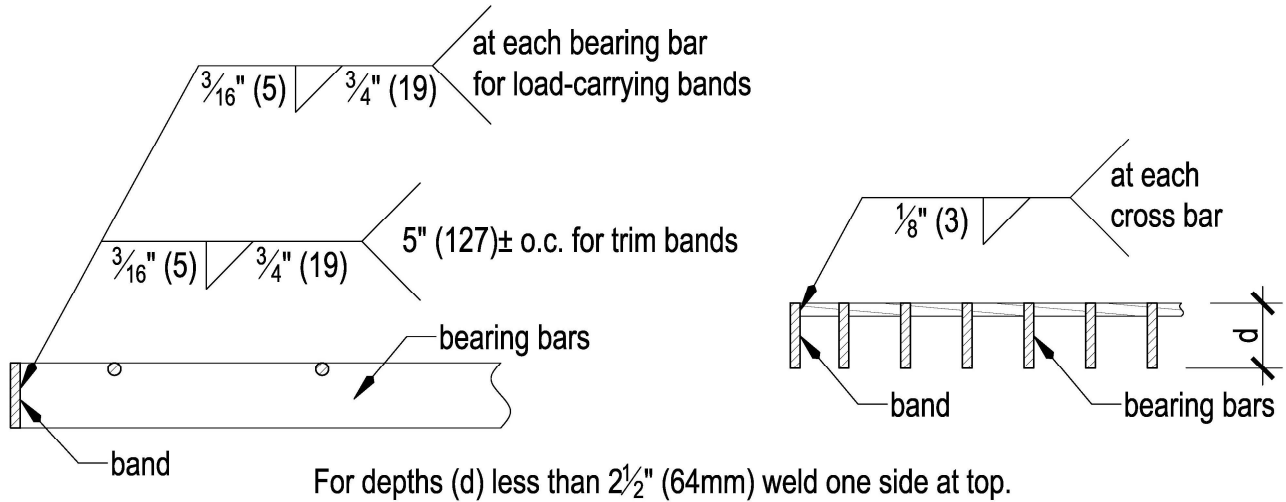
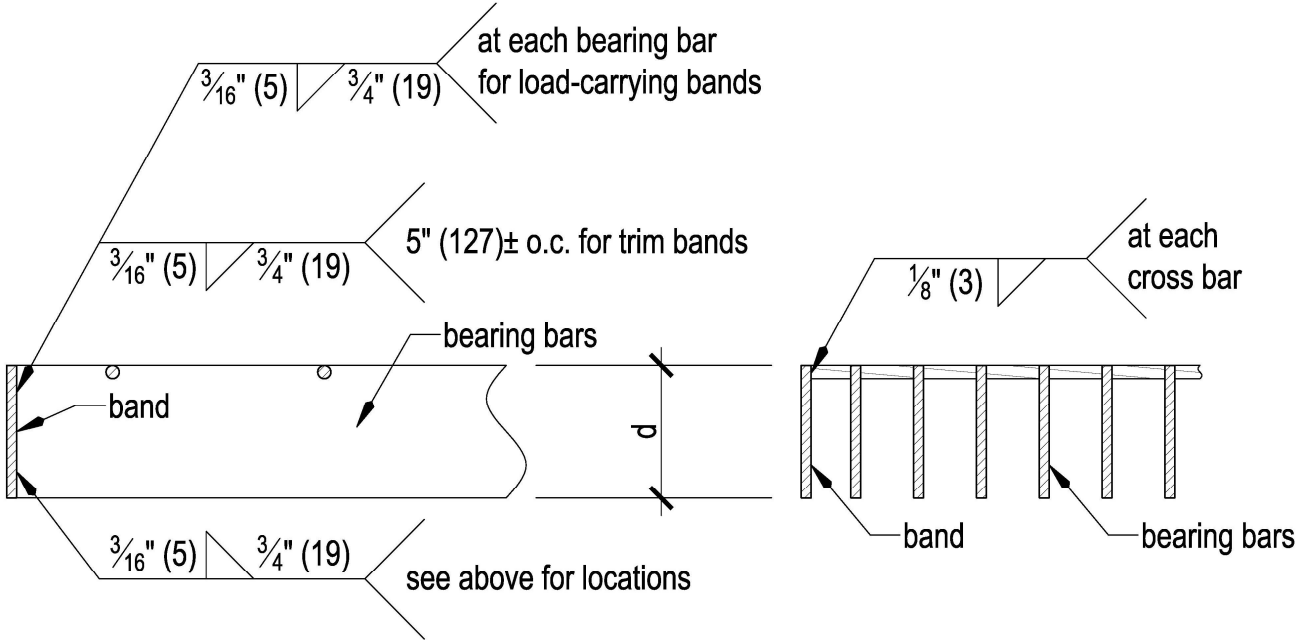

Figure 2.1.3 - BANDING FOR HEAVY DUTY GRATING LESS THAN 2 1/2" DEEP
 (bearing bar thickness $\frac{3}{8}$ " (6mm) and greater and bearing bar clear opening greater than or equal to $\frac{5}{8}$ " (16mm))



For depths (d) $2\frac{1}{2}$ " (64mm) or greater, weld one side at top, opposite side at bottom.
 Or weld exceeding one-half depth on one side only.

Figure 2.1.4 - BANDING FOR HEAVY DUTY GRATING 2 1/2" DEEP AND GREATER
 (bearing bar thickness $\frac{3}{8}$ " (6mm) and greater and bearing bar clear opening greater than or equal to $\frac{5}{8}$ " (16mm))

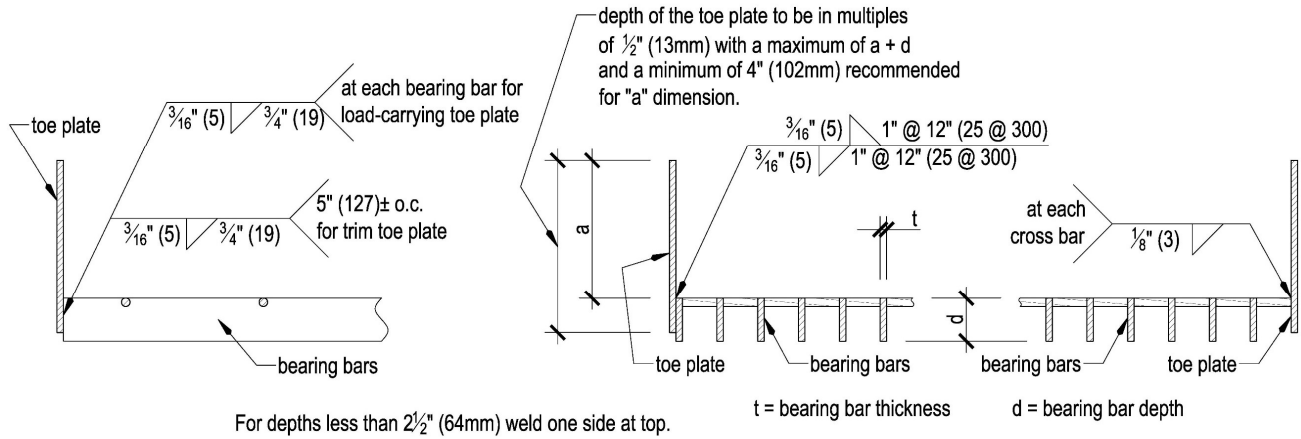

Figure 2.1.5 - TOE PLATE FOR HEAVY DUTY GRATING LESS THAN 2 1/2" DEEP
(bearing bar thickness $\frac{1}{8}$ "(6mm) and greater and bearing bar clear opening greater than or equal to $\frac{5}{8}$ "(16mm))

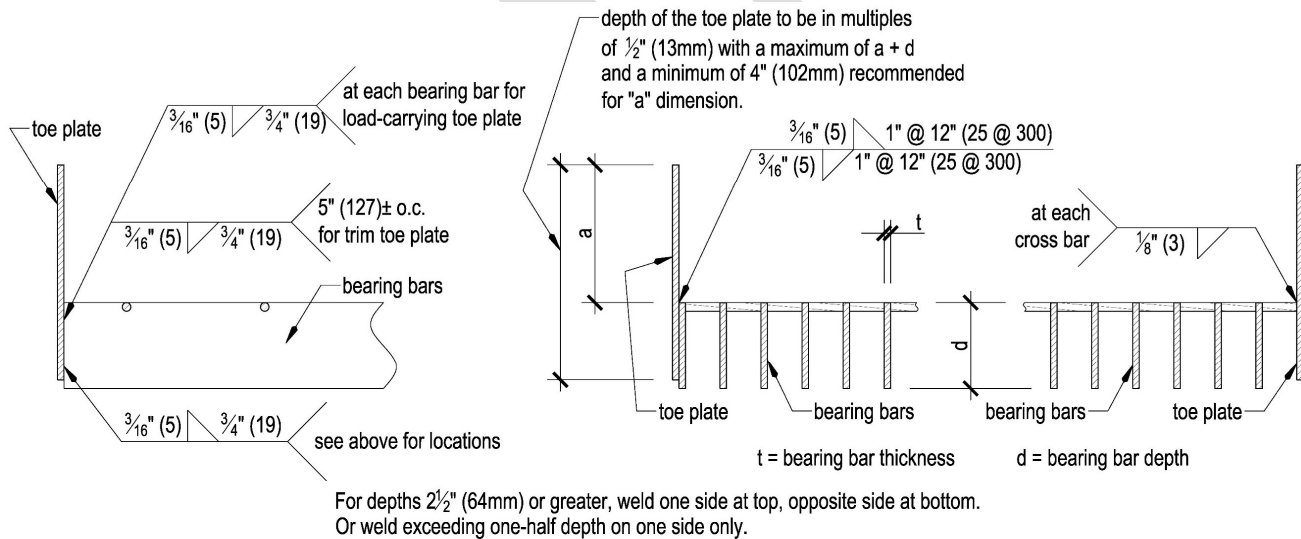
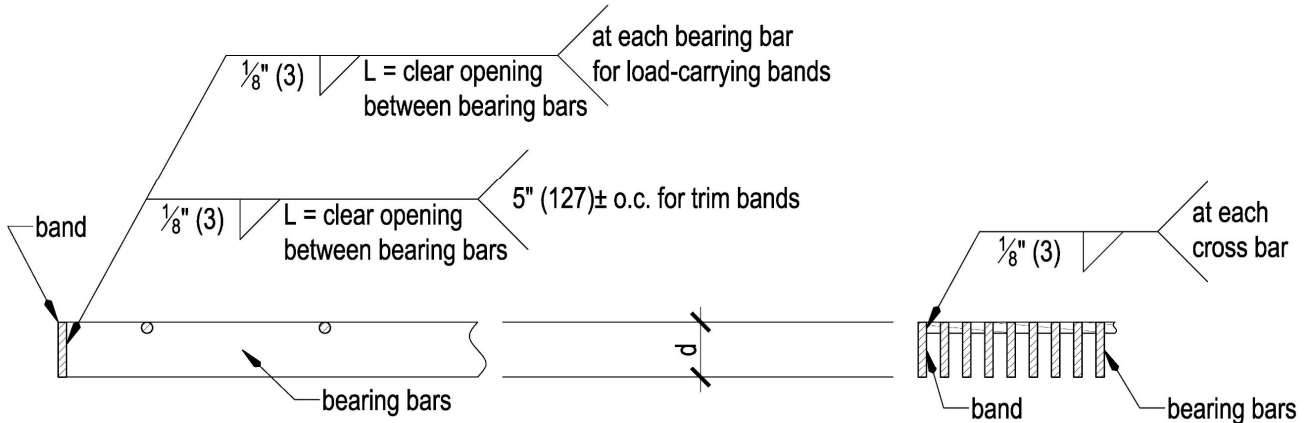

Figure 2.1.6 - TOE PLATE FOR HEAVY DUTY GRATING 2 1/2" DEEP AND GREATER
(bearing bar thickness $\frac{1}{8}$ "(6mm) and greater and bearing bar clear opening greater than or equal to $\frac{5}{8}$ "(16mm))



For depths (d) less than 2" (51mm) weld one side at top.

Note: For aesthetic applications specify weld placement. Plug welding may be used as an alternate to fillet welding.

Figure 2.1.7 - BANDING FOR CLOSE MESH GRATING LESS THAN 2" DEEP
 (all grating and treads with bearing bars having a clear opening less than 5/8" (16mm))

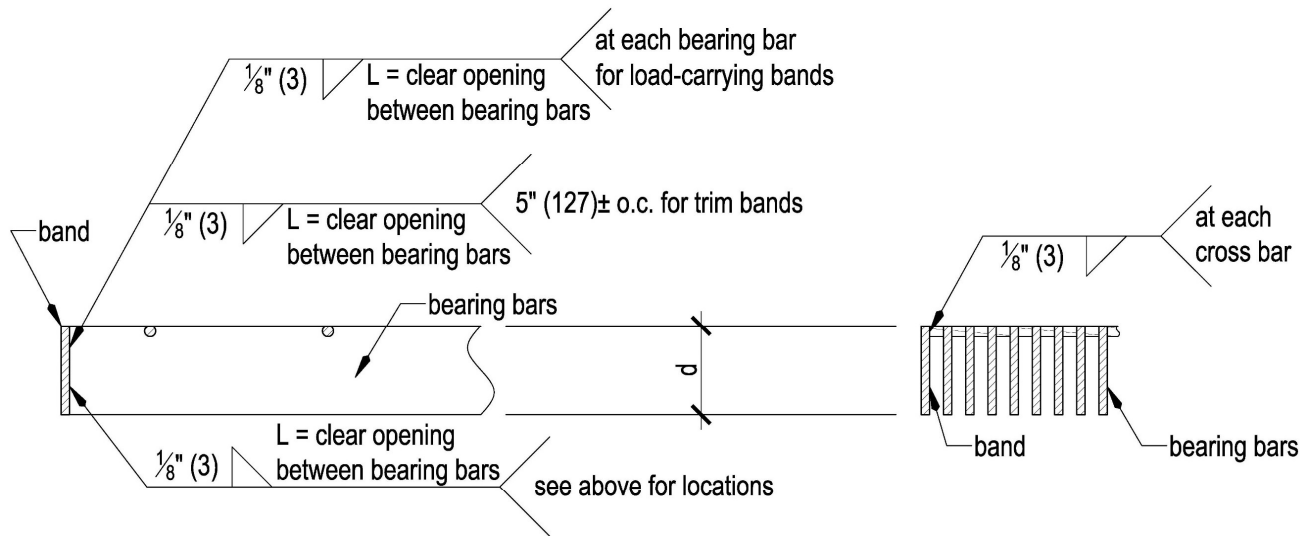

For depths (d) 2" (51mm) or greater weld one side at top, opposite side at bottom.

Note: For aesthetic applications specify weld placement. Plug welding may be used as an alternate to fillet welding.

Figure 2.1.8 - BANDING FOR CLOSE MESH GRATING 2" DEEP AND GREATER
 (all grating and treads with bearing bars having a clear opening less than 5/8" (16mm))

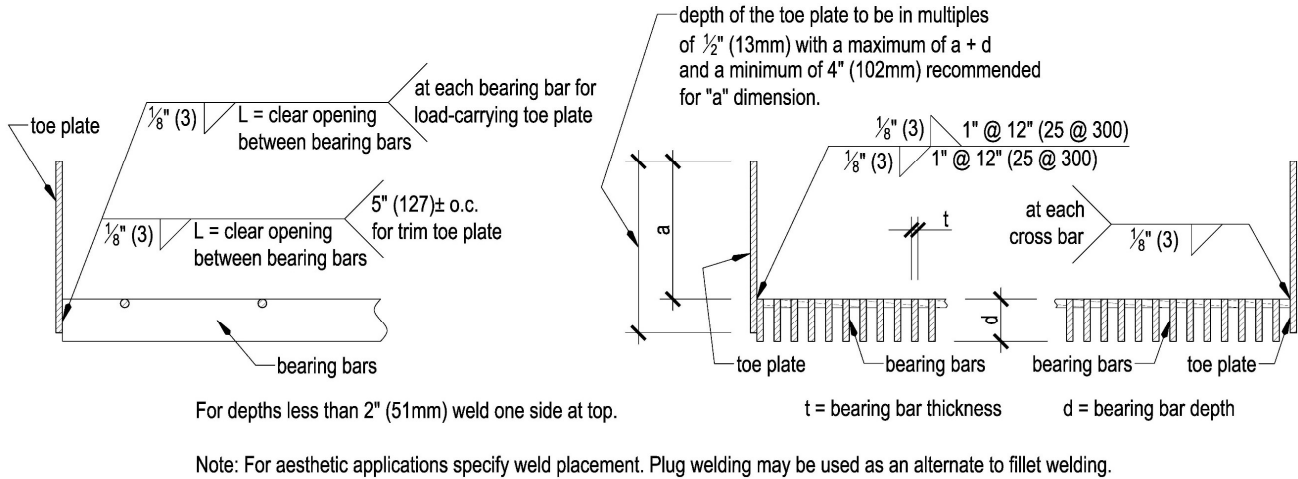

Figure 2.1.9 - TOE PLATE FOR CLOSE MESH GRATING LESS THAN 2" DEEP
(all grating with bearing bars having a clear opening less than $\frac{5}{8}$ " (16mm))

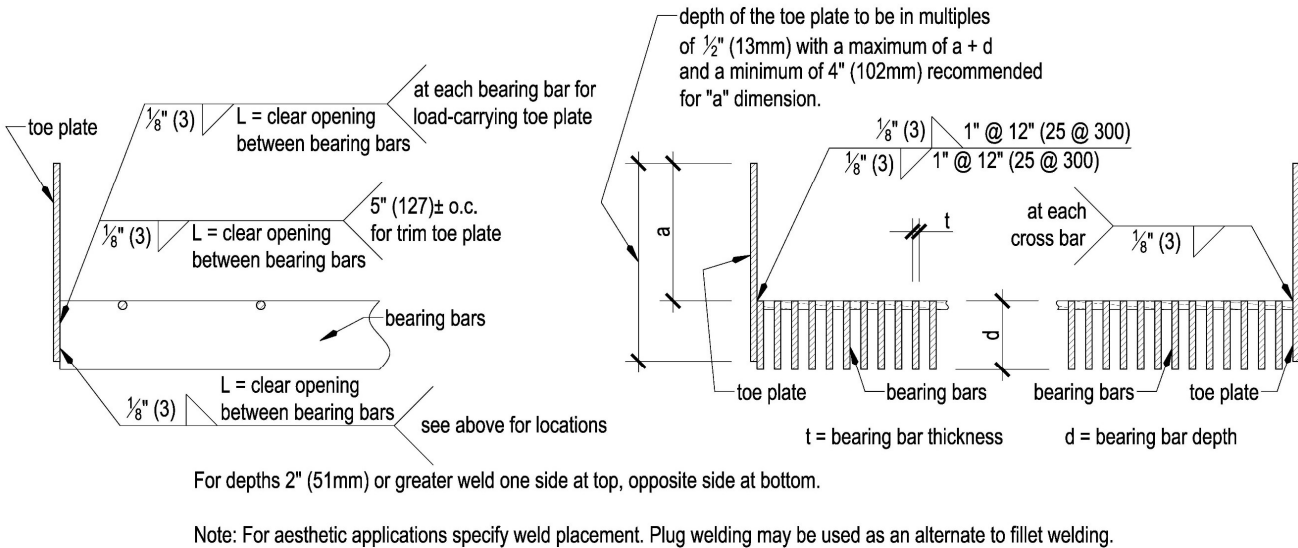

Figure 2.1.10 - TOE PLATE FOR CLOSE MESH GRATING 2" DEEP AND GREATER
(all grating with bearing bars having a clear opening less than $\frac{5}{8}$ " (16mm))

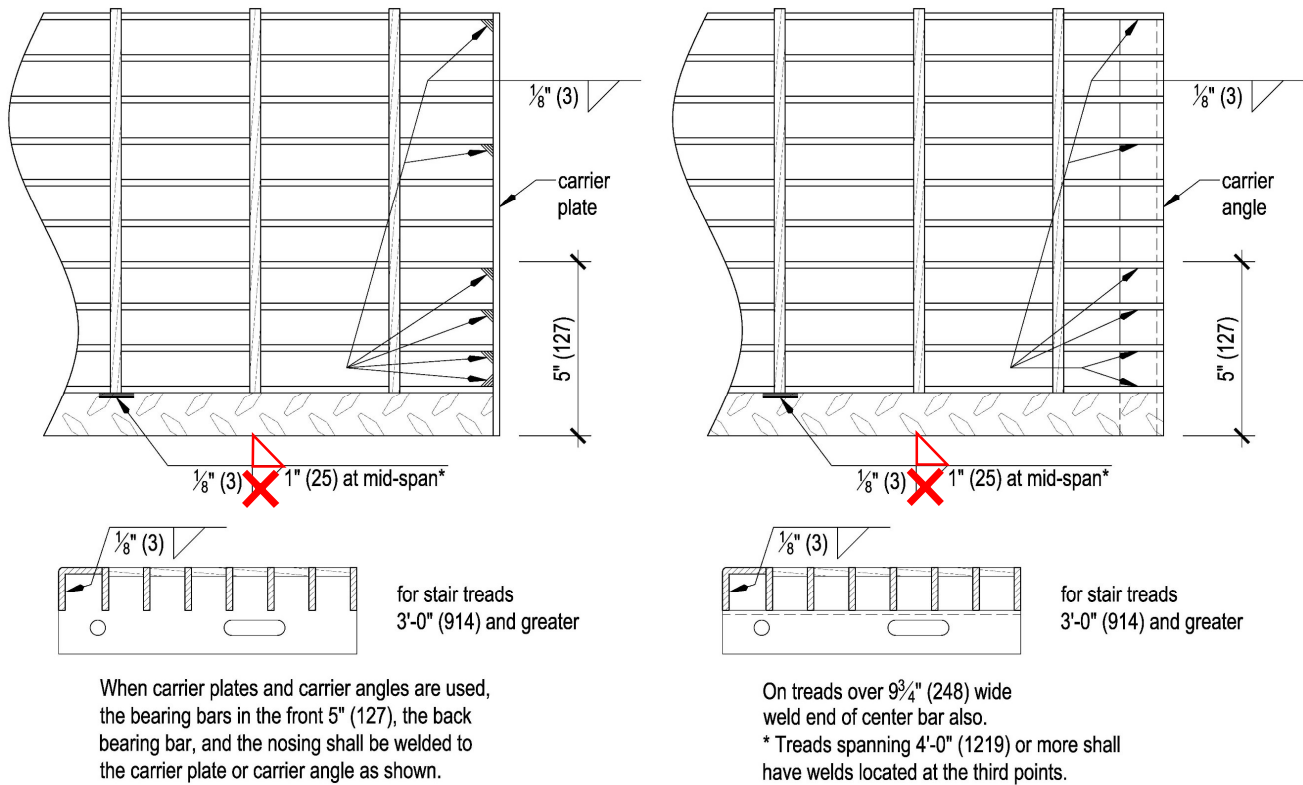
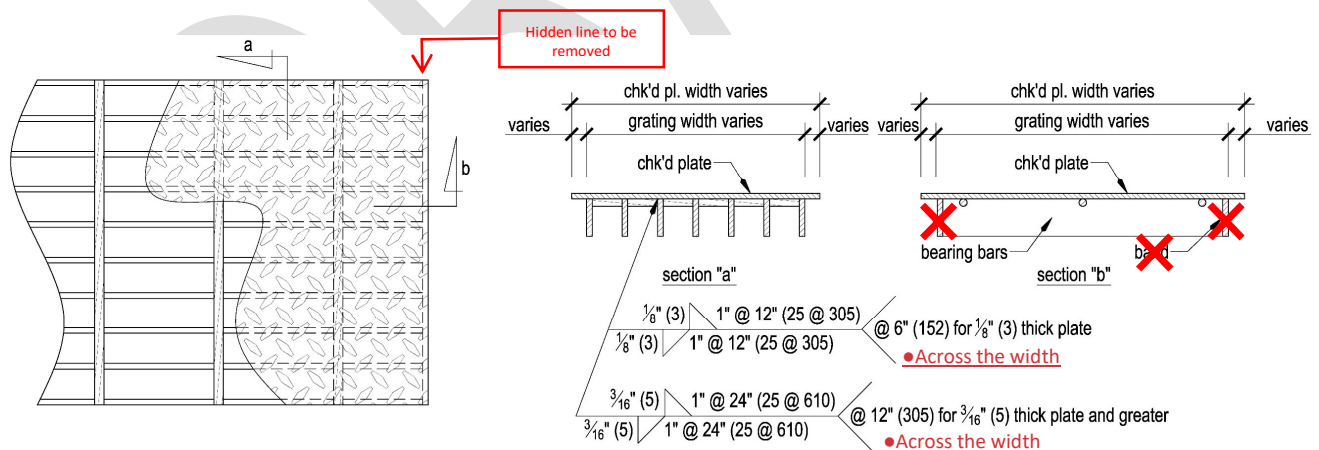

Figure 2.1.11 - STANDARD STAIR TREADS
 (bearing bar thickness less than 1/4" (6mm) and bearing bar clear opening greater than or equal to 5/8" (16mm))



2.2 DRAWINGS

When there are no special requirements indicated by the customer, the Welding Standards covered by 2.1 shall apply and no additional information need be shown on the drawings. For other requirements, the drawings shall show full and complete information regarding location, type, size, and extent of all welds.

SECTION 3

WORKMANSHIP

3.1 GENERAL

- 3.1.1 All pertinent paragraphs of this section shall apply in the production and inspection of welded assemblies produced by any of the processes acceptable under this Standard.
- 3.1.2 All items of equipment for welding and oxygen cutting shall be so designed and manufactured, and be in such condition, as to enable qualified welders and tackers to follow the procedures and attain the results prescribed in this Standard.
- 3.1.3 No welding shall be done when the ambient temperature is lower than 0°F (-18°C), when surfaces are wet or exposed to rain, snow, wind in excess of 5 mph (8 km/h) (GMAW only) or when welders are exposed to inclement conditions without proper shelter.
- 3.1.4 The sizes and lengths of welds shall not be less than those specified in 2.1 or as shown on detail drawings. The location of welds shall not be changed without approval of the customer.

3.2 PREPARATION OF BASE METAL

- 3.2.1 Surfaces of steel to be welded and surfaces adjacent to the weld shall be free of loose or thick scale, slag, rust, moisture, grease, or other foreign material that will prevent proper welding. Mill scale that withstands vigorous wire brushing, a thin rust inhibitive coating, or anti-spatter compound need not be removed.
- 3.2.2 Surfaces of aluminum and stainless steel to be welded and surfaces adjacent to the weld shall be free of moisture, grease or other foreign material that will prevent proper welding.
- 3.2.3 In all oxygen cutting, the cutting flame shall be so adjusted and manipulated as to avoid cutting beyond (inside) the prescribed lines. Roughness of oxygen cut surfaces shall not be greater than that defined by ANSI/ASME B46.1 as having a surface roughness value of 2000 ~~micro-in~~micro inches. Roughness exceeding this value and occasional notches or gouges shall be removed by grinding. Cut surfaces and edges shall be left free of cutting dross or slag that will have an adverse effect on the weld.

3.3 ASSEMBLY

- 3.3.1 The parts to be joined shall be brought into as close contact as practicable.
- 3.3.1.1 For galvanized parts refer to ASTM A 385 Practice for Providing High-Quality Zinc Coatings (Hot Dip).

3.3.2 TACK WELDS

- 3.3.2.1 Tack welds shall be subject to the same requirements as the final welds except that preheat is not mandatory for single pass tack welds which are remelted and incorporated into the final welds.
- 3.3.2.2 Tack welds which are to be incorporated into the final welds shall be made with electrodes meeting the requirements of the final weld.
- 3.3.2.3 Tack welds not incorporated into final welds need not be removed but shall be made with electrodes meeting the requirements of the final weld.

3.4 CONTROL OF DISTORTION AND SHRINKAGE

- 3.4.1 In assembling parts the procedure and sequence shall be such as will minimize distortion and shrinkage.
- 3.4.2 Insofar as practicable, all welds shall be deposited in a sequence that will balance the applied heat of welding while the welding progresses.
- 3.4.3 The welding sequences used shall be such as will produce assemblies meeting the quality requirements specified.

3.5 DIMENSIONAL TOLERANCES

The dimensions of the final welded assembly shall be within the manufacturing tolerances established in ANSI/NAAMM MBG 531 or ANSI/NAAMM MBG 532.

3.6 WELD PROFILES

The faces of the fillet welds may be slightly convex, flat, or slightly concave as shown in Fig. 3.6, Details A, B, and C. Except at outside corner joints, the convexity shall not exceed that shown in Fig. 3.6, Detail C.

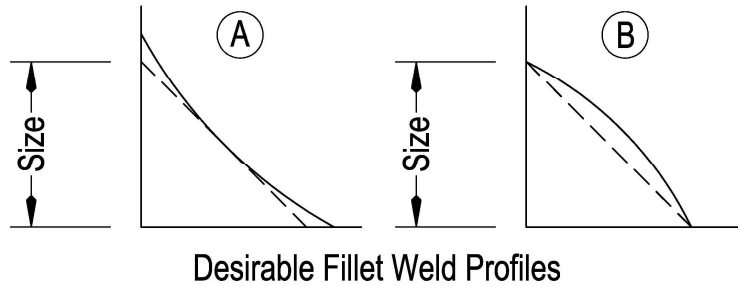

Desirable Fillet Weld Profiles

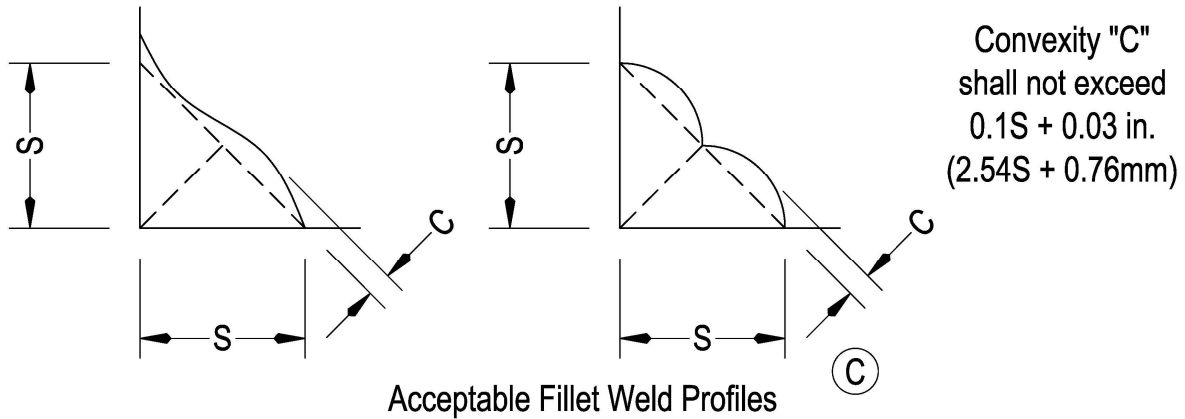

Acceptable Fillet Weld Profiles

Figure 3.6 – ILLUSTRATION OF ACCEPTABLE FILLET WELD PROFILES

3.7 CORRECTIONS

- 3.7.1 Remove excess weld metal by grinding, chipping, or air carbon arc cutting in such a manner that the remaining weld metal or base metal is not damaged. Surfaces shall be cleaned before rewelding.
- 3.7.2 Defective or unsound welds or base metal shall be corrected as follows:
 - 3.7.2.1 Overlap or excessive convexity: Reduce by removal of excess weld metal.
 - 3.7.2.2 Unacceptable concavity of weld or crater, undersize weld, undercutting: Clean and deposit additional weld metal.
 - 3.7.2.3 Unacceptable weld porosity, excessive slag inclusions, incomplete fusion: Remove defective portions and reweld.
- 3.7.3 Members distorted by welding shall be straightened by mechanical means or, in the case of steel or stainless steel, by localized heating to a temperature not exceeding 1200°F (649°C) (dull red). Localized heating shall not be used on aluminum.

3.8 CLEANING

Slag shall be cleaned from all welds.

3.9 PREHEAT TEMPERATURE REQUIREMENTS

There is no requirement for preheat temperature unless the base metal is below 32°F (0°C). If temperature of base metal is below 32°F (0°C), it shall be preheated to at least 32°F (0°C) and shall be maintained at this minimum temperature during welding.

3.10 ARC STRIKES

Arc strikes outside the area of permanent welds should be avoided on any base metal. Cracks or blemishes resulting from arc strikes shall be ground.

3.11 WELD CLEANING

Before welding over previously deposited metal all slag shall be removed and the weld and adjacent metal shall be brushed clean.

SECTION 4

FILLER METAL AND SHIELDING GAS

4.1 FILLER METAL REQUIREMENTS

4.1.1 The electrodes for carbon and low alloy steel shall meet the following specifications:

AWS A5.1 Carbon Steel Electrodes for SMAW.

AWS A5.5 Low-Alloy Steel Electrodes for SMAW.

4.1.2 The electrodes for carbon steel shall meet the following specifications:

AWS A5.18 Carbon Steel Electrodes and **RODS-RODS** for Gas Shielded Arc Welding

AWS A5.20 Carbon Steel Electrodes for Flux Cored Arc Welding

4.1.3 The electrodes for aluminum shall meet the following specifications:

AWS A5.3 Aluminum and Aluminum Alloy Covered Arc Welding Electrodes

AWS A5.10 Aluminum and Aluminum Alloy Bare Welding Rods and Electrodes

4.1.4 The electrodes for stainless steel shall meet the following specifications:

AWS A5.4 Covered Corrosion-Resisting Chromium and Chromium-Nickel Steel Welding Electrodes

AWS A5.9 Corrosion-Resisting Chromium and Chromium-Nickel Steel Bare and Composite Metal Cored and Stranded Welding Electrodes and Welding Rods

AWS A5.22 Flux Cored Corrosion-Resisting Chromium and Chromium-Nickel Steel Electrodes

4.1.5 For ASTM A 606 steel where corrosion resistance and coloring characteristics of the weld are to be similar to the base metal use the appropriate AWS A5.5 electrodes. When color match is not important but similar corrosion characteristics are required in the weld, use E70XX low-hydrogen electrodes.

4.1.6 After filler metal has been removed from its original package it shall be so protected or stored that its characteristics or welding properties are not adversely affected thus limiting intended performance.

4.2 SHIELDING GAS REQUIREMENTS

4.2.1 When a gas or gas mixture is used for shielding in gas metal arc welding, it shall be of a welding grade having a dew point of -40°F (-40°C) or lower.

4.2.2 Welding with external gas shielding shall not be done in a draft or wind having a velocity greater than 5 miles per hour (8 km/h).

SECTION 5

QUALIFICATION

PART I — GENERAL REQUIREMENTS

5.1 APPROVED PROCEDURES

- 5.1.1 Welding procedures which conform to the provisions set forth in Sections 1, 2, 3 and 4 shall be deemed as prequalified and are exempt from tests or qualification.
- 5.1.2 All prequalified welding procedures shall be described by the grating fabricator in a written procedure specification which shall be available to those authorized to examine them.

5.2 OTHER PROCEDURES

Except for the procedures exempted in 5.1, welding procedures which are to be employed in executing contract work shall be previously qualified by tests as hereinafter prescribed when so requested by the customer's specification. The customer shall accept properly documented evidence of previous qualification.

5.3 WELDERS, WELDING OPERATORS AND TACKERS

All welders, welding operators and tackers to be employed under this Standard shall have been qualified as prescribed in Parts II, III, and IV of Section 5. The customer shall accept properly documented evidence of previous qualification.

5.4 QUALIFICATION RESPONSIBILITY

Each grating fabricator shall conduct such tests as are required by this Standard to qualify the welding procedures and the welders, welding operators and tackers who will apply the procedures.

PART II — PROCEDURE QUALIFICATION

5.5 LIMITATION OF VARIABLES

- 5.5.1 When necessary to establish a welding procedure by qualification as required by 5.2 or contract specification the following rules apply and the procedure shall be recorded by the grating fabricator as a procedure specification.
- 5.5.1.1 Qualification of a welding procedure established with base metals of steel or stainless steel having a minimum specified yield point of 50,000 psi (350 MPa) shall qualify that procedure for any other base metals of steel or stainless steel (or combination of metals) having a specified yield point equal to or less than 50,000 psi (350 MPa). The applicable version and section of AWS D1.2 (for aluminum) shall be referred and followed for the selection of base metal.
- 5.5.2 The changes set forth in the following schedule shall be considered essential changes in a welding procedure and shall require establishing a new procedure by qualification.

5.5.2.1 SHIELDED METAL-ARC WELDING

- (1) A change increasing filler metal strength level; e.g., for base metal of steel, a change from E70XX to E80XX, but not vice versa.
- (2) A change from a low-hydrogen type electrode to a non-low-hydrogen type of electrode, but not vice versa.
- (3) An Increase in diameter of the electrode used, over that called for in the procedure specification.
- (4) A change of more than 15% above or below the specified mean arc voltage and amperage for each size electrode used.
- (5) A change in position in which welding is done.
- (6) A decrease of more than 25°F (4°C) in the minimum specified preheat temperature.
- (7) In the case of vertical welding, a change from the progression specified for any pass from upward to downward or vice versa.

5.5.2.2 GAS-METAL ARC WELDING

- (1) A change in electrode and method of shielding not covered by AWS specification A5.9, A5.10 and A5.18.
- (2) A change increasing filler metal strength level; e.g., for a base metal of steel, grade ~~E70S-ER70S~~ to grade ~~E80S-ER80S~~, but not vice versa.
- (3) A change in electrode diameter.
- (4) A change from a single gas to any other single gas or to a mixture of gases, or a change in specified percentage composition of gas mixture not covered by AWS A5.9, A5.10 and A5.18.
- (5) A change of more than 10% above or below the specified mean amperage for each size electrode used.
- (6) A change of more than 7 % above or below the specified mean arc voltage for each size electrode used.
- (7) A change of more than 10% above or below the specified mean travel speed.
- (8) An increase of 25% or more or a decrease of 10% or more in the rate of flow of shielding gas or mixture.
- (9) A change in position in which welding is done.
- (10) A decrease of more than 25% in the minimum specified preheat temperature.
- (11) In the case of vertical welding a change from the progression specified for any pass from upward to downward or vice versa.
- (12) A change in type of welding current (ac or dc), polarity or mode of metal transfer across arc.

5.6 TYPES OF TESTS

Fillet, or plug welds shall be subject to visual tests for soundness and quality.

5.7 BASE METAL AND ITS PREPARATION

The base metal and its preparation for welding shall comply with the procedure specification.

5.8 POSITION OF TEST WELDS

All welds in grating fabrication are horizontal or vertical. Each procedure shall be tested for each position for which it is to be qualified. Test plates shall be welded in the position outlined In Fig. 5.8.

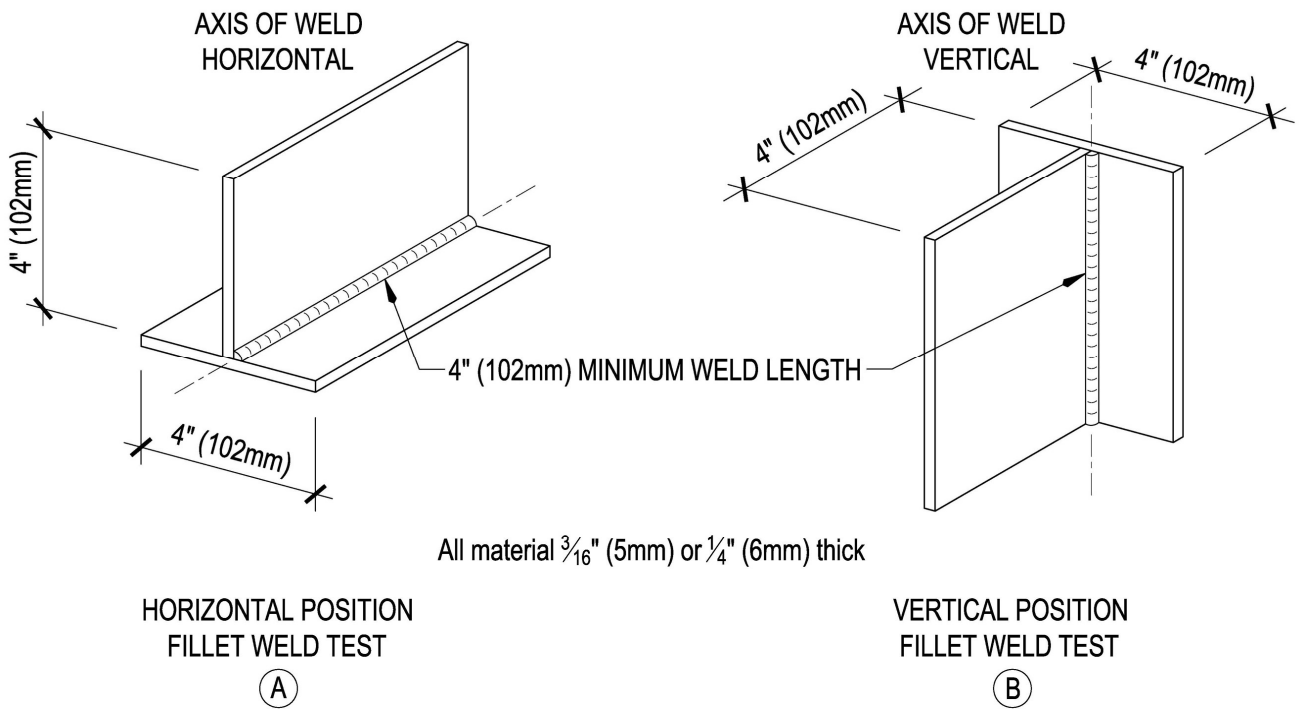

Figure 5.8 – TEST POSITIONS

5.9 WELDING PROCEDURE

The welding procedure shall comply in all respects with the Procedure specification.

5.10 TEST SPECIMENS — NUMBER, TYPE AND PREPARATION

Two (2) test welds shall be made for each procedure and position. For each type of test weld, one shall be made with a 3/16" (5 mm) fillet weld and one shall be made with a 1/8" (3 mm) fillet weld.

5.11 TEST RESULTS REQUIRED

5.11.1 All welds shall be visually inspected and shall be considered acceptable if the inspection shows that:

5.11.1.1 The weld has no cracks.

5.11.1.2 Thorough fusion exists between weld metal and base metal.

5.11.1.3 All craters are filled to the full cross section of the weld.

5.11.1.4 Weld profiles are in accordance with 3.6.

5.11.1.5 The frequency of piping porosity in fillet welds does not exceed one in each 4" (100 mm) of length and the maximum diameter does not exceed 3/32" (2 mm).

5.11.1.6 Fillet welds in any single continuous weld shall be permitted to underrun the nominal fillet size specified by 25% without correction, provided the undersize weld does not exceed 10% of the length of the weld.

5.12 RECORDS

Records of the test results shall be kept by the grating fabricator and shall be available to those authorized to examine them.

5.13 RETESTS

If any one test specimen fails to meet the test requirements and all others pass, two retests for that particular type of test specimen shall be performed with specimens cut from the same procedure qualification test material. The results of both retest specimens shall meet the test requirements.

PART III — WELDER, WELDING OPERATOR AND TACKER

5.14 GENERAL

The qualification for Welders, Welding Operators, and Tackers ability to produce sound welds shall be the same as Part II Procedure Qualification.

5.15 PERIOD OF EFFECTIVENESS

The qualification of Welders, Welding Operators, and Tackers shall be considered as remaining in effect indefinitely unless (1) the person is not engaged in the given process of welding for which they are qualified for a period exceeding 6 months; or unless (2) there is some specific reason to question his ability.

PART IV — QUALIFICATION FORMS

The following forms are offered as examples of Qualification Reports. Other formats may be used if the contents cover the pertinent parts of this standard for steel, aluminum and stainless steel grating.

WELDING PROCEDURE SPECIFICATION										WPS NO.: _____			
										DATE: _____ Rev.: _____			
Company Name: _____						Ref. Standards: _____							
Address: _____						Ref. WPS: _____							
Welding Processes:		1 _____ Pulsed: <input type="checkbox"/> Yes <input type="checkbox"/> No				2 _____ Pulsed: <input type="checkbox"/> Yes <input type="checkbox"/> No							
Shielding Gas Type:													
Positions:						Joint Configuration & Pass/Layer Sequence							
Process Mode: <input type="checkbox"/> Manual <input type="checkbox"/> Semi-Auto <input type="checkbox"/> Machine <input type="checkbox"/> Auto													
Joint Type: <input type="checkbox"/> Butt <input type="checkbox"/> Tee <input type="checkbox"/> Corner <input type="checkbox"/> Lap <input type="checkbox"/> Edge													
Penetration: <input type="checkbox"/> Complete <input type="checkbox"/> Partial ETT= _____ <input type="checkbox"/> Fillet													
Backing: Material: _____ Thickness: _____													
Backgouging: <input type="checkbox"/> Yes Method: _____													
<input type="checkbox"/> No Depth: _____													
Electrode Extension: _____													
Nozzle Diameter(s): _____													
Flux Classification: _____													
Tungsten Electrode: Type: _____ Dia.: _____													
Cleaning Procedures _____													
Identification of Base Material (indicate carbon equivalent, max. phosphorus & sulphur content)													
Part		Specification & Grade				Thickness or Dia.			Special Requirements				
I													
II													
Identification of Filler Material													
Process		Trade Name			Classification			Group		Filler Treatment			
Welding Parameters													
Thick-ness ()	Weld Size/ ETT	Layer	Pass Number	Welding Process	Dia. ()	Wire Feed Speed ()	Current A	Volt V	Current Polarity	Welding Speed ()	Burn-Off Rate ()	Gas Flow Rate	Heat Input ()
Heat treatment :				Acceptance				Company Authorization					
Preheat min:				Interpasstemp.max									
				Interpasstemp.min.:									
Remarks:													
								Date: _____					

PROCEDURE QUALIFICATION RECORD										PQR NO.: _____			
Procedure Qualification <input type="checkbox"/>					Procedure Verification <input type="checkbox"/>					DATE: _____ Rev.: _____			
Company Name: _____					SUPPORTING WPS: _____					Ref. Standards: _____			
Address: _____										Ref. WPS: _____			
Welding Processes:		1			Pulsed: <input type="checkbox"/> Yes <input type="checkbox"/> No			2		Pulsed: <input type="checkbox"/> Yes <input type="checkbox"/> No			
Shielding Gas Type:													
Positions:										Joint Configuration & Pass/Layer Sequence			
Process Mode:		<input type="checkbox"/> Manual <input type="checkbox"/> Semi-Auto <input type="checkbox"/> Machine <input type="checkbox"/> Auto											
Joint Type:		<input type="checkbox"/> Butt <input type="checkbox"/> Tee <input type="checkbox"/> Corner <input type="checkbox"/> Lap <input type="checkbox"/> Edge											
Penetration:		<input type="checkbox"/> Complete <input type="checkbox"/> Partial ETT= _____ <input type="checkbox"/> Fillet											
Backing:		Material: _____			Thickness: _____								
Backgouging:		<input type="checkbox"/> Yes Method: _____ <input type="checkbox"/> No Depth: _____											
Electrode Extension:													
Nozzle Diameter(s):													
Flux Classification:													
Tungsten Electrode:		Type: _____			Dia.: _____								
Cleaning Procedures													
Identification of Base Material (indicate carbon equivalent, max. phosphorus & sulphur content)													
Part	Specification & Grade						Thickness or Dia.			Special Requirements			
I													
II													
Identification of Filler Material													
Process	Trade Name			Classification			Group	Filler Treatment					
Welding Parameters													
Thick-ness ()	Weld Size/ ETT	Layer	Pass Number	Welding Process	Dia. ()	Wire Feed Speed ()	Current A	Volt V	Current Polarity	Welding Speed ()	Burn-Off Rate ()	Gas Flow Rate ()	Heat Input ()
Heat treatment :								Acceptance			Company Authorization		
Preheat min:				Interpasstemp.max.:									
				Interpasstemp.min.:									
Remarks:													
											Date: _____		

WELDERS NAME: _____ ID No: _____

TEST CONDUCTED BY: _____ LAB TEST No: _____

We the undersigned certify that the statements in the record are correct and that the test welds were prepared, welded, and tested in accordance with the requirements of AWS D18.3

MANUFACTURER OR CONTRACTOR: _____

DATE: _____ BY: _____ SIGNATURE: _____

PROCEDURE QUALIFICATION RECORD										PQR NO.:		DATE:		Rev.:	
Procedure Qualification <input type="checkbox"/>					Procedure Verification <input type="checkbox"/>					SUPPORTING WPS: _____					
Company Name: _____							Ref. Standards: _____								
Address: _____							Ref. WPS: _____								
Welding Processes:		1			Pulsed: <input type="checkbox"/> Yes <input type="checkbox"/> No			2		Pulsed: <input type="checkbox"/> Yes <input type="checkbox"/> No					
Shielding Gas Type:															
Positions:							Joint Configuration & Pass/Layer Sequence								
Process Mode:		<input type="checkbox"/> Manual <input type="checkbox"/> Semi-Auto <input type="checkbox"/> Machine <input type="checkbox"/> Auto													
Joint Type:		<input type="checkbox"/> Butt <input type="checkbox"/> Tee <input type="checkbox"/> Corner <input type="checkbox"/> Lap <input type="checkbox"/> Edge													
Penetration:		<input type="checkbox"/> Complete <input type="checkbox"/> Partial ETT= _____ <input type="checkbox"/> Fillet													
Backing:		Material: _____			Thickness: _____										
Backgouging:		<input type="checkbox"/> Yes Method: _____ <input type="checkbox"/> No Depth: _____													
Electrode Extension:															
Nozzle Diameter(s):															
Flux Classification:															
Tungsten Electrode:		Type: _____			Dia.: _____										
Cleaning Procedures															
Identification of Base Material (indicate carbon equivalent, max. phosphorus & sulphur content)															
Part	Specification & Grade						Thickness or Dia.			Special Requirements					
I															
II															
Identification of Filler Material															
Process		Trade Name				Classification				Group		Filler Treatment			
Welding Parameters															
Thick-ness ()	Weld Size/ETT	Layer	Pass Number	Welding Process	Dia. ()	Wire Feed Speed ()	Current A	Volt V	Current Polarity	Welding Speed ()	Burn-Off Rate ()	Gas Flow Rate	Heat Input ()		
Heat treatment :					Acceptance					Company Authorization					
Preheat min:					Interpasstemp.max										
					Interpasstemp.min.:										
Remarks:															
										Date: _____					

WELDERS NAME: _____

ID No: _____

TEST CONDUCTED BY: _____

LAB TEST No: _____

We the undersigned certify that the statements in the record are correct and that the test welds were prepared, welded, and tested in accordance with the requirements of AWS D18.3

MANUFACTURER OR CONTRACTOR: _____

DATE: _____

BY: _____

SIGNATURE: _____