



# HEAVY DUTY METAL BAR GRATING MANUAL

SIXTH EDITION



- **Maximum Bearing Bar Depth . . . . .5" (127 mm)**
- **Bearing Bar Thickness**
  - Maximum . . . . . 3/8" (9.5 mm)**
  - Minimum . . . . . 1/4" (6.4 mm)**

Approval of an American National Standard requires verification by ANSI that the requirements for due process, consensus, and other criteria for approval have been met by the standards developer.

Consensus is established when, in the judgment of the ANSI Board of Standards Review, substantial agreement has been reached by directly and materially affected interests. Substantial agreement means much more than a simple majority, but not necessarily unanimity. Consensus requires that all views and objections be considered, and that a concerted effort be made toward their resolution.

The use of American National Standards is completely voluntary; their existence does not in any respect preclude anyone, whether he has approved the standards or not, from manufacturing, marketing, purchasing, or using products, processes, or procedures not conforming to the standards.

The American National Standards Institute does not develop standards and will in no circumstances give an interpretation of any American National Standard. Moreover, no person shall have the right or authority to issue an interpretation of an American National Standard in the name of the American National Standards Institute. Requests for interpretation should be addressed to the sponsor whose name appears on the title page of this standard.

**CAUTION NOTICE:** This American National Standard may be revised or withdrawn at any time. The procedures of the American National Standards Institute require that action be taken periodically to reaffirm, revise, or withdraw this standard. Purchasers of American National Standards may receive current information on all standards by calling or writing the American National Standards Institute.

This standard was developed by representative members of the Metal Bar Grating Division (MBG) of the National Association of Architectural Metal Manufacturers (NAAMM) to provide their opinion and guidance on the specification and use of metal bar gratings. This standard contains advisory information only and is published as a public service by NAAMM. NAAMM and its Divisions disclaim all liability of any kind for the use, application, or adaptation of material published in this standard.

Current information on all NAAMM Standards is available by calling or writing the National Association of Architectural Metal Manufacturers or by going to [www.naamm.org](http://www.naamm.org).

**National Association of Architectural Metal Manufacturers**  
800 Roosevelt Road  
Bldg. C, Suite 312  
Glen Ellyn, Illinois 60137  
Phone: (630) 942-6591 Fax: (630) 790-3095  
[www.naamm.org](http://www.naamm.org)

Copyright © 1986, 1988, 1995, 2000, 2009, 2018  
**National Association of Architectural Metal Manufacturers**  
All Rights Reserved

# METAL BAR GRATING MANUAL

*For Heavy Duty Steel, and Stainless Steel Gratings*

Sixth Edition

NAAMM MBG 532

Published and distributed by the

**NATIONAL ASSOCIATION OF ARCHITECTURAL METAL MANUFACTURERS**

800 Roosevelt Road  
Bldg. C, Suite 312  
Glen Ellyn, Illinois 60137  
Phone: (630) 942-6591  
[www.naamm.org](http://www.naamm.org)  
email: [info@naamm.org](mailto:info@naamm.org)

## **NAAMM'S METAL BAR GRATING DIVISION**

The members of the Metal Bar Grating Division of the National Association of Architectural Metal Manufacturers have supported the preparation of this Manual. All are producers and/or suppliers of products conforming to the standards and specifications contained herein. A copy of the Membership Roster of the Metal Bar Grating Division is available from NAAMM at [www.naamm.org](http://www.naamm.org).



## FOREWORD

The NAAMM Heavy Duty Metal Bar Grating Manual provides architects and engineers with current technical data on heavy duty bar gratings of structural carbon steel and stainless steel. The data includes descriptions of the most frequently used types of gratings, the methods used in their fabrication, dimensional standards, load tables giving allowable uniform and concentrated loads for spans from one foot (305 mm) through eight feet (2440 mm), installation practices, specifications, code of standard practice and glossary. The information is concerned primarily with bar gratings capable of supporting heavy loads. Architects and engineers interested in lighter walkway gratings are referred to the current edition of NAAMM's Metal Bar Grating Manual (ANSI/NAAMM MBG 531).

The first five editions of the manual have been widely used by the design professions. In preparing this sixth edition, the Metal Bar Grating Division of NAAMM has reviewed its contents in detail and has made revisions to reflect current practices. NAAMM believes that the scope of this manual makes it an excellent reference source for those concerned with the design of structures incorporating heavy duty metal bar gratings.

The load tables in this edition are based on the design formulas and procedures found in ANSI/NAAMM MBG 534, Metal Bar Grating Engineering Design Manual, which was developed to provide a clearer understanding of the procedures used in the design of grating.

Also included are metric equivalents as an aid to designers who must use the metric system. The system of metric measurement used is from IEEE/ASTM SI 10-2016, "Standard for Use of the International System of Units (SI): the Modern Metric System". **The values stated in inch-pound units are to be regarded as the standard.**

This manual presents the common heavy duty gratings manufactured by NAAMM members. NAAMM recognizes the many special designs that embody the use of special steel shapes and/or larger structural members that are used under the same conditions. Because these designs are so varied, they are not covered in this publication but can be manufactured according to the principles within this manual. Consult the manufacturers of these specialty items for technical information.

Changes from the prior version, ANSI/NAAMM MBG 532-09 are indicated by the placement of a vertical line next to the changed item.

---

## CONTENTS

<b>Introduction.....</b>	<b>3</b>
<b>Some Typical Uses of Gratings .....</b>	<b>3</b>
<b>Standard Marking System .....</b>	<b>4</b>
<b>Standard Gratings .....</b>	<b>6</b>
<b>Cross Bars and Reticuline Bars .....</b>	<b>7</b>
<b>Anchoring Details .....</b>	<b>8</b>
<b>Installation Notes and Panel Dimensions .....</b>	<b>9</b>
<b>Installation Clearances .....</b>	<b>10</b>
<b>Manufacturing Tolerance .....</b>	<b>11</b>
<b>Operating and Maintenance Instructions .....</b>	<b>12</b>
<b>Welding Toe Plate and Banding .....</b>	<b>13</b>
<b>Ordering Information.....</b>	<b>14</b>
<b>Specifications .....</b>	<b>15</b>
<b>Code of Practice.....</b>	<b>16</b>
<b>Load Tables for Welding and Riveted Heavy Duty Carbon Steel Gratings.....</b>	<b>20</b>
<b>Glossary of Terms.....</b>	<b>67</b>

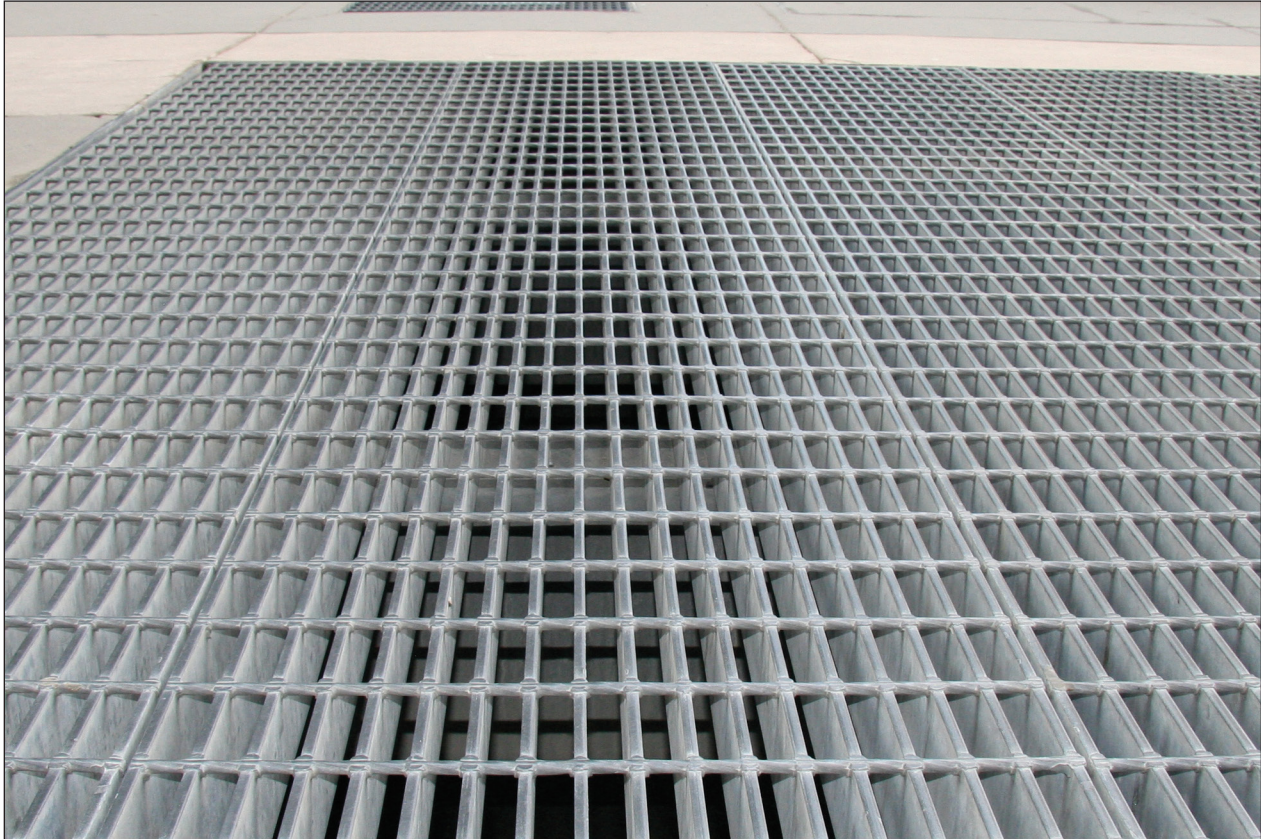



## INTRODUCTION

Metal bar gratings, simply defined, are open grid assemblies of metal bars in which the principal load bearing bars run parallel in one direction and are spaced equidistant from each other, either by rigid attachment to cross bars running in a perpendicular direction, or by attachment to reticuline bars extending between them.

There are three types of steel bar gratings – welded, pressure-locked, and riveted. Welded gratings are fabricated by joining bearing bars and cross bars at their intersections by welding. In pressure-locked gratings the cross bars are mechanically locked to the bearing bars by deforming the bars under tremendous hydraulic pressure. For riveted gratings the reticuline bars are joined to the bearing bars at their points of contact by riveting.

Metal bar gratings of all three types provide economical structures with high strength-to-weight ratios for use in many applications, a number of which are listed below. Relatively unrestricted passage of water, light, air, and heat are some of the features which make gratings not only desirable but essential in certain types of construction. Floor gratings permit immediate drainage of water from rain or other sources. They also simplify the ventilation and heating of certain types of industrial buildings.

Floor gratings are capable of supporting both pedestrian and vehicular traffic. Lighter weight gratings are satisfactory for pedestrian traffic; but, where heavy loads, including vehicular traffic, are involved, heavy duty metal bar gratings must be used. Heavy vehicular traffic is encountered in industrial plants with their heavy load carrying lift trucks and on highways and bridges with heavy trucks and tractor-trailers. The metal bar gratings described in this manual are used for these heavy duty applications. The load tables presented are based upon allowable stresses for static loads supplemented by vehicular load tables based upon specific design criteria. The effects of impact and alternative design criteria shall be considered when designing metal bar grating for vehicular traffic.

Metal bar grating for bridge decking has some very specific advantages. Because of its light weight and simple installation, as compared with other surfaces, it permits resurfacing to handle heavier loads without the need for expensive sub-structure work. An additional advantage is that a municipality can carry a stock inventory of grating and replace a bridge surface quickly and economically.

Different applications impose different requirements on gratings. It is important, therefore, that the architect or engineer consult with the manufacturer in the selection of heavy duty metal bar gratings. The members of NAAMM who fabricate such gratings have many years of experience with many types of uses all over the country.

## SOME TYPICAL USES FOR GRATINGS

Airplane Landing Mats	Flooring	Pressure Vessel Internal Trays
Airplane Unloading Ramps	Fork Lift Traffic	Racks and Shelving
Animal Fences	Freight Car Flooring	Railway Crossings
Areaways	Highway Traffic	Ramps
Bar Screens	Hoppers	Stacked Parking Areas
Boat Landing Ramps	Machine and Motor Bases	Stage Supports
Bridge Centerline Markers	Machinery Safety Guards	Trap Doors
Bridge Flooring	Machinery Support Trenches	Trash Racks
Bridge Sidewalks	Material Screens	Trench Covers
Cattle Guards	Mezzanine Floors	Truck Beds
Concrete Armoring	Missile Protection	Vault Covers
Concrete Reinforcement	Mooring Docks	Vehicular Traffic Support
Drainage Pit Covers	Parapet Screens	Wash Racks
Floor Boards	Partitions	Window Guards
	Platforms	

## STANDARD MARKING SYSTEM

The marking system described here is the industry standard for identifying various types of bar grating. Leading manufacturers shall correlate their individual marking systems with this standard.

The standard marking system for metal bar grating, as illustrated on the facing page, identifies five characteristics of the grating in the following order:

### 1 TYPE OF GRATING

The type of grating shall be indicated by a letter, as follows:

- W Welded
- P Pressure-locked
- R Riveted

(See Glossary for definitions of types)

### 2 BEARING BAR SPACING

Bearing bar spacing shall be designated by a number which indicates sixteenths of an inch, or mm.

For welded or pressure-locked grating this is the distance, in sixteenths of an inch, or mm **center-to-center** of bars.

For riveted grating it is the distance, sixteenths of an inch, or mm **between bearing bar faces**.

### 3 CROSS BAR OR RIVET SPACING

Cross bar or rivet spacing shall be designated by a number which indicates inches, or mm.

For welded or pressure-locked grating this is the distance, in inches or mm, center-to-center of cross bars. For riveted grating it is the distance in inches or mm center-to-center of rivets, measured along a single bearing bar.

In addition to spacings covered in this manual, consult individual manufacturers for other spacings available.

### 4 SIZE OF BEARING BARS

**(COVERED IN THIS MANUAL)\***

The size of bearing bars shall be expressed in inches or mm of depth and thickness as follows.

\*Equivalent bearing bar sizes in millimeters are obtained by a multiplication factor of 25.4.

1 x 1/4	1-1/4 x 1/4	1-1/2 x 1/4	1-3/4 x 1/4
1 x 3/8	1-1/4 x 3/8	1-1/2 x 3/8	1-3/4 x 3/8
2 x 1/4	2-1/4 x 1/4	2-1/2 x 1/4	3 x 1/4
2 x 3/8	2-1/4 x 3/8	2-1/2 x 3/8	3 x 3/8
3-1/2 x 1/4	4 x 1/4	4-1/2 x 1/4	5 x 1/4
3-1/2 x 3/8	4 x 3/8	4-1/2 x 3/8	5 x 3/8

Note: The use of bearing bars larger than 5 x 3/8 is not addressed in this manual.

### 5 MATERIAL

Grating material shall be designated by name, such as "steel" or "stainless steel."

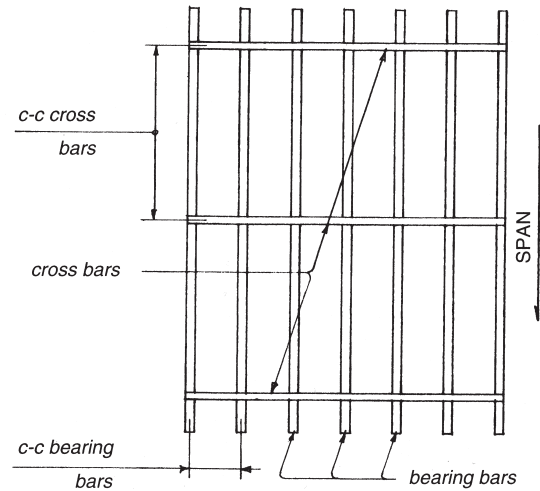

WELDED OR  
PRESSURE-LOCKED GRATING

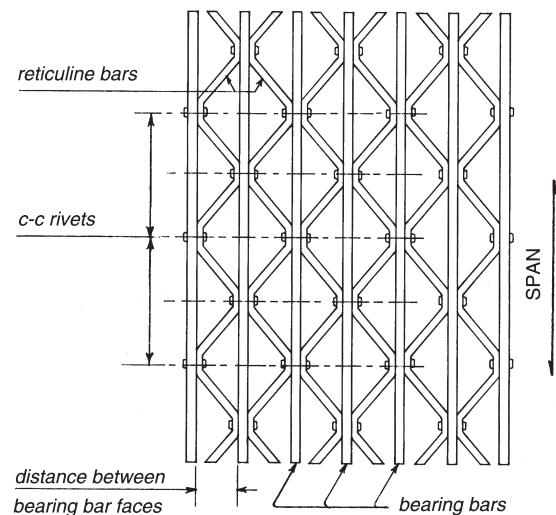

RIVETED GRATING

**EXAMPLES OF  
USE OF STANDARD  
MARKING SYSTEM**

**TYPE****DESCRIPTION OF GRATING DESIGNATED**

**W-22-4 (3 X 1/4) STEEL**  
(W-35-102)

W welded  
22 bearing bars spaced 1<sup>3</sup>/<sub>8</sub> in. (35 mm) on center  
4 cross bars spaced 4 in. (102 mm) on center  
(3 x 1/4) bearing bar size, 3 in. x 1/4 in. (76 mm x 6.4 mm)  
STEEL material

**P-38-4 (4 X 3/8) STAINLESS  
(P-60-102) STEEL**

P pressure-locked  
38 bearing bars spaced 2<sup>3</sup>/<sub>8</sub> in. (60 mm) on center  
4 cross bars spaced 4 in. (102 mm) on center  
(4 x 3/8) bearing bar size, 4 in. x 3/8 in. (102 mm x 9.5 mm)  
STAINLESS material  
STEEL

**R-37-5 (3 X 1/4) STEEL**  
(R-59-127)

R riveted  
37 bearing bars spaced 2<sup>5</sup>/<sub>16</sub> in. (59 mm) between faces  
5 rivets spaced 5 in. (127mm) on center  
(3 x 1/4) bearing bar size, 3 in. x 1/4 in. (76 mm x 6.4 mm)  
STEEL material

**Manufactures are equipped to produce gratings having bearing bars and cross bars of other sizes and spacings than shown in this manual. Minimum and maximum sizes and spacings are determined by equipment and / or design factors.**

**While gratings are normally furnished with a finish as indicated in section V of the Standard Specifications Section, a wide variety of non-standard finishes can be applied to address specific job and / or function requirements.**

**Individual manufactures should be consulted regarding all non-standard products and / or finishes.**

**STANDARD  
GRATINGS**

See GLOSSARY OF TERMS for definitions of *Welded, Pressure-locked, and Riveted Gratings*

**WELDED  
TYPE W-22-4  
(W-35-102)**

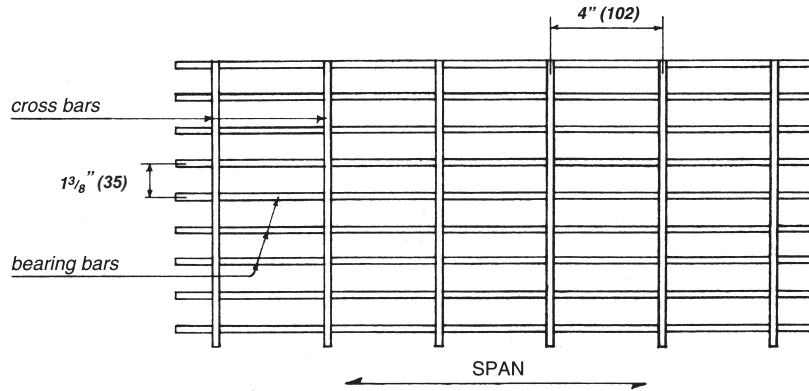

**PRESSURE-LOCKED  
TYPE P-38-4  
(P-60-102)**

Pressure-locked grating cross bars shall be welded to the first and last bearing bars.

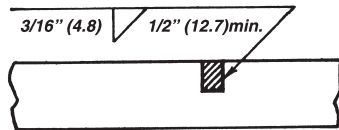
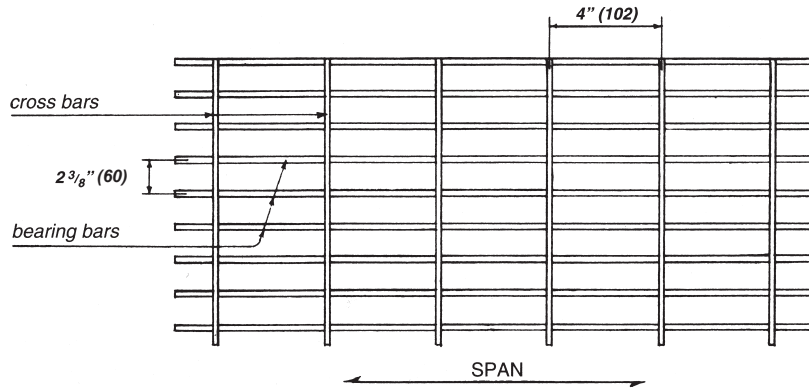

**RIVETED  
TYPE R-37-5  
(R-59-127)**

Furnish riveted grating with either straight or crimped reticuline bars.

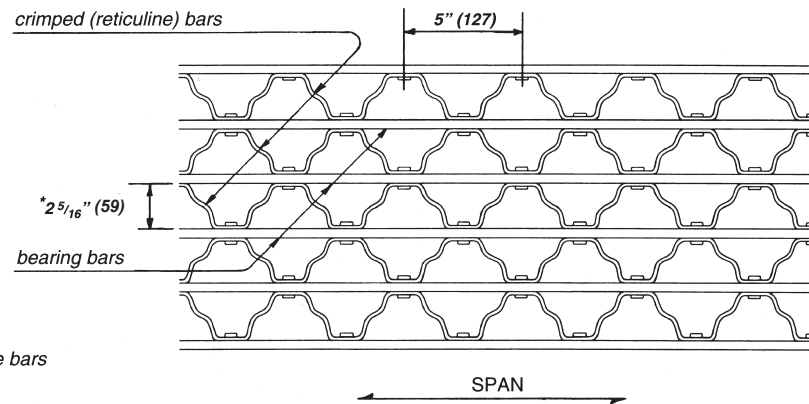
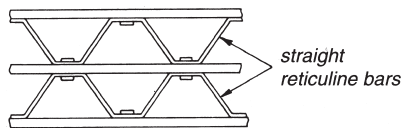

**\*Note that riveted grating marking indicates space between bearing bars**

**CROSS BARS AND  
RETICULINE BARS****MINIMUM STANDARD SIZES****CROSS BARS AND RETICULINE BARS**

All cross bars and reticuline bars shall be sized in accordance with this section. The minimum size of cross bars and reticuline bars shall be based on the type of grating system and the size of bearing bar used. Cross bars used in W type grating systems shall comply with the minimum sizes given in Table No.1. Cross bars used in P type grating systems shall comply with the minimum sizes given in Table No. 2. Reticuline bars used in R type grating systems shall comply with Table No. 3.

**Table No. 1—WELDED — (W)\***

Bearing Bars			Cross Bars	
Thickness	Depth	Center to Center	Minimum Cross Sectional Area	Weight
in. (mm)	in. (mm)	in. (mm)	in. <sup>2</sup> (mm <sup>2</sup> )	lb./ft. (kg/m)
1/4 (6.4)	5 (127) or less	all spacings	0.062 (40)	.211 (.314)
3/8 (9.5)	1 1/4 (32) or less	all spacings	0.062 (40)	.211 (.314)
3/8 (9.5)	more than 1 1/4 (32)	all spacings	0.085 (55)	.290 (.432)

\*Minimum size shown is for cross bars on 4 inch centers.

When cross bars are on 2 inch centers, the minimum size may be reduced by 25%.

**Table No. 2—PRESSURE-LOCKED — (P)**

Bearing Bars			Cross Bars
Thickness	Depth	Center to Center	Minimum Size
in. (mm)	in. (mm)	in. (mm)	in. (mm)
1/4 (6.4)	1 1/4 (32) or less	all spacings	3/4 x 3/16 (19 x 4.8)
1/4 (6.4)	1 1/2 (38) thru 2 1/4 (57)	all spacings	1 x 3/16 (25 x 4.8)
1/4 (6.4)	more than 2 1/4 (57)	all spacings	1 1/4 x 3/16 (32 x 4.8)
3/8 (9.5)	1 1/2 (38) thru 2 1/4 (57)	all spacings	3/4 x 1/4 (19 x 6.4)
3/8 (9.5)	more than 2 1/4 (57)	all spacings	1 x 1/4 (25 x 6.4)

Cross bars and reticuline bars shall provide the spacing and bracing for the bearing bars and are essential for the stabilization of the grating and the effective distribution of the load across the grating. The satisfactory performance of the grating is dependent on the integrity of the welded, pressure-locked or riveted joints and the use of cross bars or reticuline bars of a size adequate to perform their function.

**Table No. 3—RIVETED — (R)**

Bearing Bars	Reticuline Bars	Rivets
Depth	Minimum Size	Minimum Diameter
in. (mm)	in. (mm)	in. (mm)
2 (51) thru 5 (127)	1 1/2 x 3/16 (38 x 4.8)	3/8 (9.5)

**HEAVY DUTY WELDED GRATING**



## ANCHORING DETAILS

All gratings are to be firmly anchored to their supports by positive means.

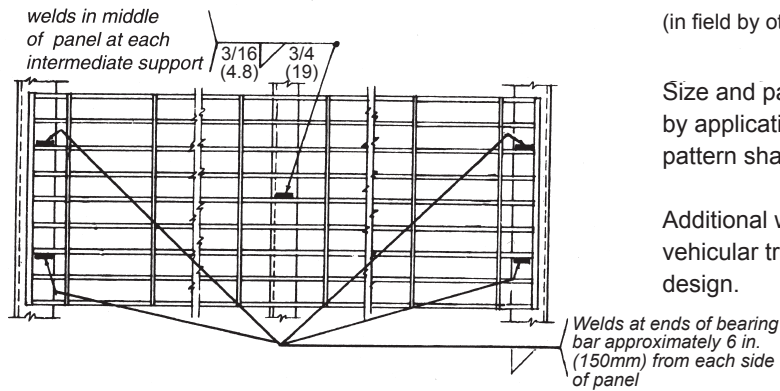

### 1 WELDED ANCHORAGE

(in field by others)

Size and pattern of welds shall be determined by application and/or size of grating. Minimum pattern shall be as shown.

Additional welding to supports required for vehicular traffic shall be specified by the design.

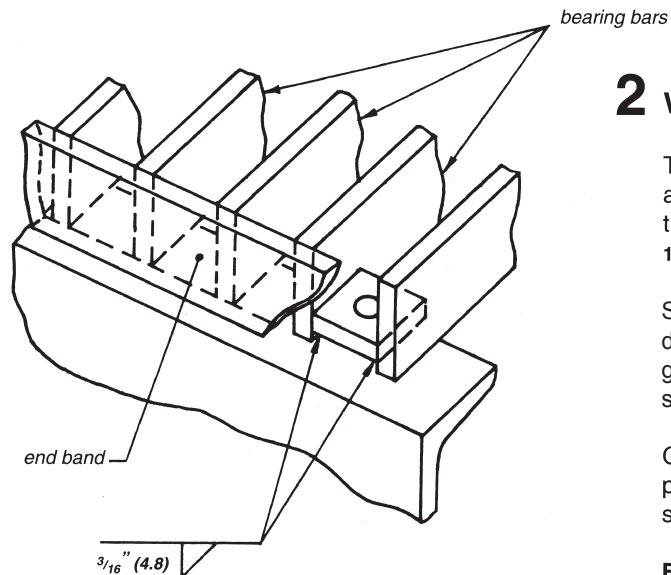

### 2 WELD LUGS

The designer shall specify when weld lugs are to be provided by the grating manufacturer. When provided, weld lugs shall be 1/4 in. (6.4 mm) minimum thickness.

Size and pattern of bolts or studs shall be determined by application and / or size of grating. Minimum pattern shall be as shown in welded anchorage (above).

Grating panels shall be used as a template by installing activity to locate holes or studs on structural supports.

**Bolts, studs and miscellaneous hardware are not supplied by the grating manufacturer.**



## INSTALLATION NOTES PANEL DIMENSIONS

### GENERAL REQUIREMENTS FOR GRATING INSTALLATION

1. Unpack grating and inspect for damage.
2. Grating shall be installed with cross bars on top.
3. Preliminarily install all grating into area per layout drawing.
4. Adjust spacing between panels to allow for proper pack out and equal spacing between panels and between supports.
5. Verify that all grating is adequately supported. Notching bearing bars at supports or interrupting bearing bars with cutouts shall only occur when the system has been designed for such modification and is specified by the design engineer and indicated on the plans.
6. Securely fasten all grating as specified for project or per NAAMM recommendations.

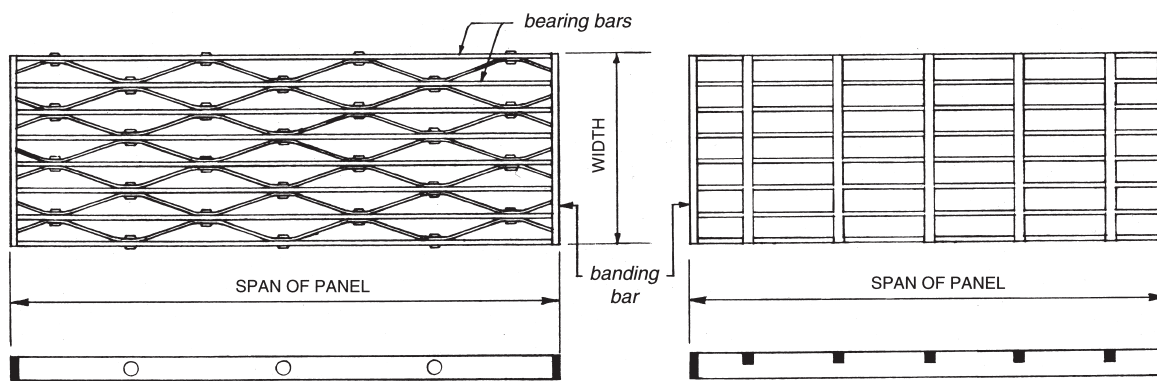

SPAN of panel is measured parallel to the bearing bars.

WIDTH of panel is measured perpendicular to the bearing bars, even if this dimension exceeds the panel span.

### SUPPORT and BANDING of TRENCH GRATING

Each end of a metal bar grating panel installed in a trench shall be supported on an angle or other shape whose inside vertical dimension equals that of the bearing bar.

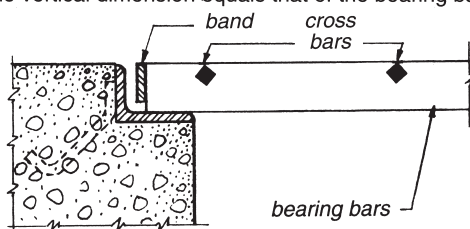

Specify load banding on all gratings subject to rolling loads. Full depth band is supplied by manufacturer for all banded grating unless owner or specifier states clearly that shallow banding shall be provided.

For trench grating, banding bar shall be 1/4 in. (6.4 mm) to 1/2 in. (12.7 mm) less than depth of grating to permit drainage.



HEAVY DUTY WELDED GRATING

**STANDARD  
INSTALLATION CLEARANCES**

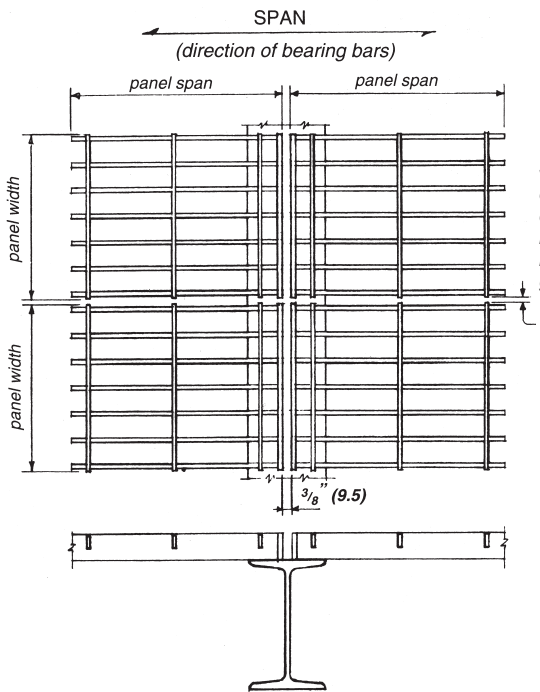

*3/8" (9.5) nominal clearance between ends of cross bars on rectangular grating or rivet heads on riveted grating.*

Metal shall be used for all grating supports and provide a 1 in. (25 mm) minimum bearing surface for depths up to 2 1/4 in. (57 mm), and 2 in. (51 mm) minimum bearing surface for depth 2 1/2 in. (64 mm) and over, at each end of span.

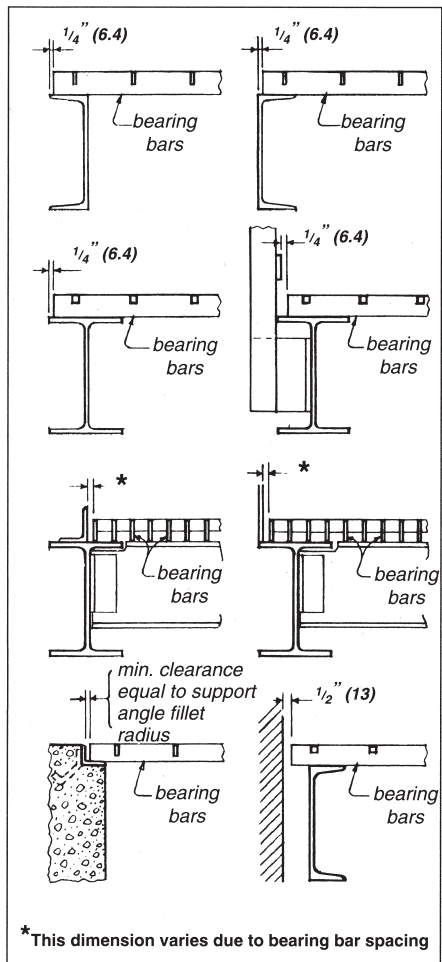

Clearances shall be as shown, but shall be permitted to vary in accordance with dimensional tolerances shown on page 11.

Heavy duty grating shall be designed to have structural support under each bearing bar at cut-outs.



All dimensions given are maximum permissible tolerances  
 SPAN indicates the length of the grating in the direction of the bearing bars.

**MANUFACTURING TOLERANCES**

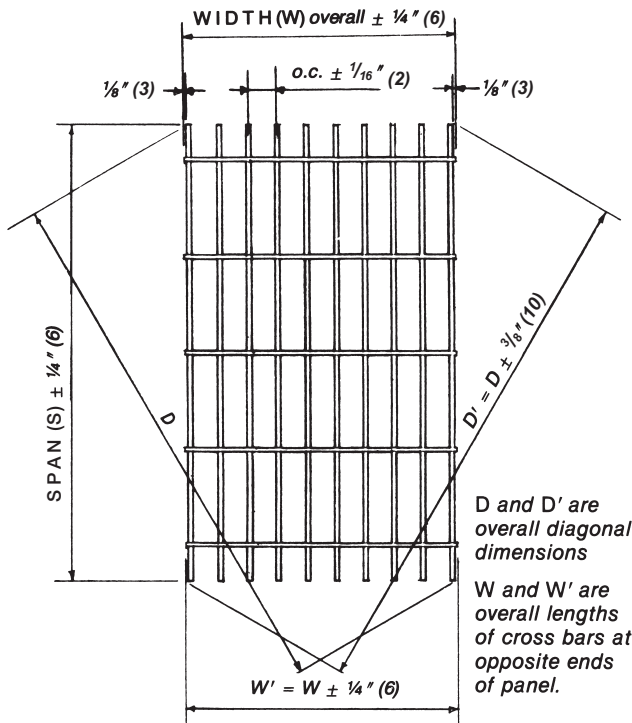

**overall dimensions and squareness**  
 Sweep 1/200 of Span

Cross bar shall not vary more than  $\frac{1}{8}$  in 12 in either direction from perpendicular alignment with bearing bars.

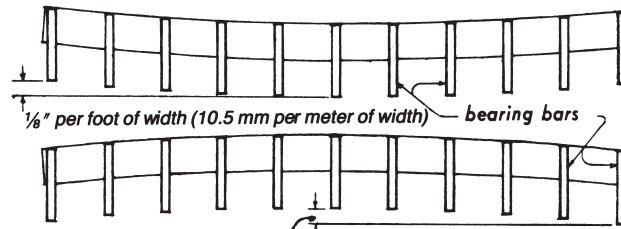
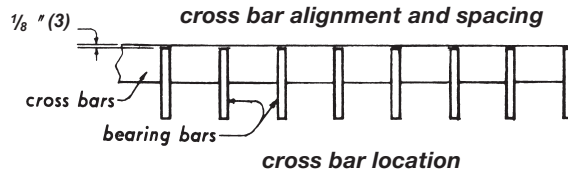
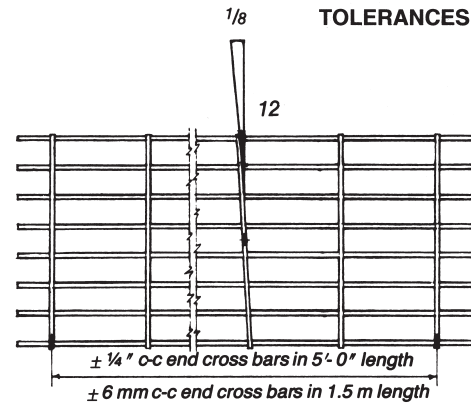

$\frac{1}{8}''$  per foot of width (10.5 mm per meter of width)  
**transvers bow**  
 (before fastening to supports)

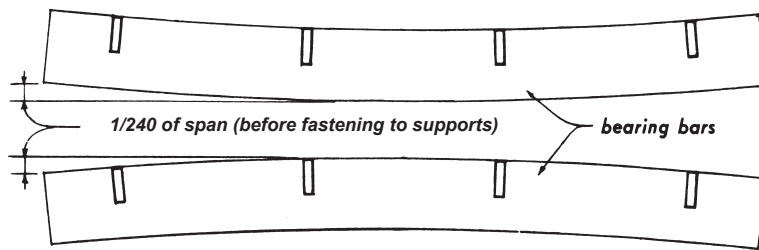
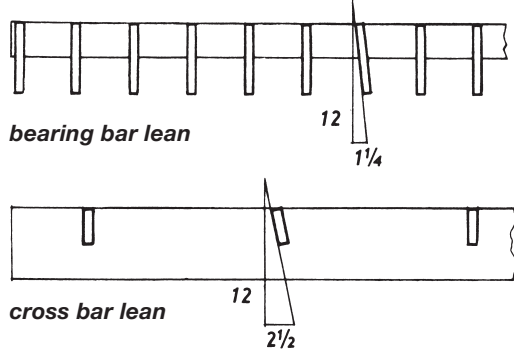

**longitudinal bow**

## OPERATION AND MAINTENANCE INSTRUCTIONS

1. For pedestrian load rated grating design, grating is intended for normal walking pedestrian traffic. Precautions shall be taken to prevent wheel or other loads beyond the design load rating for the application.
2. For other uniform or concentrated load rating applications, precautions shall be taken to prevent loads beyond the design load rating for the application.
3. Periodically inspect grating for damage or excessive wear, such as corrosion, damage to the finish, deformation and excessive bearing bar lean beyond the tolerances as noted on page 11. Repair or replace any areas showing damage.
4. Periodically inspect grating to be sure that all grating is securely fastened as specified for the application or as noted on page 8, if fastening method is not specified. Replace any missing attachment hardware and tighten any loose connections.

**WELDING OF  
TOE PLATES AND BANDING**

The welding standards shown here apply to those gratings and treads having a clear opening of not less than 5/8 in. (16 mm) between bearing bars and those galvanized as per Specifications, page 15. See ANSI/NAAMM MBG 533 "Welding Specifications for Fabrication of Steel, Aluminum and Stainless Steel Bar Grating" for welding specifications and certification of welders.

**TOE PLATES**

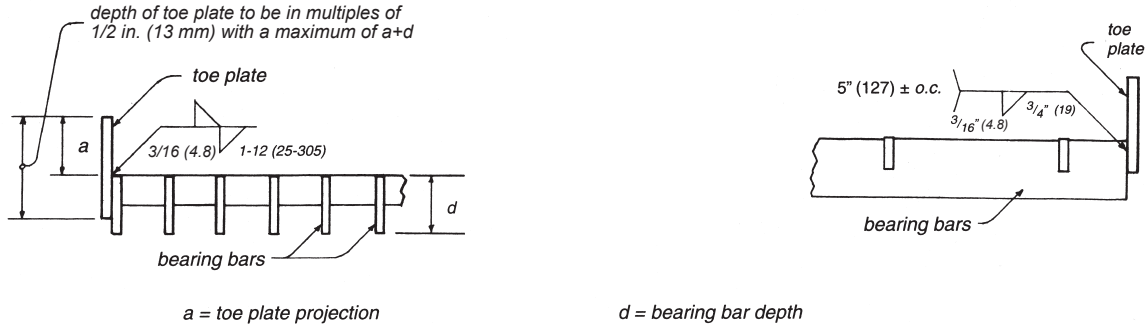

**BANDING**

Minimum thickness = 1/4 in. (6 mm)  
For standard banding, band bar shall be same depth as bearing bars.

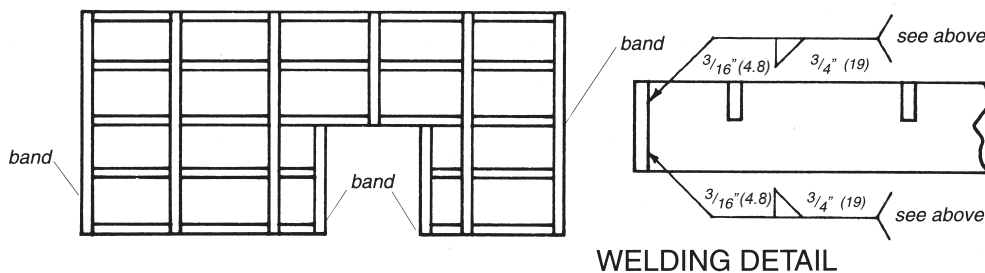
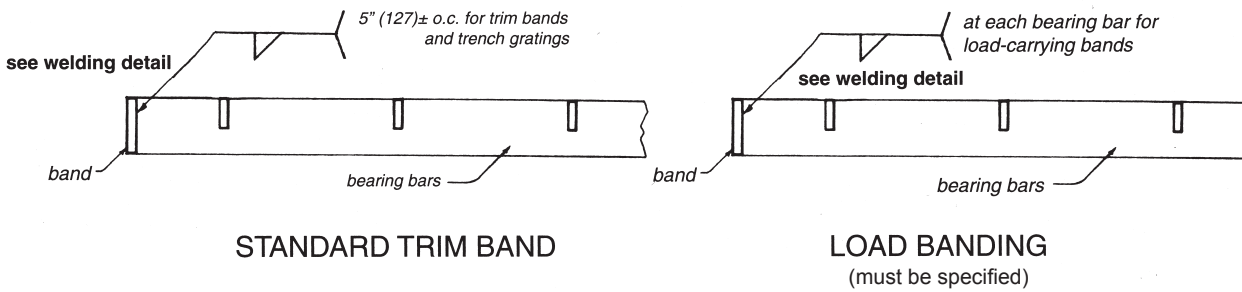

For depth less than 2-1/2 in. (64 mm), weld one side at top.

For depth 2-1/2 in. (64 mm) or greater, weld one side at top, opposite side at bottom; or weld exceeding one-half depth on one side only.

Banding heavy duty metal bar gratings at panel ends and cut-outs improves durability while enhancing appearance. By increasing transverse stiffness, banding distributes and absorbs impact at the primary point of contact. Where light vehicular traffic flow is parallel to the bearing bars, standard banding is sufficient. For heavy, high speed or multi-directional traffic, load carrying banding shall be designed for the effects of impact and fatigue. Structural support shall be provided for all cut-outs accessible to vehicular traffic.

**ORDING  
INFORMATION**

**INFORMATION TO BE PROVIDED**  
**when specifying or purchasing METAL BAR GRATING:**

---

**Description of grating** (see standard marking system, page 4 of this Manual)

**A drawing, showing:** area to be covered (including all cutouts)  
span (direction of bearing bars)  
method of support (including locations of weld lugs if specified)  
all critical dimensions  
(indicate whether clearances are taken into account)  
serrated or plain surface

**Type of anchorage :** (see page 8 of this Manual)

**Finish:** Steel gratings—manufacturer’s standard paint or galvanized

**Shipping instructions**

## **REFERENCES**

### **NAAMM STANDARD ANSI/NAAMM MBG 533 - Welding Specifications for Fabrication of Steel, Aluminum and Stainless Steel Bar Grating**

This Standard covers fillet welding requirements as they apply to bar grating but not high stress structural welds. Welder qualification forms are included.

### **NAAMM STANDARD ANSI/NAAMM MBG 534 - Metal Bar Grating Engineering Design Manual**

This Standard was developed to provide a clearer understanding of the procedures used in the design of grating and in the development of load tables.



# STANDARD SPECIFICATIONS

## for Heavy Duty Metal Bar Grating

### I. SCOPE

These specifications apply to heavy duty metal bar grating as hereinafter defined and described.

### II. DEFINITIONS

a) Heavy duty metal bar grating is an open grid of metal bars. The bearing bars, which have a cross-sectional depth not less than two times their width, are held at regular parallel spacing, either by:

1. Straight, sinuous or corrugated cross bars having their longitudinal axis perpendicular to the bearing bar and being connected to them by welding, forging or mechanical locking, or by
2. Reticuline bars alternately contacting adjacent bearing bars and riveted to them at regular intervals.

b) Definitions of other terms shall conform to those given in the Glossary of Terms in the Heavy Duty Bar Grating Manual.

### III. MATERIALS

a) Steel gratings:

Steel used in bearing bars shall have mechanical properties equal to, or greater than the performance of ASTM A1018 GRADE 36 for hot rolled carbon steel coil. Steel used in cross bars and connecting bars of rectangular section shall have mechanical properties equal to, or greater than the performance of ASTM A 1011/A 1011M Commercial steel (Type B) for hot rolled carbon steel sheet and strip.

Cross bars made of wire rod shall conform to ASTM A 510 (A 510M) for carbon steel wire rods and coarse round wire, except that permissible tolerance on diameter of course round wire shall be + or - 0.005 in. (+ or - 0.13 mm). Combinations of these steels are not prohibited from being welded together.

Rivets shall be a steel as prescribed in ASTM A575, 3/8 in. (9.5 mm) minimum diameter, flat head type.

b) Stainless Steel Gratings

Stainless steel used in bearing bars, cross bars and reticuline bars shall be Type 304, 304L, 316, or 316L alloy conforming to ASTM A 666.

Rivets shall be of a Type 300 series alloy as prescribed in ASTM A 493.

### IV. SIZE OF MEMBERS

a) All bearing bars shall be of nominal size as shown in the Load Tables of the Heavy Duty Metal Bar Grating Manual.

b) All materials shall be in accordance with the ASTM A6/A6M tolerances.

c) Banding Bars shall have a minimum thickness of 1/4" (6.4 mm).

### V. FABRICATION

Basic fabrication of welded, riveted and pressure-locked grating shall be as defined in the Glossary of Terms.

a) All tolerances shall be within the limits shown on page 11 of the Heavy Duty Metal Bar Grating Manual.

b) Bandings and toe plates, when specified, shall be attached by welding as shown on page 13 of the Heavy Duty Metal Bar Grating Manual.

c) All cutouts where more than one bearing bar is cut and bearing bars are not supported shall be load banded.

d) Unless specifically ordered otherwise, no welds anywhere on the grating will be ground.

e) Finishes: Carbon steel gratings shall be specified unfinished, galvanized, or painted one coat of manufacturer's standard paint applied in accordance with the manufacturer's standard practice. One coat of manufacturer's standard paint is designed as an economical solution for many applications. Gratings specified to be galvanized shall have their exposed surfaces zinc-coated by the hot dip process per ASTM A 123 after fabrication. Gratings and / or treads stored at the jobsite shall be covered or under roof. **Required covering is not the responsibility of the grating and / or tread supplier.**

Unless otherwise specified, abrasive nosings will have the manufacturer's standard finish.

Aluminum and stainless steel gratings shall have a mill (as fabricated) finish, unless otherwise specified.

### VI. ANCHORAGE

Unless otherwise specified, gratings shall be welded to their supports as specified in accordance with page 8 of the Heavy Duty Metal Bar Grating Manual.

If weld lugs are required they shall be so specified and shall be welded to the grating by the manufacturer where specified in accordance with the provisions for weld lugs on page 8 of the Heavy Duty Metal Bar Grating Manual.

**CODE OF STANDARD PRACTICE****CODE OF STANDARD PRACTICE**

**The following Code represents generally accepted standard practice in the metal bar grating industry. In order to avoid misunderstanding, these practices will apply only to manufacturers individually adopting them, and then, only to the extent each manufacturer has not made unilateral modifications. Each manufacturer is free to modify the Code generally or as it specifically agrees with any Buyer.**

---

**1. GENERAL****1.1 Scope and Application**

The rules and practices contained in this Code were developed by the NAAMM Metal Bar Grating Division as standard for the industry. Unless specifically stated otherwise, they shall be considered applicable to, and a part of, all contracts relating to the purchase and supply of metal bar gratings and/or treads.

No provisions herein contained, however, shall be construed as denying the right of any company to set its own prices and terms of sale, or restricting any Buyer or Seller from voiding, by mutual agreement, any part of this Code.

**1.2 Definitions**

As used in this Code, the term “product” or “products” refers to metal bar gratings or metal bar grating treads, and their accessories; the term “Buyer” to the party, or authorized representative of the party, who contracts to purchase such products, and the term “Seller” to the manufacturer who contracts to supply them.

**1.3 Designs and Materials**

Unless otherwise specified, all designs and materials shall be in accord with the Standard Specifications for Heavy Duty Bar Gratings as published in the ANSI/NAAMM MBG 532 Manual, latest edition, and the ANSI/NAAMM MBG 534 Engineering Design Manual, latest edition.

**2. QUOTATIONS****2.1 Bidding Plans**

Plans intended to serve as the basis for bidding shall provide complete information as to the description of the product, the limits of areas to be covered, the direction of span of grating panels, all supporting members, all cutouts to be provided in the grating area, anchors if required, and finishes desired.

**2.2 Basis of Unit Price Quotations**

Quotations shall preferably be on the basis of unit price per square foot (square meter) of grating and per tread. The quoted grating price shall be for grating furnished in rectangular sections.



**CODE OF STANDARD PRACTICE****2.3 Extras:**

The following are examples of items not included in unit price quotations, and shall be considered as extras in quotations:

Cutting	Degreasing or sandblasting
Banding	Special bundling or strapping other than steel strapping
Toe plates	Field measurements
Support plates or angles	Installation
Hinges	Any materials, practices or finishes not called for in the Standard Specifications for Heavy Duty Metal Bar Gratings includ- ing special welding if galvanized in accord with ASTM A 385.
Locking devices	
Forming, undercutting or notching	
Special drilling, punching or tapping	
Anchors	
Bolts for stair treads	

Research of structural steel detail drawings to determine the cutout dimensions for vertical bracing and moment connections when such details are not furnished prior to start of preparation of grating drawings.

**3. DRAWINGS AND SPECIFICATIONS****3.1 Construction Drawings and Specifications**

The Buyer shall be expected to furnish to the Seller an electronic file of construction drawings and specifications of current issue showing the layout of supports and floor openings correctly dimensioned, together with the sizes and types of grating and treads desired. Should cutouts for vertical bracing or moment connections be required for shop fabrication, the structural steel detail drawings shall be furnished prior to the preparation of the grating drawings.

If construction drawings and specifications are not available, the Buyer shall provide complete information regarding all items listed in "Information to be Provided" as shown on page 12 of the ANSI/NAAMM MBG 532 Heavy Duty Bar Grating Manual.

**3.2 Limit of Seller's Responsibility**

In the absence of written notice to the contrary, the Buyer's construction plans and specifications will be assumed by the Seller to be correct in all details, and the Seller's responsibility shall be limited to furnishing the products in accord with these documents.

**3.3 Approval Drawings**

If required by the Buyer, the Seller shall submit to the Buyer one electronic copy of detailed drawings in outline form for the latter's review. The Buyer shall return one copy marked with his approval or desired changes. Should changes be required which involve work not called for in the original construction plans and specifications, the Seller shall have the right to charge extra for the engineering work required to make such changes. After all necessary corrections and/or changes are made, the drawings shall be re-submitted to the Buyer for his final review. The Seller shall not proceed with any shop work until drawings are approved for fabrication.

**3.4 Installation Drawings**

If requested, the Seller shall furnish to the Buyer an electronic copy of all installation drawings.

**4. QUANTITY MEASUREMENTS**

- 4.1 Quantity measurements for gratings ordered to specific dimensions, without drawings, shall be based on width times span of each panel, with no deduction made for cutouts, unless allowances for cutouts have been negotiated.

## CODE OF PRACTICE

**4.2** Final calculated grating quantities supplied from drawings shall be on the basis of gross area measured center-to-center of supports, or back-to-back of supporting angles or channels, or overall dimensions of grating, whichever is larger, with no deduction for clearances. Allowances for cutouts shall be determined as follows:

- Deductions in area for circular cutouts shall be allowed only when the diameter of the cutout exceeds 3'-6" (1067 mm). The deduction allowance shall be equal to one-half the square of the diameter of the cutout.
- Deductions in the area for cutouts other than circular shall be allowed only when the cutout area exceeds nine (9) square feet (0.836 square meter).
- No deductions shall be allowed for any triangular segment or corners of gratings wasted in skew cuts.
- For special applications, such as (but not limited to) containment areas in nuclear power plants, the final grating quantities shall be the total gross area of all the pieces furnished with no allowance for cutouts. See the following sketches.

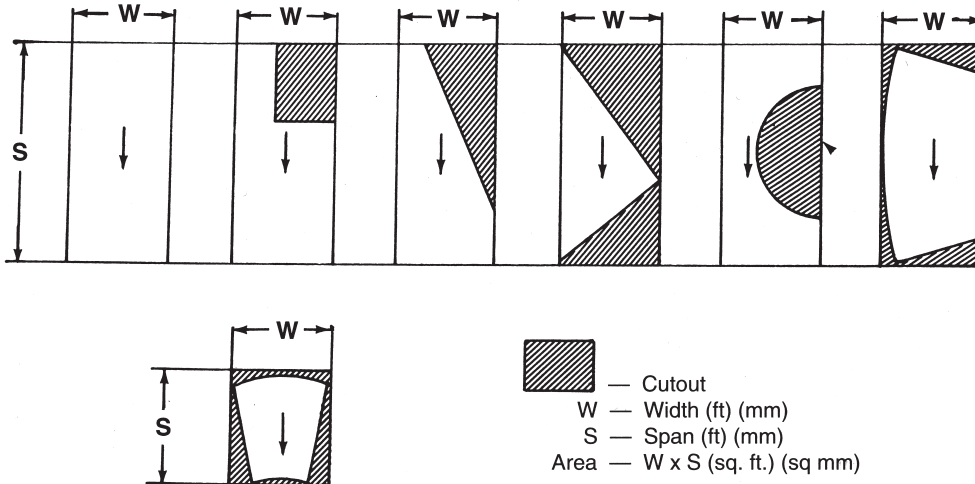

**4.3** Measurement of cuts shall be on the basis of a minimum of one (1) lineal foot (305 mm) per cut per panel. Any cut in excess of one (1) lineal foot (305 mm) shall be measured to the next higher lineal foot (305 mm). (See diagram at the right).

**4.4** Measurement of bandings, toe plates and nosings shall be on the same basis as that of cuts, as defined in 4.3.

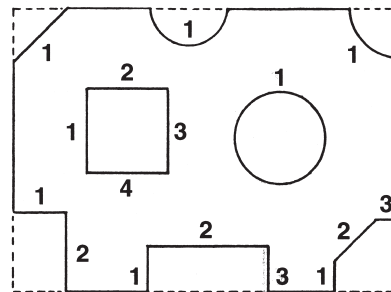

*Diagram showing number of cuts required*

## CODE OF PRACTICE

**5. CHANGES IN SCOPE OF CONTACT**

- 5.1 If at any time during the course of the work the Buyer orders changes made which require materials and/or labor not called for in the original bidding plans, the cost of making such changes shall be paid by the Buyer at a price to be agreed upon.

**6. FIELD WORK**

- 6.1 The Seller shall not be responsible for taking actual measurements on construction work in the field.
- 6.2 Backcharges for field work of any kind are not acceptable without prior written authorization by the grating supplier.

**7. BACKCHARGES**

- 7.1 Upon discovery of unsatisfactory material, the Buyer shall immediately notify the Seller.
- 7.2 The Seller shall acknowledge receipt of the Buyer's complaint and initiate an investigation.
- 7.3 The Seller shall be given the opportunity to inspect the material PRIOR TO ANY CORRECTIVE WORK BEING DONE.
- 7.4 Seller is responsible for providing grating in accordance with approved drawings and specifications. Seller is not responsible for field changes, drawing changes not received and approved by Seller prior to grating fabrication, improper fabrication and/or erection of supporting members.
- 7.5 If the investigation and inspection confirm errors in Seller fabrication, the Seller agrees to repair and/or replace defective material at no charge to the Buyer.

## LOAD AND DEFLECTION TABLES FOR WELDED AND RIVETED HEAVY DUTY CARBON STEEL GRATINGS

The load and deflection tables on the following pages have been prepared to provide the designer with a convenient reference for the load carrying capabilities of typical heavy duty grating constructions offered by NAAMM members.

### Static Loads

Uniform loads and concentrated loads per foot of grating width are given on six inch increments for simple spans ranging from one foot to eight feet. Metric tables provide loads per meter of grating width in 152.4 millimeters increments for spans from 304.8 millimeters to 2438.4 millimeters. The values in these load tables are based on allowable stresses for static loads.

### Vehicular Loads

Vehicular load tables are designed in accordance with the 16th addition of the American Association of State Highway and Transportation Officials (AASHTO) for H-15 through H-25 loads with deflection limited to the lesser of .125 inches (3.175 mm) or L/400 to a maximum simple span of 8'- 0" (2,438mm). Automobile and forklift loads are similarly evaluated with loads calculated and distributed in accordance with the criteria shown below. If the load conditions of your application are not adequately addressed in the criteria presented, please contact NAAMM or any manufacturer of heavy duty bar grating for assistance in determining the proper grating for your application.

Vehicular Load Table Criteria	H-25	H-20	H-15	Passenger Vehicles	5 Ton Forklifts	3 Ton Forklifts	1 Ton Forklifts
Truck/Vehicle Weight				6,322	14,400	9,800	4,200
Load Capacity				3,578	10,000	6,000	2,000
Axle Load (pounds)	40,000	32,000	24,000				
Impact Factor	30%	30%	30%	30%	30%	30%	30%
Total Load (pounds)	52,000	41,600	31,200	12,870	31,720	20,540	8,060
% of load on drive axle				60%	85%	85%	85%
Wheel load (pounds)	26,000	20,800	15,600	3,861	13,481	8,730	3,426
Length of distribution perpendicular to axle or parallel to main bars (inches)	25	20	15	9	11	7	4
Width of distribution parallel to axle or perpendicular to main bars (inches)	25*	20*	15*	9*	11*	7*	4*
*plus 2 times the center/center spacing of the bearing bars							

### Riveted Gratings

The vehicular load tables for riveted grating are computed using the same load distribution methods as welded grating. Section properties for riveted gratings were developed using Parallel Axis Theorem for determining the centroid and "I" for each bar size. In this calculation, the reticulate bars, which are riveted to the bearing bars, contribute to the longitudinal strength of the grating, thereby increasing the load carrying capacity of the grating. Riveted products presented in this catalog shall have a minimum 1-1/2" x 3/16" reticulate bar.

**STATIC  
LOAD  
TABLES**

**W-19-4 HEAVY DUTY WELDED STEEL GRATING****(Chart continues on page 22)**

No. Bars/Ft. of Width		10.105		Allowable Fiber Stress		20,000 psi			
U—Uniform Load, Pounds per Square Foot				C—Concentrated Load, Pounds per Foot of Width		D—Deflection, Inches			
Bearing Bar Size in.	Section Modulus in <sup>3</sup> per ft. of width	Moment Inertia in <sup>4</sup>	Approx. Weight* lb/sq.ft.	Span in Inches					
					12	18	24	30	36
1 x 1/4	0.421	0.211	9.7	U	5613	2495	1403	898	624
				Du	0.021	0.046	0.083	0.129	0.186
				C	2807	1871	1403	1123	936
				Dc	0.017	0.037	0.066	0.103	0.149
1 x 3/8	0.632	0.316	14.0	U	8427	3745	2107	1348	936
				Du	0.021	0.047	0.083	0.129	0.186
				C	4213	2809	2107	1685	1404
				Dc	0.017	0.037	0.066	0.103	0.149
1 1/4 x 1/4	0.658	0.411	11.9	U	8773	3899	2193	1404	975
				Du	0.017	0.037	0.066	0.104	0.149
				C	4387	2924	2193	1755	1462
				Dc	0.013	0.030	0.053	0.083	0.119
1 1/4 x 3/8	0.987	0.617	17.2	U	13160	5849	3290	2106	1462
				Du	0.017	0.037	0.066	0.103	0.149
				C	6580	4387	3290	2632	2193
				Dc	0.013	0.030	0.053	0.083	0.119
1 1/2 x 1/4	0.947	0.711	14.0	U	12627	5612	3157	2020	1403
				Du	0.014	0.031	0.055	0.086	0.124
				C	6313	4209	3157	2525	2104
				Dc	0.011	0.025	0.044	0.069	0.099
1 1/2 x 3/8	1.421	1.066	20.5	U	18947	8421	4737	3031	2105
				Du	0.014	0.031	0.055	0.086	0.124
				C	9473	6316	4737	3789	3158
				Dc	0.011	0.025	0.044	0.069	0.099
1 3/4 x 1/4	1.289	1.128	16.2	U	17187	7639	4297	2750	1910
				Du	0.012	0.027	0.047	0.074	0.106
				C	8593	5729	4297	3437	2864
				Dc	0.010	0.021	0.038	0.059	0.085
1 3/4 x 3/8	1.934	1.692	23.7	U	25787	11461	6447	4126	2865
				Du	0.012	0.027	0.047	0.074	0.106
				C	12893	8596	6447	5157	4298
				Dc	0.010	0.021	0.038	0.059	0.085
2 x 1/4	1.684	1.684	18.3	U	22453	9979	5613	3593	2495
				Du	0.010	0.023	0.041	0.065	0.093
				C	11227	7484	5613	4491	3742
				Dc	0.008	0.019	0.033	0.052	0.075
2 x 3/8	2.526	2.526	26.9	U	33680	14969	8420	5389	3742
				Du	0.010	0.023	0.041	0.065	0.093
				C	16840	11227	8420	6736	5613
				Dc	0.008	0.019	0.033	0.052	0.075
2 1/4 x 1/4	2.132	2.398	20.5	U	28427	12634	7107	4548	3159
				Du	0.009	0.021	0.037	0.058	0.083
				C	14213	9476	7107	5685	4738
				Dc	0.007	0.017	0.029	0.046	0.066
2 1/4 x 3/8	3.197	3.597	30.1	U	42627	18945	10657	6820	4736
				Du	0.009	0.021	0.037	0.058	0.083
				C	21313	14209	10657	8525	7104
				Dc	0.007	0.017	0.029	0.046	0.066

NOTE: When serrated grating is specified, the depth of grating required for specific load will be the next depth greater than that shown in these tables.

Loads above DO NOT include the dead load of the grating.



**STATIC  
LOAD  
TABLES**

(Chart begins on page 21)

U—Uniform Load, Pounds per Square Foot		C—Concentrated Load, Pounds per Foot of Width						D—Deflection, Inches	
Span in Inches									
42	48	54	60	66	72	78	84	90	96
458	351	277	225	186	156	133	115	100	88
0.253	0.330	0.418	0.517	0.626	0.743	0.873	1.015	1.163	1.325
802	702	624	561	510	468	432	401	374	351
0.202	0.264	0.335	0.413	0.499	0.595	0.698	0.809	0.928	1.057
688	527	416	337	279	234	199	172	150	132
0.254	0.331	0.419	0.517	0.627	0.745	0.872	1.014	1.165	1.328
1204	1053	936	843	766	702	648	602	562	527
0.203	0.265	0.335	0.414	0.501	0.596	0.699	0.811	0.931	1.060
716	548	433	351	290	244	208	179	156	137
0.203	0.265	0.335	0.414	0.501	0.597	0.701	0.811	0.932	1.059
1253	1097	975	877	798	731	675	627	585	548
0.162	0.212	0.268	0.331	0.401	0.477	0.560	0.650	0.745	0.847
1074	823	650	526	435	366	311	269	234	206
0.203	0.265	0.335	0.413	0.501	0.597	0.698	0.812	0.931	1.061
1880	1645	1462	1316	1196	1097	1012	940	877	823
0.162	0.212	0.268	0.331	0.400	0.477	0.559	0.649	0.744	0.848
1031	789	624	505	417	351	299	258	224	197
0.169	0.220	0.279	0.344	0.416	0.496	0.582	0.676	0.773	0.881
1804	1578	1403	1263	1148	1052	971	902	842	789
0.135	0.176	0.223	0.276	0.334	0.397	0.466	0.540	0.620	0.705
1547	1184	936	758	626	526	448	387	337	296
0.169	0.221	0.279	0.345	0.417	0.496	0.582	0.676	0.776	0.882
2707	2368	2105	1895	1722	1579	1457	1353	1263	1184
0.135	0.177	0.223	0.276	0.334	0.397	0.466	0.540	0.621	0.706
1403	1074	849	687	568	477	407	351	306	269
0.145	0.189	0.240	0.295	0.358	0.425	0.500	0.580	0.666	0.758
2455	2148	1910	1719	1562	1432	1322	1228	1146	1074
0.116	0.151	0.192	0.237	0.286	0.340	0.400	0.464	0.532	0.605
2105	1612	1273	1031	852	716	610	526	458	403
0.145	0.189	0.239	0.296	0.358	0.426	0.499	0.579	0.665	0.757
3684	3223	2865	2579	2344	2149	1984	1842	1719	1612
0.116	0.151	0.192	0.237	0.286	0.341	0.400	0.464	0.532	0.606
1833	1403	1109	898	742	624	531	458	399	351
0.127	0.166	0.210	0.259	0.313	0.373	0.437	0.507	0.582	0.662
3208	2807	2495	2245	2041	1871	1727	1604	1497	1403
0.101	0.132	0.168	0.207	0.250	0.298	0.350	0.406	0.466	0.530
2749	2105	1663	1347	1113	936	797	687	599	526
0.127	0.166	0.210	0.259	0.313	0.373	0.437	0.507	0.582	0.662
4811	4210	3742	3368	3062	2807	2591	2406	2245	2105
0.101	0.132	0.168	0.207	0.250	0.298	0.350	0.406	0.465	0.530
2321	1777	1404	1137	940	790	673	580	505	444
0.113	0.147	0.186	0.230	0.278	0.331	0.389	0.451	0.517	0.588
4061	3553	3159	2843	2584	2369	2187	2030	1895	1777
0.090	0.118	0.149	0.184	0.223	0.265	0.311	0.361	0.414	0.471
3480	2664	2105	1705	1409	1184	1009	870	758	666
0.113	0.147	0.186	0.230	0.278	0.331	0.389	0.451	0.517	0.588
6090	5328	4736	4263	3875	3552	3279	3045	2842	2664
0.090	0.118	0.149	0.184	0.223	0.265	0.311	0.361	0.414	0.471

\*Weight depends on panel width, cross bar selection, mill tolerance and manufacturing tolerance.

Loads above DO NOT include the dead load of the grating.

**STATIC  
LOAD  
TABLES**

**W-19-4 HEAVY DUTY WELDED STEEL GRATING (Con't.) (Chart continues on page 24)**

No. Bars/Ft. of Width		10.105		Allowable Fiber Stress		20,000 psi			
U—Uniform Load, Pounds per Square Foot				C—Concentrated Load, Pounds per Foot of Width		D—Deflection, Inches			
Bearing Bar Size in.	Section Modulus in. <sup>3</sup> per ft. of width	Moment Inertia in. <sup>4</sup>	Approx. Weight* lb/sqft	Span in Inches					
					12	18	24	30	36
2 1/2 x 1/4	2.632	3.289	22.6	U	35093	15597	8773	5615	3899
				Du	0.008	0.019	0.033	0.052	0.075
				C	17547	11698	8773	7019	5849
				Dc	0.007	0.015	0.027	0.041	0.060
2 1/2 x 3/8	3.947	4.934	33.3	U	52627	23390	13157	8420	5847
				Du	0.008	0.019	0.033	0.052	0.075
				C	26313	17542	13157	10525	8771
				Dc	0.007	0.015	0.027	0.041	0.060
3 x 1/4	3.789	5.684	26.9	U	50520	22453	12630	8083	5613
				Du	0.007	0.016	0.028	0.043	0.062
				C	25260	16840	12630	10104	8420
				Dc	0.006	0.012	0.022	0.035	0.050
3 x 3/8	5.684	8.526	39.8	U	75787	33683	18947	12126	8421
				Du	0.007	0.016	0.028	0.043	0.062
				C	37893	25262	18947	15157	12631
				Dc	0.006	0.012	0.022	0.035	0.050
3 1/2 x 1/4	5.158	9.026	31.2	U	68773	30566	17193	11004	7641
				Du	0.006	0.013	0.024	0.037	0.053
				C	34387	22924	17193	13755	11462
				Dc	0.005	0.011	0.019	0.030	0.043
3 1/2 x 3/8	7.737	13.539	46.2	U	103160	45849	25790	16506	11462
				Du	0.006	0.013	0.024	0.037	0.053
				C	51580	34387	25790	20632	17193
				Dc	0.005	0.011	0.019	0.030	0.043
4 x 1/4	6.737	13.473	35.5	U	89827	39923	22457	14372	9981
				Du	0.005	0.012	0.021	0.032	0.047
				C	44913	29942	22457	17965	14971
				Dc	0.004	0.009	0.017	0.026	0.037
4 x 3/8	10.105	20.210	52.7	U	134733	59881	33683	21557	14970
				Du	0.005	0.012	0.021	0.032	0.047
				C	67367	44911	33683	26947	22456
				Dc	0.004	0.009	0.017	0.026	0.037
4 1/2 x 1/4	8.526	19.184	39.8	U	113680	50524	28420	18189	12631
				Du	0.005	0.010	0.018	0.029	0.041
				C	56840	37893	28420	22736	18947
				Dc	0.004	0.008	0.015	0.023	0.033
4 1/2 x 3/8	12.789	28.776	59.1	U	170520	75787	42630	27283	18947
				Du	0.005	0.010	0.018	0.029	0.041
				C	85260	56840	42630	34104	28420
				Dc	0.004	0.008	0.015	0.023	0.033
5 x 1/4	10.526	26.315	44.1	U	140347	62376	35087	22455	15594
				Du	0.004	0.009	0.017	0.026	0.037
				C	70173	46782	35087	28069	23391
				Dc	0.003	0.007	0.013	0.021	0.030
5 x 3/8	15.789	39.473	65.5	U	210520	93564	52630	33683	23391
				Du	0.004	0.009	0.017	0.026	0.037
				C	105260	70173	52630	42104	35087
				Dc	0.003	0.007	0.013	0.021	0.030

NOTE: When serrated grating is specified, the depth of grating required for specific load will be the next depth greater than that shown in these tables.

Loads above DO NOT include the dead load of the grating.

**STATIC  
LOAD  
TABLES**

**(Chart begins on page 23)**

U—Uniform Load, Pounds per Square Foot    C—Concentrated Load, Pounds per Foot of Width    D—Deflection, Inches									
Span in Inches									
42	48	54	60	66	72	78	84	90	96
2865	2193	1733	1404	1160	975	831	716	624	548
0.101	0.132	0.168	0.207	0.250	0.298	0.350	0.406	0.466	0.530
5013	4387	3899	3509	3190	2924	2699	2507	2340	2193
0.081	0.106	0.134	0.166	0.200	0.238	0.280	0.325	0.373	0.424
4296	3289	2599	2105	1740	1462	1246	1074	936	822
0.101	0.132	0.168	0.207	0.250	0.298	0.350	0.406	0.466	0.529
7518	6578	5847	5263	4784	4386	4048	3759	3508	3289
0.081	0.106	0.134	0.166	0.200	0.238	0.280	0.324	0.372	0.424
4124	3158	2495	2021	1670	1403	1196	1031	898	789
0.085	0.110	0.140	0.172	0.209	0.248	0.291	0.338	0.388	0.441
7217	6315	5613	5052	4593	4210	3886	3609	3368	3158
0.068	0.088	0.112	0.138	0.167	0.199	0.233	0.270	0.310	0.353
6187	4737	3743	3031	2505	2105	1794	1547	1347	1184
0.085	0.110	0.140	0.172	0.209	0.248	0.291	0.338	0.388	0.441
10827	9473	8421	7579	6890	6316	5830	5413	5052	4737
0.068	0.088	0.112	0.138	0.167	0.199	0.233	0.270	0.310	0.353
5614	4298	3396	2751	2273	1910	1628	1404	1223	1075
0.072	0.095	0.120	0.148	0.179	0.213	0.250	0.290	0.333	0.379
9825	8597	7641	6877	6252	5731	5290	4912	4585	4298
0.058	0.076	0.096	0.118	0.143	0.170	0.200	0.232	0.266	0.303
8421	6448	5094	4126	3410	2866	2442	2105	1834	1612
0.072	0.095	0.120	0.148	0.179	0.213	0.250	0.290	0.333	0.378
14737	12895	11462	10316	9378	8597	7935	7369	6877	6448
0.058	0.076	0.096	0.118	0.143	0.170	0.200	0.232	0.266	0.303
7333	5614	4436	3593	2969	2495	2126	1833	1597	1404
0.063	0.083	0.105	0.129	0.157	0.186	0.219	0.253	0.291	0.331
12832	11228	9981	8983	8166	7486	6910	6416	5988	5614
0.051	0.066	0.084	0.104	0.125	0.149	0.175	0.203	0.233	0.265
10999	8421	6653	5389	4454	3743	3189	2750	2395	2105
0.063	0.083	0.105	0.129	0.157	0.186	0.219	0.254	0.291	0.331
19248	16842	14970	13473	12248	11228	10364	9624	8982	8421
0.051	0.066	0.084	0.103	0.125	0.149	0.175	0.203	0.233	0.265
9280	7105	5614	4547	3758	3158	2691	2320	2021	1776
0.056	0.074	0.093	0.115	0.139	0.166	0.194	0.225	0.259	0.294
16240	14210	12631	11368	10335	9473	8745	8120	7579	7105
0.045	0.059	0.075	0.092	0.111	0.132	0.155	0.180	0.207	0.235
13920	10658	8421	6821	5637	4737	4036	3480	3031	2664
0.056	0.074	0.093	0.115	0.139	0.166	0.194	0.225	0.259	0.294
24360	21315	18947	17052	15502	14210	13117	12180	11368	10658
0.045	0.059	0.075	0.092	0.111	0.132	0.155	0.180	0.207	0.235
11457	8772	6931	5614	4640	3899	3322	2864	2495	2193
0.051	0.066	0.084	0.104	0.125	0.149	0.175	0.203	0.233	0.265
20050	17543	15594	14035	12759	11696	10796	10025	9356	8772
0.041	0.053	0.067	0.083	0.100	0.119	0.140	0.162	0.186	0.212
17185	13158	10396	8421	6959	5848	4983	4296	3743	3289
0.051	0.066	0.084	0.103	0.125	0.149	0.175	0.203	0.233	0.265
30074	26315	23391	21052	19138	17543	16194	15037	14035	13158
0.041	0.053	0.067	0.083	0.100	0.119	0.140	0.162	0.186	0.212

\*Weight depends on panel width, cross bar selection, mill tolerance and manufacturing tolerance.

Loads above DO NOT include the dead load of the grating.



**STATIC  
LOAD  
TABLES**

**W-22-4 HEAVY DUTY WELDED STEEL GRATING****(Chart continues on page 26)**

No. Bars/Ft. of Width				Allowable Fiber Stress					
8.727				20,000 psi					
U—Uniform Load, Pounds per Square Foot				C—Concentrated Load, Pounds per Foot of Width			D—Deflection, Inches		
Bearing Bar Size in.	Section Modulus in. <sup>3</sup> per. ft. of width	Moment Inertia in. <sup>4</sup>	Approx. Weight* lb/sqft	Span in Inches					
				12	18	24	30	36	
1 x 1/4	0.364	0.182	8.5	U	4853	2157	1213	777	539
				Du	0.021	0.047	0.083	0.129	0.186
				C	2427	1618	1213	971	809
				Dc	0.017	0.037	0.066	0.104	0.149
1 x 3/8	0.545	0.273	12.3	U	7267	3230	1817	1163	807
				Du	0.021	0.047	0.083	0.129	0.186
				C	3633	2422	1817	1453	1211
				Dc	0.017	0.037	0.066	0.103	0.149
1 1/4 x 1/4	0.568	0.355	10.4	U	7573	3366	1893	1212	841
				Du	0.017	0.037	0.066	0.104	0.149
				C	3787	2524	1893	1515	1262
				Dc	0.013	0.030	0.053	0.083	0.119
1 1/4 x 3/8	0.852	0.533	15.0	U	11360	5049	2840	1818	1262
				Du	0.017	0.037	0.066	0.103	0.149
				C	5680	3787	2840	2272	1893
				Dc	0.013	0.030	0.053	0.083	0.119
1 1/2 x 1/4	0.818	0.614	12.3	U	10907	4847	2727	1745	1212
				Du	0.014	0.031	0.055	0.086	0.124
				C	5453	3636	2727	2181	1818
				Dc	0.011	0.025	0.044	0.069	0.099
1 1/2 x 3/8	1.227	0.92	17.8	U	16360	7271	4090	2618	1818
				Du	0.014	0.031	0.055	0.086	0.124
				C	8180	5453	4090	3272	2727
				Dc	0.011	0.025	0.044	0.069	0.099
1 3/4 x 1/4	1.114	0.974	14.1	U	14853	6601	3713	2377	1650
				Du	0.012	0.027	0.047	0.074	0.107
				C	7427	4951	3713	2971	2476
				Dc	0.010	0.021	0.038	0.059	0.085
1 3/4 x 3/8	1.67	1.462	20.6	U	22267	9896	5567	3563	2474
				Du	0.012	0.027	0.047	0.074	0.106
				C	11133	7422	5567	4453	3711
				Dc	0.010	0.021	0.038	0.059	0.085
2 x 1/4	1.455	1.455	16.0	U	19400	8622	4850	3104	2156
				Du	0.010	0.023	0.041	0.065	0.093
				C	9700	6467	4850	3880	3233
				Dc	0.008	0.019	0.033	0.052	0.075
2 x 3/8	2.182	2.182	23.4	U	29093	12930	7273	4655	3233
				Du	0.010	0.023	0.041	0.065	0.093
				C	14547	9698	7273	5819	4849
				Dc	0.008	0.019	0.033	0.052	0.075
2 1/4 x 1/4	1.841	2.071	17.8	U	24547	10910	6137	3927	2727
				Du	0.009	0.021	0.037	0.058	0.083
				C	12273	8182	6137	4909	4091
				Dc	0.007	0.017	0.029	0.046	0.066
2 1/4 x 3/8	2.761	3.106	26.2	U	36813	16361	9203	5890	4090
				Du	0.009	0.021	0.037	0.058	0.083
				C	18407	12271	9203	7363	6136
				Dc	0.007	0.017	0.029	0.046	0.066

NOTE: When serrated grating is specified, the depth of grating required for specific load will be the next depth greater than that shown in these tables.

Loads above DO NOT include the dead load of the grating.

**STATIC  
LOAD  
TABLES**

**(Chart begins on page 25)**

U—Uniform Load, Pounds per Square Foot		C—Concentrated Load, Pounds per Foot of Width				D—Deflection, Inches			
Span in Inches									
42	48	54	60	66	72	78	84	90	96
396	303	240	194	160	135	115	99	86	76
0.253	0.331	0.420	0.517	0.624	0.746	0.875	1.013	1.160	1.327
693	607	539	485	441	404	373	347	324	303
0.203	0.265	0.335	0.414	0.500	0.595	0.699	0.812	0.932	1.058
593	454	359	291	240	202	172	148	129	114
0.253	0.330	0.418	0.517	0.624	0.744	0.873	1.010	1.160	1.327
1038	908	807	727	661	606	559	519	484	454
0.202	0.264	0.334	0.413	0.500	0.595	0.698	0.810	0.929	1.057
618	473	374	303	250	210	179	155	135	118
0.203	0.265	0.335	0.414	0.500	0.595	0.698	0.813	0.934	1.056
1082	947	841	757	688	631	583	541	505	473
0.162	0.212	0.268	0.331	0.400	0.477	0.560	0.649	0.745	0.847
927	710	561	454	376	316	269	232	202	178
0.203	0.265	0.335	0.413	0.501	0.596	0.699	0.811	0.930	1.061
1623	1420	1262	1136	1033	947	874	811	757	710
0.162	0.212	0.268	0.331	0.400	0.476	0.559	0.648	0.744	0.847
890	682	539	436	361	303	258	223	194	170
0.169	0.221	0.279	0.344	0.417	0.496	0.582	0.677	0.776	0.880
1558	1363	1212	1091	992	909	839	779	727	682
0.135	0.176	0.223	0.276	0.334	0.397	0.466	0.540	0.620	0.706
1336	1023	808	654	541	454	387	334	291	256
0.169	0.221	0.279	0.345	0.418	0.496	0.583	0.676	0.777	0.884
2337	2045	1818	1636	1487	1363	1258	1169	1091	1023
0.135	0.177	0.224	0.276	0.334	0.397	0.466	0.541	0.621	0.707
1213	928	733	594	491	413	352	303	264	232
0.145	0.189	0.239	0.296	0.358	0.426	0.501	0.580	0.665	0.757
2122	1857	1650	1485	1350	1238	1143	1061	990	928
0.116	0.152	0.192	0.237	0.286	0.341	0.400	0.464	0.532	0.606
1818	1392	1100	891	736	619	527	454	396	348
0.145	0.189	0.239	0.296	0.357	0.426	0.499	0.579	0.665	0.756
3181	2783	2474	2227	2024	1856	1713	1590	1484	1392
0.116	0.151	0.191	0.236	0.286	0.340	0.399	0.463	0.532	0.605
1584	1213	958	776	641	539	459	396	345	303
0.127	0.166	0.210	0.259	0.313	0.373	0.437	0.507	0.582	0.662
2771	2425	2156	1940	1764	1617	1492	1386	1293	1213
0.101	0.132	0.168	0.207	0.250	0.298	0.350	0.406	0.465	0.530
2375	1818	1437	1164	962	808	689	594	517	455
0.127	0.166	0.210	0.259	0.313	0.372	0.437	0.507	0.582	0.663
4156	3637	3233	2909	2645	2424	2238	2078	1940	1818
0.101	0.132	0.168	0.207	0.250	0.298	0.350	0.406	0.466	0.530
2004	1534	1212	982	811	682	581	501	436	384
0.113	0.147	0.186	0.230	0.278	0.331	0.389	0.451	0.517	0.589
3507	3068	2727	2455	2232	2046	1888	1753	1636	1534
0.090	0.118	0.149	0.184	0.223	0.265	0.311	0.360	0.414	0.471
3005	2301	1818	1473	1217	1023	871	751	654	575
0.113	0.147	0.186	0.230	0.278	0.331	0.388	0.450	0.517	0.588
5259	4602	4090	3681	3347	3068	2832	2630	2454	2301
0.090	0.118	0.149	0.184	0.223	0.265	0.311	0.361	0.414	0.471

\*Weight depends on panel width, cross bar selection, mill tolerance and manufacturing tolerance.

Loads above DO NOT include the dead load of the grating.

**STATIC  
LOAD  
TABLES**

**W-22-4 HEAVY DUTY WELDED STEEL GRATING (Con't.) (Chart continues on page 28)**

No. Bars/Ft. of Width				Allowable Fiber Stress					
8.727				20,000 psi					
U—Uniform Load, Pounds per Square Foot				C—Concentrated Load, Pounds per Foot of Width			D—Deflection, Inches		
Bearing Bar Size in.	Section Modulus in. <sup>3</sup> per ft. of width	Moment Inertia in. <sup>4</sup>	Approx. Weight* lb/sqft	Span in Inches					
				12	18	24	30	36	
2½ x ¼	2.273	2.841	19.7	U	30307	13470	7577	4849	3367
				Du	0.008	0.019	0.033	0.052	0.075
				C	15153	10102	7577	6061	5051
				Dc	0.007	0.015	0.027	0.041	0.060
2½ x ⅜	3.409	4.261	28.9	U	45453	20201	11363	7273	5050
				Du	0.008	0.019	0.033	0.052	0.075
				C	22727	15151	11363	9091	7576
				Dc	0.007	0.015	0.027	0.041	0.060
3 x ¼	3.273	4.909	23.4	U	43640	19396	10910	6982	4849
				Du	0.007	0.016	0.028	0.043	0.062
				C	21820	14547	10910	8728	7273
				Dc	0.006	0.012	0.022	0.035	0.050
3 x ⅜	4.909	7.363	34.5	U	65453	29090	16363	10473	7273
				Du	0.007	0.016	0.028	0.043	0.062
				C	32727	21818	16363	13091	10909
				Dc	0.006	0.012	0.022	0.035	0.050
3½ x ¼	4.454	7.795	27.1	U	59387	26394	14847	9502	6599
				Du	0.006	0.013	0.024	0.037	0.053
				C	29693	19796	14847	11877	9898
				Dc	0.005	0.011	0.019	0.030	0.043
3½ x ⅜	6.682	11.693	40.1	U	89093	39597	22273	14255	9899
				Du	0.006	0.013	0.024	0.037	0.053
				C	44547	29698	22273	17819	14849
				Dc	0.005	0.011	0.019	0.030	0.043
4 x ¼	5.818	11.636	30.8	U	77573	34477	19393	12412	8619
				Du	0.005	0.012	0.021	0.032	0.047
				C	38787	25858	19393	15515	12929
				Dc	0.004	0.009	0.017	0.026	0.037
4 x ⅜	8.727	17.454	45.6	U	116360	51716	29090	18618	12929
				Du	0.005	0.012	0.021	0.032	0.047
				C	58180	38787	29090	23272	19393
				Dc	0.004	0.009	0.017	0.026	0.037
4½ x ¼	7.363	16.568	34.5	U	98173	43633	24543	15708	10908
				Du	0.005	0.010	0.018	0.029	0.041
				C	49087	32724	24543	19635	16362
				Dc	0.004	0.008	0.015	0.023	0.033
4½ x ⅜	11.045	24.851	51.2	U	147267	65452	36817	23563	16363
				Du	0.005	0.010	0.018	0.029	0.041
				C	73633	49089	36817	29453	24544
				Dc	0.004	0.008	0.015	0.023	0.033
5 x ¼	9.091	22.727	38.2	U	121213	53873	30303	19394	13468
				Du	0.004	0.009	0.017	0.026	0.037
				C	60607	40404	30303	24243	20202
				Dc	0.003	0.007	0.013	0.021	0.030
5 x ⅜	13.636	34.09	56.8	U	181813	80806	45453	29090	20201
				Du	0.004	0.009	0.017	0.026	0.037
				C	90907	60604	45453	36363	30302
				Dc	0.003	0.007	0.013	0.021	0.030

NOTE: When serrated grating is specified, the depth of grating required for specific load will be the next depth greater than that shown in these tables.

Loads above DO NOT include the dead load of the grating.

**STATIC  
LOAD  
TABLES**

(Chart begins on page 27)

U—Uniform Load, Pounds per Square Foot		C—Concentrated Load, Pounds per Foot of Width						D—Deflection, Inches	
Span in Inches									
42	48	54	60	66	72	78	84	90	96
2474	1894	1497	1212	1002	842	717	619	539	474
0.101	0.132	0.168	0.207	0.250	0.298	0.350	0.406	0.466	0.530
4330	3788	3367	3031	2755	2526	2331	2165	2020	1894
0.081	0.106	0.134	0.166	0.200	0.238	0.280	0.325	0.372	0.424
3710	2841	2245	1818	1503	1263	1076	928	808	710
0.101	0.132	0.168	0.207	0.250	0.298	0.350	0.406	0.466	0.530
6493	5682	5050	4545	4132	3788	3496	3247	3030	2841
0.081	0.106	0.134	0.166	0.200	0.238	0.280	0.325	0.372	0.424
3562	2728	2155	1746	1443	1212	1033	891	776	682
0.085	0.110	0.140	0.173	0.209	0.248	0.291	0.338	0.388	0.442
6234	5455	4849	4364	3967	3637	3357	3117	2909	2728
0.068	0.088	0.112	0.138	0.167	0.199	0.233	0.270	0.310	0.353
5343	4091	3232	2618	2164	1818	1549	1336	1164	1023
0.085	0.110	0.140	0.172	0.209	0.248	0.291	0.338	0.388	0.442
9350	8182	7273	6545	5950	5454	5035	4675	4364	4091
0.068	0.088	0.112	0.138	0.167	0.199	0.233	0.270	0.310	0.353
4848	3712	2933	2375	1963	1650	1406	1212	1056	928
0.072	0.095	0.120	0.148	0.179	0.213	0.250	0.290	0.333	0.378
8484	7423	6599	5939	5399	4949	4568	4242	3959	3712
0.058	0.076	0.096	0.118	0.143	0.170	0.200	0.232	0.266	0.303
7273	5568	4400	3564	2945	2475	2109	1818	1584	1392
0.072	0.095	0.120	0.148	0.179	0.213	0.250	0.290	0.333	0.378
12728	11137	9899	8909	8099	7424	6853	6364	5940	5568
0.058	0.076	0.096	0.118	0.143	0.170	0.200	0.232	0.266	0.303
6333	4848	3831	3103	2564	2155	1836	1583	1379	1212
0.063	0.083	0.105	0.129	0.156	0.186	0.219	0.253	0.291	0.331
11082	9697	8619	7757	7052	6464	5967	5541	5172	4848
0.051	0.066	0.084	0.103	0.125	0.149	0.175	0.203	0.233	0.265
9499	7273	5746	4654	3847	3232	2754	2375	2069	1818
0.063	0.083	0.105	0.129	0.157	0.186	0.219	0.254	0.291	0.331
16623	14545	12929	11636	10578	9697	8951	8311	7757	7273
0.051	0.066	0.084	0.103	0.125	0.149	0.175	0.203	0.233	0.265
8014	6136	4848	3927	3245	2727	2324	2004	1745	1534
0.056	0.074	0.093	0.115	0.139	0.166	0.194	0.225	0.259	0.294
14025	12272	10908	9817	8925	8181	7552	7012	6545	6136
0.045	0.059	0.075	0.092	0.111	0.132	0.155	0.180	0.207	0.235
12022	9204	7272	5891	4868	4091	3486	3005	2618	2301
0.056	0.074	0.093	0.115	0.139	0.166	0.194	0.225	0.259	0.294
21038	18408	16363	14727	13388	12272	11328	10519	9818	9204
0.045	0.059	0.075	0.092	0.111	0.132	0.155	0.180	0.207	0.235
9895	7576	5986	4849	4007	3367	2869	2474	2155	1894
0.051	0.066	0.084	0.104	0.125	0.149	0.175	0.203	0.233	0.265
17316	15152	13468	12121	11019	10101	9324	8658	8081	7576
0.041	0.053	0.067	0.083	0.100	0.119	0.140	0.162	0.186	0.212
14842	11363	8978	7273	6010	5050	4303	3710	3232	2841
0.051	0.066	0.084	0.104	0.125	0.149	0.175	0.203	0.233	0.265
25973	22727	20201	18181	16528	15151	13986	12987	12121	11363
0.041	0.053	0.067	0.083	0.100	0.119	0.140	0.162	0.186	0.212

\*Weight depends on panel width, cross bar selection, mill tolerance and manufacturing tolerance.

Loads above DO NOT include the dead load of the grating.



**STATIC  
LOAD  
TABLES**

**W-30-4 HEAVY DUTY WELDED STEEL GRATING****(Chart continues on page 30)**

No. Bars/Ft. of Width		6.400		Allowable Fiber Stress		20,000 psi			
U—Uniform Load, Pounds per Square Foot				C—Concentrated Load, Pounds per Foot of Width		D—Deflection, Inches			
Bearing Bar Size in.	Section Modulus in. <sup>3</sup> per. ft. of width	Moment Inertia in. <sup>4</sup>	Approx. Weight* lb/sqft	Span in Inches					
					12	18	24	30	36
1 x 1/4	0.267	0.133	6.6	U	3560	1582	890	570	396
				Du	0.021	0.047	0.083	0.130	0.187
				C	1780	1187	890	712	593
				Dc	0.017	0.037	0.067	0.104	0.149
1 x 3/8	0.4	0.2	9.3	U	5333	2370	1333	853	593
				Du	0.021	0.047	0.083	0.129	0.186
				C	2667	1778	1333	1067	889
				Dc	0.017	0.037	0.066	0.104	0.149
1 1/4 x 1/4	0.417	0.26	7.9	U	5560	2471	1390	890	618
				Du	0.017	0.037	0.066	0.104	0.149
				C	2780	1853	1390	1112	927
				Dc	0.013	0.030	0.053	0.083	0.120
1 1/4 x 3/8	0.625	0.391	11.3	U	8333	3704	2083	1333	926
				Du	0.017	0.037	0.066	0.103	0.149
				C	4167	2778	2083	1667	1389
				Dc	0.013	0.030	0.053	0.083	0.119
1 1/2 x 1/4	0.6	0.45	9.3	U	8000	3556	2000	1280	889
				Du	0.014	0.031	0.055	0.086	0.124
				C	4000	2667	2000	1600	1333
				Dc	0.011	0.025	0.044	0.069	0.099
1 1/2 x 3/8	0.9	0.675	13.4	U	12000	5333	3000	1920	1333
				Du	0.014	0.031	0.055	0.086	0.124
				C	6000	4000	3000	2400	2000
				Dc	0.011	0.025	0.044	0.069	0.099
1 3/4 x 1/4	0.817	0.715	10.6	U	10893	4841	2723	1743	1210
				Du	0.012	0.027	0.047	0.074	0.106
				C	5447	3631	2723	2179	1816
				Dc	0.010	0.021	0.038	0.059	0.085
1 3/4 x 3/8	1.225	1.072	15.4	U	16333	7259	4083	2613	1815
				Du	0.012	0.027	0.047	0.074	0.106
				C	8167	5444	4083	3267	2722
				Dc	0.010	0.021	0.038	0.059	0.085
2 x 1/4	1.067	1.067	12.0	U	14227	6323	3557	2276	1581
				Du	0.010	0.023	0.041	0.065	0.093
				C	7113	4742	3557	2845	2371
				Dc	0.008	0.019	0.033	0.052	0.075
2 x 3/8	1.6	1.6	17.4	U	21333	9481	5333	3413	2370
				Du	0.010	0.023	0.041	0.065	0.093
				C	10667	7111	5333	4267	3556
				Dc	0.008	0.019	0.033	0.052	0.075
2 1/4 x 1/4	1.35	1.519	13.4	U	18000	8000	4500	2880	2000
				Du	0.009	0.021	0.037	0.058	0.083
				C	9000	6000	4500	3600	3000
				Dc	0.007	0.017	0.029	0.046	0.066
2 1/4 x 3/8	2.025	2.278	19.5	U	27000	12000	6750	4320	3000
				Du	0.009	0.021	0.037	0.058	0.083
				C	13500	9000	6750	5400	4500
				Dc	0.007	0.017	0.029	0.046	0.066

NOTE: When serrated grating is specified, the depth of grating required for specific load will be the next depth greater than that shown in these tables.

Loads above DO NOT include the dead load of the grating.

**STATIC  
LOAD  
TABLES**

(Chart begins on page 29)

U—Uniform Load, Pounds per Square Foot		C—Concentrated Load, Pounds per Foot of Width						D—Deflection, Inches	
Span in Inches									
42	48	54	60	66	72	78	84	90	96
291	223	176	142	118	99	84	73	63	56
0.255	0.333	0.421	0.518	0.630	0.749	0.875	1.023	1.163	1.338
509	445	396	356	324	297	274	254	237	223
0.204	0.266	0.337	0.415	0.503	0.599	0.702	0.813	0.933	1.066
435	333	263	213	176	148	126	109	95	83
0.253	0.331	0.418	0.516	0.625	0.744	0.873	1.015	1.166	1.319
762	667	593	533	485	444	410	381	356	333
0.203	0.265	0.335	0.414	0.501	0.595	0.699	0.811	0.932	1.058
454	348	275	222	184	154	132	113	99	87
0.203	0.266	0.337	0.414	0.502	0.596	0.703	0.810	0.935	1.063
794	695	618	556	505	463	428	397	371	348
0.163	0.212	0.269	0.332	0.401	0.478	0.561	0.650	0.747	0.851
680	521	412	333	275	231	197	170	148	130
0.203	0.265	0.335	0.413	0.499	0.594	0.698	0.810	0.929	1.057
1190	1042	926	833	758	694	641	595	556	521
0.162	0.212	0.268	0.331	0.400	0.476	0.559	0.648	0.745	0.847
653	500	395	320	264	222	189	163	142	125
0.169	0.221	0.279	0.345	0.417	0.496	0.582	0.675	0.775	0.883
1143	1000	889	800	727	667	615	571	533	500
0.135	0.177	0.224	0.276	0.334	0.397	0.466	0.540	0.620	0.706
980	750	593	480	397	333	284	245	213	188
0.169	0.221	0.280	0.345	0.418	0.496	0.583	0.676	0.775	0.885
1714	1500	1333	1200	1091	1000	923	857	800	750
0.135	0.177	0.223	0.276	0.334	0.397	0.466	0.541	0.621	0.706
889	681	538	436	360	303	258	222	194	170
0.145	0.189	0.239	0.296	0.358	0.426	0.500	0.578	0.666	0.756
1556	1362	1210	1089	990	908	838	778	726	681
0.116	0.151	0.191	0.236	0.286	0.341	0.400	0.463	0.532	0.605
1333	1021	807	653	540	454	387	333	290	255
0.145	0.189	0.240	0.295	0.358	0.426	0.500	0.579	0.664	0.756
2333	2042	1815	1633	1485	1361	1256	1167	1089	1021
0.116	0.151	0.192	0.236	0.286	0.340	0.399	0.464	0.532	0.605
1161	889	703	569	470	395	337	290	253	222
0.127	0.166	0.210	0.259	0.313	0.372	0.437	0.506	0.582	0.661
2032	1778	1581	1423	1293	1186	1094	1016	948	889
0.101	0.132	0.168	0.207	0.250	0.298	0.350	0.405	0.465	0.530
1741	1333	1053	853	705	593	505	435	379	333
0.127	0.166	0.209	0.259	0.313	0.373	0.437	0.507	0.582	0.661
3048	2667	2370	2133	1939	1778	1641	1524	1422	1333
0.101	0.132	0.168	0.207	0.250	0.298	0.350	0.406	0.465	0.530
1469	1125	889	720	595	500	426	367	320	281
0.113	0.147	0.186	0.230	0.278	0.331	0.388	0.450	0.517	0.588
2571	2250	2000	1800	1636	1500	1385	1286	1200	1125
0.090	0.118	0.149	0.184	0.222	0.265	0.311	0.361	0.414	0.471
2204	1688	1333	1080	893	750	639	551	480	422
0.113	0.147	0.186	0.230	0.278	0.331	0.389	0.451	0.517	0.589
3857	3375	3000	2700	2455	2250	2077	1929	1800	1688
0.090	0.118	0.149	0.184	0.223	0.265	0.311	0.361	0.414	0.471

\*Weight depends on panel width, cross bar selection, mill tolerance and manufacturing tolerance.

Loads above DO NOT include the dead load of the grating.

**STATIC  
LOAD  
TABLES**

**W-30-4 HEAVY DUTY WELDED STEEL GRATING (Con't.)** (Chart continues on page 32)

No. Bars/Ft. of Width		6.400		Allowable Fiber Stress		20,000 psi			
U—Uniform Load, Pounds per Square Foot				C—Concentrated Load, Pounds per Foot of Width		D—Deflection, Inches			
Bearing Bar Size in.	Section Modulus in. <sup>3</sup> per ft. of width	Moment Inertia in. <sup>4</sup>	Approx. Weight* lb/sqft	Span in Inches					
				12	18	24	30	36	
2 1/2 x 1/4	1.667	2.083	14.7	U	22227	9879	5557	3556	2470
				Du	0.008	0.019	0.033	0.052	0.075
				C	11113	7409	5557	4445	3704
				Dc	0.007	0.015	0.027	0.041	0.060
2 1/2 x 3/8	2.5	3.125	21.5	U	33333	14815	8333	5333	3704
				Du	0.008	0.019	0.033	0.052	0.075
				C	16667	11111	8333	6667	5556
				Dc	0.007	0.015	0.027	0.041	0.060
3 x 1/4	2.4	3.6	17.4	U	32000	14222	8000	5120	3556
				Du	0.007	0.016	0.028	0.043	0.062
				C	16000	10667	8000	6400	5333
				Dc	0.006	0.012	0.022	0.035	0.050
3 x 3/8	3.6	5.4	25.6	U	48000	21333	12000	7680	5333
				Du	0.007	0.016	0.028	0.043	0.062
				C	24000	16000	12000	9600	8000
				Dc	0.006	0.012	0.022	0.035	0.050
3 1/2 x 1/4	3.267	5.717	20.2	U	43560	19360	10890	6970	4840
				Du	0.006	0.013	0.024	0.037	0.053
				C	21780	14520	10890	8712	7260
				Dc	0.005	0.011	0.019	0.030	0.043
3 1/2 x 3/8	4.9	8.575	29.7	U	65333	29037	16333	10453	7259
				Du	0.006	0.013	0.024	0.037	0.053
				C	32667	21778	16333	13067	10889
				Dc	0.005	0.011	0.019	0.030	0.043
4 x 1/4	4.267	8.533	22.9	U	56893	25286	14223	9103	6321
				Du	0.005	0.012	0.021	0.032	0.047
				C	28447	18964	14223	11379	9482
				Dc	0.004	0.009	0.017	0.026	0.037
4 x 3/8	6.4	12.800	33.8	U	85333	37926	21333	13653	9481
				Du	0.005	0.012	0.021	0.032	0.047
				C	42667	28444	21333	17067	14222
				Dc	0.004	0.009	0.017	0.026	0.037
4 1/2 x 1/4	5.4	12.15	25.6	U	72000	32000	18000	11520	8000
				Du	0.005	0.010	0.018	0.029	0.041
				C	36000	24000	18000	14400	12000
				Dc	0.004	0.008	0.015	0.023	0.033
4 1/2 x 3/8	8.1	18.225	37.8	U	108000	48000	27000	17280	12000
				Du	0.005	0.010	0.018	0.029	0.041
				C	54000	36000	27000	21600	18000
				Dc	0.004	0.008	0.015	0.023	0.033
5 x 1/4	6.667	16.667	28.3	U	88893	39508	22223	14223	9877
				Du	0.004	0.009	0.017	0.026	0.037
				C	44447	29631	22223	17779	14816
				Dc	0.003	0.007	0.013	0.021	0.030
5 x 3/8	10	25	41.9	U	133333	59259	33333	21333	14815
				Du	0.004	0.009	0.017	0.026	0.037
				C	66667	44444	33333	26667	22222
				Dc	0.003	0.007	0.013	0.021	0.030

NOTE: When serrated grating is specified, the depth of grating required for specific load will be the next depth greater than that shown in these tables.

Loads above DO NOT include the dead load of the grating.

**STATIC  
LOAD  
TABLES**

**(Chart begins on page 31)**

U—Uniform Load, Pounds per Square Foot		C—Concentrated Load, Pounds per Foot of Width						D—Deflection, Inches	
Span in Inches									
42	48	54	60	66	72	78	84	90	96
1814	1389	1098	889	735	617	526	454	395	347
0.101	0.132	0.168	0.207	0.251	0.298	0.350	0.406	0.466	0.529
3175	2778	2470	2223	2021	1852	1710	1588	1482	1389
0.081	0.106	0.134	0.166	0.200	0.238	0.280	0.325	0.373	0.424
2721	2083	1646	1333	1102	926	789	680	593	521
0.101	0.132	0.168	0.207	0.250	0.298	0.350	0.405	0.466	0.530
4762	4167	3704	3333	3030	2778	2564	2381	2222	2083
0.081	0.106	0.134	0.166	0.200	0.238	0.280	0.324	0.372	0.424
2612	2000	1580	1280	1058	889	757	653	569	500
0.085	0.110	0.140	0.172	0.209	0.248	0.291	0.338	0.388	0.441
4571	4000	3556	3200	2909	2667	2462	2286	2133	2000
0.068	0.088	0.112	0.138	0.167	0.199	0.233	0.270	0.310	0.353
3918	3000	2370	1920	1587	1333	1136	980	853	750
0.085	0.110	0.140	0.172	0.209	0.248	0.291	0.338	0.388	0.441
6857	6000	5333	4800	4364	4000	3692	3429	3200	3000
0.068	0.088	0.112	0.138	0.167	0.199	0.233	0.270	0.310	0.353
3556	2723	2151	1742	1440	1210	1031	889	774	681
0.072	0.095	0.120	0.148	0.179	0.213	0.250	0.290	0.332	0.379
6223	5445	4840	4356	3960	3630	3351	3111	2904	2723
0.058	0.076	0.096	0.118	0.143	0.170	0.200	0.232	0.266	0.303
5333	4083	3226	2613	2160	1815	1546	1333	1161	1021
0.072	0.095	0.120	0.148	0.179	0.213	0.250	0.290	0.332	0.378
9333	8167	7259	6533	5939	5444	5026	4667	4356	4083
0.058	0.076	0.096	0.118	0.143	0.170	0.200	0.232	0.266	0.303
4644	3556	2810	2276	1881	1580	1347	1161	1011	889
0.063	0.083	0.105	0.129	0.157	0.186	0.219	0.254	0.291	0.331
8128	7112	6321	5689	5172	4741	4376	4064	3793	3556
0.051	0.066	0.084	0.104	0.125	0.149	0.175	0.203	0.233	0.265
6966	5333	4214	3413	2821	2370	2020	1741	1517	1333
0.063	0.083	0.105	0.129	0.157	0.186	0.219	0.253	0.291	0.331
12190	10667	9481	8533	7758	7111	6564	6095	5689	5333
0.051	0.066	0.084	0.103	0.125	0.149	0.175	0.203	0.233	0.265
5878	4500	3556	2880	2380	2000	1704	1469	1280	1125
0.056	0.074	0.093	0.115	0.139	0.166	0.194	0.225	0.259	0.294
10286	9000	8000	7200	6545	6000	5538	5143	4800	4500
0.045	0.059	0.075	0.092	0.111	0.132	0.155	0.180	0.207	0.235
8816	6750	5333	4320	3570	3000	2556	2204	1920	1688
0.056	0.074	0.093	0.115	0.139	0.166	0.194	0.225	0.259	0.294
15429	13500	12000	10800	9818	9000	8308	7714	7200	6750
0.045	0.059	0.075	0.092	0.111	0.132	0.155	0.180	0.207	0.235
7257	5556	4390	3556	2939	2469	2104	1814	1580	1389
0.051	0.066	0.084	0.104	0.125	0.149	0.175	0.203	0.233	0.265
12699	11112	9877	8889	8081	7408	6838	6350	5926	5556
0.041	0.053	0.067	0.083	0.100	0.119	0.140	0.162	0.186	0.212
10884	8333	6584	5333	4408	3704	3156	2721	2370	2083
0.051	0.066	0.084	0.103	0.125	0.149	0.175	0.203	0.233	0.265
19048	16667	14815	13333	12121	11111	10256	9524	8889	8333
0.041	0.053	0.067	0.083	0.100	0.119	0.140	0.162	0.186	0.212

\*Weight depends on panel width, cross bar selection, mill tolerance and manufacturing tolerance.

Loads above DO NOT include the dead load of the grating.



**STATIC  
LOAD  
TABLES**

**W-38-4 HEAVY DUTY WELDED STEEL GRATING**

(Chart continues on page 34)

No. Bars/Ft. of Width		5.053		Allowable Fiber Stress		20,000 psi			
U—Uniform Load, Pounds per Square Foot				C—Concentrated Load, Pounds per Foot of Width		D—Deflection, Inches			
Bearing Bar Size in.	Section Modulus in. <sup>3</sup> per. ft. of width	Moment Inertia in. <sup>4</sup>	Approx. Weight* lb/sqft	Span in Inches					
				12	18	24	30	36	
1 x 1/4	0.211	0.105	5.4	U	2813	1250	703	450	313
				Du	0.021	0.047	0.083	0.130	0.187
				C	1407	938	703	563	469
				Dc	0.017	0.037	0.067	0.104	0.150
1 x 3/8	0.316	0.158	7.6	U	4213	1873	1053	674	468
				Du	0.021	0.047	0.083	0.129	0.186
				C	2107	1404	1053	843	702
				Dc	0.017	0.037	0.066	0.104	0.149
1 1/4 x 1/4	0.329	0.206	6.5	U	4387	1950	1097	702	487
				Du	0.017	0.037	0.066	0.103	0.149
				C	2193	1462	1097	877	731
				Dc	0.013	0.030	0.053	0.083	0.119
1 1/4 x 3/8	0.493	0.308	9.2	U	6573	2921	1643	1052	730
				Du	0.017	0.037	0.066	0.104	0.149
				C	3287	2191	1643	1315	1096
				Dc	0.013	0.030	0.053	0.083	0.119
1 1/2 x 1/4	0.474	0.355	7.6	U	6320	2809	1580	1011	702
				Du	0.014	0.031	0.055	0.086	0.124
				C	3160	2107	1580	1264	1053
				Dc	0.011	0.025	0.044	0.069	0.099
1 1/2 x 3/8	0.711	0.533	10.8	U	9480	4213	2370	1517	1053
				Du	0.014	0.031	0.055	0.086	0.124
				C	4740	3160	2370	1896	1580
				Dc	0.011	0.025	0.044	0.069	0.099
1 3/4 x 1/4	0.645	0.564	8.6	U	8600	3822	2150	1376	956
				Du	0.012	0.027	0.047	0.074	0.107
				C	4300	2867	2150	1720	1433
				Dc	0.010	0.021	0.038	0.059	0.085
1 3/4 x 3/8	0.967	0.846	12.4	U	12893	5730	3223	2063	1433
				Du	0.012	0.027	0.047	0.074	0.106
				C	6447	4298	3223	2579	2149
				Dc	0.010	0.021	0.038	0.059	0.085
2 x 1/4	0.842	0.842	9.7	U	11227	4990	2807	1796	1247
				Du	0.010	0.023	0.041	0.065	0.093
				C	5613	3742	2807	2245	1871
				Dc	0.008	0.019	0.033	0.052	0.075
2 x 3/8	1.263	1.263	14.0	U	16840	7484	4210	2694	1871
				Du	0.010	0.023	0.041	0.065	0.093
				C	8420	5613	4210	3368	2807
				Dc	0.008	0.019	0.033	0.052	0.075
2 1/4 x 1/4	1.066	1.199	10.8	U	14213	6317	3553	2274	1579
				Du	0.009	0.021	0.037	0.058	0.083
				C	7107	4738	3553	2843	2369
				Dc	0.007	0.017	0.029	0.046	0.066
2 1/4 x 3/8	1.599	1.799	15.6	U	21320	9476	5330	3411	2369
				Du	0.009	0.021	0.037	0.058	0.083
				C	10660	7107	5330	4264	3553
				Dc	0.007	0.017	0.029	0.046	0.066

NOTE: When serrated grating is specified, the depth of grating required for specific load will be the next depth greater than that shown in these tables.

Loads above DO NOT include the dead load of the grating.

**STATIC  
LOAD  
TABLES**

**(Chart begins on page 33)**

U—Uniform Load, Pounds per Square Foot			C—Concentrated Load, Pounds per Foot of Width				D—Deflection, Inches			
Span in Inches										
42	48	54	60	66	72	78	84	90	96	
230	176	139	113	93	78	67	57	50	44	
0.255	0.333	0.421	0.522	0.629	0.747	0.884	1.011	1.169	1.332	
402	352	313	281	256	234	216	201	188	176	
0.204	0.266	0.337	0.415	0.504	0.598	0.701	0.815	0.938	1.065	
344	263	208	169	139	117	100	86	75	66	
0.254	0.331	0.419	0.519	0.625	0.745	0.877	1.014	1.165	1.328	
602	527	468	421	383	351	324	301	281	263	
0.203	0.265	0.335	0.414	0.501	0.596	0.699	0.811	0.931	1.058	
358	274	217	175	145	122	104	90	78	69	
0.202	0.264	0.335	0.412	0.500	0.596	0.699	0.814	0.930	1.065	
627	548	487	439	399	366	337	313	292	274	
0.162	0.211	0.267	0.331	0.400	0.476	0.558	0.647	0.742	0.845	
537	411	325	263	217	183	156	134	117	103	
0.203	0.265	0.336	0.414	0.500	0.597	0.702	0.811	0.933	1.063	
939	822	730	657	598	548	506	470	438	411	
0.162	0.212	0.268	0.331	0.401	0.477	0.560	0.650	0.745	0.848	
516	395	312	253	209	176	150	129	112	99	
0.169	0.221	0.280	0.346	0.418	0.499	0.585	0.677	0.775	0.886	
903	790	702	632	575	527	486	451	421	395	
0.135	0.177	0.224	0.276	0.335	0.398	0.467	0.541	0.621	0.707	
774	593	468	379	313	263	224	193	169	148	
0.169	0.221	0.279	0.345	0.417	0.496	0.582	0.675	0.778	0.882	
1354	1185	1053	948	862	790	729	677	632	593	
0.135	0.177	0.224	0.276	0.334	0.397	0.466	0.541	0.621	0.707	
702	538	425	344	284	239	204	176	153	134	
0.145	0.190	0.240	0.296	0.358	0.426	0.501	0.581	0.666	0.755	
1229	1075	956	860	782	717	662	614	573	538	
0.116	0.151	0.192	0.237	0.286	0.341	0.400	0.464	0.532	0.606	
1053	806	637	516	426	358	305	263	229	201	
0.145	0.189	0.240	0.296	0.358	0.426	0.499	0.579	0.665	0.755	
1842	1612	1433	1289	1172	1074	992	921	860	806	
0.116	0.151	0.192	0.236	0.286	0.340	0.400	0.464	0.532	0.606	
916	702	554	449	371	312	266	229	200	175	
0.127	0.166	0.209	0.259	0.313	0.373	0.438	0.507	0.583	0.661	
1604	1403	1247	1123	1021	936	864	802	748	702	
0.101	0.132	0.168	0.207	0.250	0.298	0.350	0.406	0.465	0.530	
1375	1053	832	674	557	468	399	344	299	263	
0.127	0.166	0.210	0.259	0.313	0.373	0.438	0.507	0.581	0.662	
2406	2105	1871	1684	1531	1403	1295	1203	1123	1053	
0.101	0.132	0.168	0.207	0.250	0.298	0.350	0.406	0.466	0.530	
1160	888	702	569	470	395	336	290	253	222	
0.113	0.147	0.186	0.230	0.278	0.331	0.388	0.451	0.518	0.588	
2030	1777	1579	1421	1292	1184	1093	1015	948	888	
0.090	0.118	0.149	0.184	0.223	0.265	0.311	0.361	0.414	0.471	
1740	1333	1053	853	705	592	505	435	379	333	
0.113	0.147	0.186	0.230	0.278	0.331	0.389	0.450	0.517	0.588	
3046	2665	2369	2132	1938	1777	1640	1523	1421	1333	
0.090	0.118	0.149	0.184	0.223	0.265	0.311	0.361	0.414	0.471	

\*Weight depends on panel width, cross bar selection, mill tolerance and manufacturing tolerance.

Loads above DO NOT include the dead load of the grating.

**STATIC  
LOAD  
TABLES**

**W-38-4 HEAVY DUTY WELDED STEEL GRATING (Con't.)** (Chart continues on page 36)

No. Bars/Ft. of Width		5.053		Allowable Fiber Stress		20,000 psi			
U—Uniform Load, Pounds per Square Foot				C—Concentrated Load, Pounds per Foot of Width		D—Deflection, Inches			
Bearing Bar Size in.	Section Modulus in. <sup>3</sup> per ft. of width	Moment Inertia in. <sup>4</sup>	Approx. Weight* lb/sqft	Span in Inches					
					12	18	24	30	36
2 1/2 x 1/4	1.316	1.645	11.9	U	17547	7799	4387	2807	1950
				Du	0.008	0.019	0.033	0.052	0.075
				C	8773	5849	4387	3509	2924
				Dc	0.007	0.015	0.027	0.041	0.060
2 1/2 x 3/8	1.974	2.467	17.2	U	26320	11698	6580	4211	2924
				Du	0.008	0.019	0.033	0.052	0.075
				C	13160	8773	6580	5264	4387
				Dc	0.007	0.015	0.027	0.041	0.060
3 x 1/4	1.895	2.842	14.0	U	25267	11230	6317	4043	2807
				Du	0.007	0.016	0.028	0.043	0.062
				C	12633	8422	6317	5053	4211
				Dc	0.006	0.012	0.022	0.035	0.050
3 x 3/8	2.842	4.263	20.5	U	37893	16841	9473	6063	4210
				Du	0.007	0.016	0.028	0.043	0.062
				C	18947	12631	9473	7579	6316
				Dc	0.006	0.012	0.022	0.035	0.050
3 1/2 x 1/4	2.579	4.513	16.2	U	34387	15283	8597	5502	3821
				Du	0.006	0.013	0.024	0.037	0.053
				C	17193	11462	8597	6877	5731
				Dc	0.005	0.011	0.019	0.030	0.043
3 1/2 x 3/8	3.869	6.77	23.7	U	51587	22927	12897	8254	5732
				Du	0.006	0.013	0.024	0.037	0.053
				C	25793	17196	12897	10317	8598
				Dc	0.005	0.011	0.019	0.030	0.043
4 x 1/4	3.369	6.737	18.3	U	44920	19964	11230	7187	4991
				Du	0.005	0.012	0.021	0.032	0.047
				C	22460	14973	11230	8984	7487
				Dc	0.004	0.009	0.017	0.026	0.037
4 x 3/8	5.053	10.106	26.9	U	67373	29944	16843	10780	7486
				Du	0.005	0.012	0.021	0.032	0.047
				C	33687	22458	16843	13475	11229
				Dc	0.004	0.009	0.017	0.026	0.037
4 1/2 x 1/4	4.263	9.593	20.5	U	56840	25262	14210	9094	6316
				Du	0.005	0.010	0.018	0.029	0.041
				C	28420	18947	14210	11368	9473
				Dc	0.004	0.008	0.015	0.023	0.033
4 1/2 x 3/8	6.395	14.389	30.1	U	85267	37896	21317	13643	9474
				Du	0.005	0.010	0.018	0.029	0.041
				C	42633	28422	21317	17053	14211
				Dc	0.004	0.008	0.015	0.023	0.033
5 x 1/4	5.264	13.159	22.6	U	70187	31194	17547	11230	7799
				Du	0.004	0.009	0.017	0.026	0.037
				C	35093	23396	17547	14037	11698
				Dc	0.003	0.007	0.013	0.021	0.030
5 x 3/8	7.895	19.738	33.3	U	105267	46785	26317	16843	11696
				Du	0.004	0.009	0.017	0.026	0.037
				C	52633	35089	26317	21053	17544
				Dc	0.003	0.007	0.013	0.021	0.030

NOTE: When serrated grating is specified, the depth of grating required for specific load will be the next depth greater than that shown in these tables.

Loads above DO NOT include the dead load of the grating.

**STATIC  
LOAD  
TABLES**

**(Chart begins on page 35)**

U—Uniform Load, Pounds per Square Foot		C—Concentrated Load, Pounds per Foot of Width						D—Deflection, Inches	
Span in Inches									
42	48	54	60	66	72	78	84	90	96
1432	1097	867	702	580	487	415	358	312	274
0.101	0.133	0.168	0.207	0.250	0.298	0.349	0.405	0.466	0.529
2507	2193	1950	1755	1595	1462	1350	1253	1170	1097
0.081	0.106	0.134	0.166	0.200	0.238	0.280	0.324	0.373	0.424
2149	1645	1300	1053	870	731	623	537	468	411
0.101	0.132	0.168	0.207	0.250	0.298	0.350	0.406	0.466	0.529
3760	3290	2924	2632	2393	2193	2025	1880	1755	1645
0.081	0.106	0.134	0.166	0.200	0.238	0.280	0.325	0.373	0.424
2063	1579	1248	1011	835	702	598	516	449	395
0.085	0.110	0.140	0.173	0.209	0.248	0.291	0.338	0.388	0.442
3610	3158	2807	2527	2297	2106	1944	1805	1684	1579
0.068	0.088	0.112	0.138	0.167	0.199	0.233	0.270	0.310	0.353
3093	2368	1871	1516	1253	1053	897	773	674	592
0.085	0.110	0.140	0.172	0.209	0.248	0.291	0.338	0.388	0.441
5413	4737	4210	3789	3445	3158	2915	2707	2526	2368
0.068	0.088	0.112	0.138	0.167	0.199	0.233	0.270	0.310	0.353
2807	2149	1698	1375	1137	955	814	702	611	537
0.072	0.095	0.120	0.148	0.179	0.213	0.250	0.290	0.332	0.378
4912	4298	3821	3439	3126	2866	2645	2456	2292	2149
0.058	0.076	0.096	0.118	0.143	0.170	0.200	0.232	0.266	0.303
4211	3224	2547	2063	1705	1433	1221	1053	917	806
0.072	0.095	0.120	0.148	0.179	0.213	0.250	0.290	0.333	0.378
7370	6448	5732	5159	4690	4299	3968	3685	3439	3224
0.058	0.076	0.096	0.118	0.143	0.170	0.200	0.232	0.266	0.303
3667	2808	2218	1797	1485	1248	1063	917	799	702
0.063	0.083	0.105	0.129	0.157	0.186	0.219	0.254	0.291	0.331
6417	5615	4991	4492	4084	3743	3455	3209	2995	2808
0.051	0.066	0.084	0.104	0.125	0.149	0.175	0.203	0.233	0.265
5500	4211	3327	2695	2227	1871	1595	1375	1198	1053
0.063	0.083	0.105	0.129	0.157	0.186	0.219	0.254	0.291	0.331
9625	8422	7486	6737	6125	5614	5183	4812	4492	4211
0.051	0.066	0.084	0.103	0.125	0.149	0.175	0.203	0.233	0.265
4640	3553	2807	2274	1879	1579	1345	1160	1010	888
0.056	0.074	0.093	0.115	0.139	0.166	0.194	0.225	0.259	0.294
8120	7105	6316	5684	5167	4737	4372	4060	3789	3553
0.045	0.059	0.075	0.092	0.111	0.132	0.155	0.180	0.207	0.235
6961	5329	4211	3411	2819	2369	2018	1740	1516	1332
0.056	0.074	0.093	0.115	0.139	0.166	0.194	0.225	0.259	0.294
12181	10658	9474	8527	7752	7106	6559	6090	5684	5329
0.045	0.059	0.075	0.092	0.111	0.132	0.155	0.180	0.207	0.235
5730	4387	3466	2807	2320	1950	1661	1432	1248	1097
0.051	0.066	0.084	0.103	0.125	0.149	0.175	0.203	0.233	0.265
10027	8773	7799	7019	6381	5849	5399	5013	4679	4387
0.041	0.053	0.067	0.083	0.100	0.119	0.140	0.162	0.186	0.212
8593	6579	5198	4211	3480	2924	2492	2148	1871	1645
0.051	0.066	0.084	0.104	0.125	0.149	0.175	0.203	0.233	0.265
15038	13158	11696	10527	9570	8772	8097	7519	7018	6579
0.041	0.053	0.067	0.083	0.100	0.119	0.140	0.162	0.186	0.212

\*Weight depends on panel width, cross bar selection, mill tolerance and manufacturing tolerance.

Loads above DO NOT include the dead load of the grating.



**STATIC  
LOAD  
TABLES**

**R-37-5 HEAVY DUTY RIVETED STEEL GRATING**

(Chart continues on page 38)

No. of Bearing bars/ Ft of Width = No. of Connecting bars/ Ft of Width = 4.683 for b = 1/4"		No. of Bearing bars/ Ft of Width = No. of Connecting bars/ Ft of Width = 4.465 for b = 3/8"		Allowable Fiber Stress		20,000 psi			
U—Uniform Load, Pounds per Square Foot			C—Concentrated Load, Pounds per Foot of Width			D—Deflection, Inches			
Bearing Bar Size in.	Section Modulus in. <sup>3</sup> per. ft. of width	Moment Inertia in. <sup>4</sup>	Approx. Weight* lb/sqft	Span in Inches					
					12	18	24	30	36
2 x 1/4	0.991	1.080	14.63	U	13,213	5,873	3,303	2,114	1,468
				Du	0.009	0.021	0.038	0.059	0.085
				C	6,607	4,404	3,303	2,643	2,202
				Dc	0.008	0.017	0.030	0.047	0.068
2 x 3/8	1.319	1.409	17.91	U	17,585	7,815	4,396	2,814	1,954
				Du	0.010	0.022	0.039	0.061	0.087
				C	8,792	5,862	4,396	3,517	2,931
				Dc	0.008	0.017	0.031	0.048	0.070
2 1/4 x 1/4	1.185	1.482	15.68	U	15,805	7,025	3,951	2,529	1,756
				Du	0.008	0.019	0.033	0.052	0.074
				C	7,903	5,268	3,951	3,161	2,634
				Dc	0.007	0.015	0.026	0.041	0.060
2 1/4 x 3/8	1.606	1.957	19.41	U	21,412	9,516	5,353	3,426	2,379
				Du	0.008	0.019	0.034	0.053	0.076
				C	10,706	7,137	5,353	4,282	3,569
				Dc	0.007	0.015	0.027	0.042	0.061
2 1/2 x 1/4	1.422	1.999	17.02	U	18,963	8,428	4,741	3,034	2,107
				Du	0.007	0.017	0.029	0.046	0.066
				C	9,481	6,321	4,741	3,793	3,160
				Dc	0.006	0.013	0.024	0.037	0.053
2 1/2 x 3/8	1.946	2.657	20.84	U	25,948	11,532	6,487	4,152	2,883
				Du	0.008	0.017	0.030	0.047	0.068
				C	12,974	8,649	6,487	5,190	4,325
				Dc	0.006	0.014	0.024	0.038	0.055
3 x 1/4	2.006	3.420	19.27	U	26,747	11,887	6,687	4,279	2,972
				Du	0.006	0.014	0.024	0.038	0.055
				C	13,373	8,916	6,687	5,349	4,458
				Dc	0.005	0.011	0.019	0.030	0.044
3 x 3/8	2.769	4.568	23.96	U	36,913	16,406	9,228	5,906	4,101
				Du	0.006	0.014	0.025	0.039	0.056
				C	18,457	12,304	9,228	7,383	6,152
				Dc	0.005	0.011	0.020	0.031	0.045
3 1/2 x 1/4	2.723	5.427	21.52	U	36,303	16,135	9,076	5,808	4,034
				Du	0.005	0.012	0.021	0.032	0.047
				C	18,151	12,101	9,076	7,261	6,050
				Dc	0.004	0.009	0.017	0.026	0.037
3 1/2 x 3/8	3.764	7.252	27.09	U	50,192	22,308	12,548	8,031	5,577
				Du	0.005	0.012	0.021	0.034	0.048
				C	25,096	16,731	12,548	10,038	8,365
				Dc	0.004	0.010	0.017	0.027	0.039

NOTE: When serrated grating is specified, the depth of grating required for a specific load will be the next greater depth than that shown in these tables.

Loads above DO NOT include the dead load of the grating.



(Chart begins on page 37)

U—Uniform Load, Pounds per Square Foot			C—Concentrated Load, Pounds per Foot of Width			D—Deflection, Inches		
Span in Inches								
42	48	54	60	66	72	78	84	96
1,079	826	653	529	437	367	313	270	206
0.116	0.152	0.192	0.237	0.287	0.342	0.401	0.465	0.607
1,888	1,652	1,468	1,321	1,201	1,101	1,016	944	826
0.093	0.121	0.154	0.190	0.230	0.273	0.321	0.372	0.486
1,435	1,099	868	703	581	488	416	359	275
0.119	0.155	0.196	0.242	0.293	0.349	0.409	0.475	0.620
2,512	2,198	1,954	1,758	1,599	1,465	1,353	1,256	1,099
0.095	0.124	0.157	0.194	0.234	0.279	0.327	0.380	0.496
1,290	988	781	632	522	439	374	323	247
0.101	0.132	0.168	0.207	0.250	0.298	0.350	0.406	0.530
2,258	1,976	1,756	1,581	1,437	1,317	1,216	1,129	988
0.081	0.106	0.134	0.166	0.200	0.238	0.280	0.324	0.424
1,748	1,338	1,057	856	708	595	507	437	335
0.104	0.136	0.172	0.212	0.257	0.306	0.359	0.416	0.543
3,059	2,677	2,379	2,141	1,947	1,784	1,647	1,529	1,338
0.083	0.109	0.137	0.170	0.205	0.244	0.287	0.333	0.435
1,548	1,185	936	759	627	527	449	387	296
0.090	0.118	0.149	0.184	0.223	0.265	0.311	0.361	0.471
2,709	2,370	2,107	1,896	1,724	1,580	1,459	1,354	1,185
0.072	0.094	0.119	0.147	0.178	0.212	0.249	0.289	0.377
2,118	1,622	1,281	1,038	858	721	614	530	405
0.093	0.121	0.153	0.189	0.229	0.273	0.320	0.371	0.485
3,707	3,244	2,883	2,595	2,359	2,162	1,996	1,853	1,622
0.074	0.097	0.123	0.152	0.183	0.218	0.256	0.297	0.388
2,183	1,672	1,321	1,070	884	743	633	546	418
0.074	0.097	0.123	0.152	0.184	0.218	0.256	0.297	0.388
3,821	3,343	2,972	2,675	2,432	2,229	2,057	1,910	1,672
0.059	0.078	0.098	0.121	0.147	0.175	0.205	0.238	0.311
3,013	2,307	1,823	1,477	1,220	1,025	874	753	577
0.077	0.100	0.127	0.157	0.190	0.226	0.265	0.307	0.401
5,273	4,614	4,101	3,691	3,356	3,076	2,839	2,637	2,307
0.061	0.080	0.102	0.125	0.152	0.181	0.212	0.246	0.321
2,963	2,269	1,793	1,452	1,200	1,008	859	741	567
0.064	0.083	0.105	0.130	0.157	0.187	0.219	0.254	0.332
5,186	4,538	4,034	3,630	3,300	3,025	2,793	2,593	2,269
0.051	0.066	0.084	0.104	0.126	0.149	0.175	0.203	0.266
4,097	3,137	2,479	2,008	1,659	1,394	1,188	1,024	784
0.066	0.086	0.109	0.134	0.162	0.193	0.227	0.263	0.344
7,170	6,274	5,577	5,019	4,563	4,183	3,861	3,585	3,137
0.053	0.069	0.087	0.107	0.130	0.155	0.181	0.210	0.275

Loads above DO NOT include the dead load of the grating.

**STATIC  
LOAD  
TABLES**

**R-37-5 HEAVY DUTY RIVETED STEEL GRATING (con't.)****(Chart continues on page 40)**

No. of Bearing bars/ Ft of Width = No. of Connecting bars/ Ft of Width = 4.683 for b = 1/4"				Allowable Fiber Stress		20,000 psi			
No. of Bearing bars/ Ft of Width = No. of Connecting bars/ Ft of Width = 4.465 for b = 3/8"									
U—Uniform Load, Pounds per Square Foot			C—Concentrated Load, Pounds per Foot of Width			D—Deflection, Inches			
Bearing Bar Size in.	Section Modulus in. <sup>3</sup> per. ft. of width	Moment Inertia in. <sup>4</sup>	Approx. Weight* lb/sqft	Span in Inches					
					12	18	24	30	36
4 x 1/4	3.560	8.097	23.78	U	47,469	21,097	11,867	7,595	5,274
				Du	0.005	0.010	0.018	0.028	0.041
				C	23,735	15,823	11,867	9,494	7,912
				Dc	0.004	0.008	0.015	0.023	0.033
4 x 3/8	4.923	10.818	30.21	U	65,641	29,174	16,410	10,503	7,293
				Du	0.005	0.011	0.019	0.029	0.042
				C	32,821	21,880	16,410	13,128	10,940
				Dc	0.004	0.008	0.015	0.024	0.034
4 1/2 x 1/4	4.513	11.508	26.03	U	60,175	26,744	15,044	9,628	6,686
				Du	0.004	0.009	0.016	0.025	0.037
				C	30,087	20,058	15,044	12,035	10,029
				Dc	0.003	0.007	0.013	0.020	0.029
4 1/2 x 3/8	6.238	15.372	33.34	U	83,173	36,966	20,793	13,308	9,241
				Du	0.004	0.009	0.017	0.026	0.038
				C	41,587	27,724	20,793	16,635	13,862
				Dc	0.003	0.008	0.013	0.021	0.030
5 x 1/4	5.577	15.735	28.28	U	74,361	33,049	18,590	11,898	8,262
				Du	0.004	0.008	0.015	0.023	0.033
				C	37,181	24,787	18,590	14,872	12,394
				Dc	0.003	0.007	0.012	0.018	0.026
5 x 3/8	7.705	21.021	36.46	U	102,732	45,659	25,683	16,437	11,415
				Du	0.004	0.009	0.015	0.024	0.034
				C	51,366	34,244	25,683	20,546	17,122
				Dc	0.003	0.007	0.012	0.019	0.027

NOTE: When serrated grating is specified, the depth of grating required for a specific load will be the next greater depth than that shown in these tables.

Loads above DO NOT include the dead load of the grating.

**STATIC  
LOAD  
TABLES**

**(Chart begins on page 39)**

U—Uniform Load, Pounds per Square Foot			C—Concentrated Load, Pounds per Foot of Width				D—Deflection, Inches	
Span in Inches								
42	48	54	60	66	72	78	84	96
3,875	2,967	2,344	1,899	1,569	1,319	1,124	969	742
0.056	0.073	0.092	0.114	0.138	0.164	0.192	0.223	0.291
6,781	5,934	5,274	4,747	4,315	3,956	3,651	3,391	2,967
0.045	0.058	0.074	0.091	0.110	0.131	0.154	0.178	0.233
5,358	4,103	3,242	2,626	2,170	1,823	1,554	1,340	1,026
0.058	0.075	0.095	0.118	0.142	0.169	0.199	0.231	0.301
9,377	8,205	7,293	6,564	5,967	5,470	5,049	4,689	4,103
0.046	0.060	0.076	0.094	0.114	0.136	0.159	0.185	0.241
4,912	3,761	2,972	2,407	1,989	1,672	1,424	1,228	940
0.050	0.065	0.082	0.101	0.123	0.146	0.171	0.199	0.260
8,596	7,522	6,686	6,017	5,470	5,015	4,629	4,298	3,761
0.040	0.052	0.066	0.081	0.098	0.117	0.137	0.159	0.208
6,790	5,198	4,107	3,327	2,750	2,310	1,969	1,697	1,300
0.051	0.067	0.085	0.105	0.127	0.151	0.177	0.206	0.269
11,882	10,397	9,241	8,317	7,561	6,931	6,398	5,941	5,198
0.041	0.054	0.068	0.084	0.102	0.121	0.142	0.165	0.215
6,070	4,648	3,672	2,974	2,458	2,066	1,760	1,518	1,162
0.045	0.059	0.074	0.092	0.111	0.132	0.155	0.180	0.235
10,623	9,295	8,262	7,436	6,760	6,197	5,720	5,312	4,648
0.036	0.047	0.059	0.073	0.089	0.106	0.124	0.144	0.188
8,386	6,421	5,073	4,109	3,396	2,854	2,432	2,097	1,605
0.046	0.061	0.077	0.095	0.115	0.136	0.160	0.186	0.243
14,676	12,842	11,415	10,273	9,339	8,561	7,902	7,338	6,421
0.037	0.049	0.061	0.076	0.092	0.109	0.128	0.149	0.194

Loads above DO NOT include the dead load of the grating.

**STATIC  
LOAD  
TABLES  
(METRIC)**

**W-19-4 HEAVY DUTY WELDED STEEL GRATING****(Chart continues on page 42)**

No. Bars/Ft. of Width		10.10	Allowable Fiber Stress		137.9 MPa				
No. Bars/Meter of Width		33.15							
U—Uniform Load, kPa			C—Concentrated Load, N/mm of width				D—Deflection, mm		
Bearing Bar Size mm (inches)	Section Modulus per. ft.(304.8mm) width	Moment Inertia	Approx. Wt*(Kg)/ Sq. meter	Span in Millimeters					
					305	457	610	762	914
25 x 6.4 (1 x 1/4)	6 900	87 600	47	U	268	120	67	43	30
				Du	0.53	1.19	2.10	3.28	4.74
				C	41	27	20	16	14
				Dc	0.42	0.93	1.64	2.57	3.87
25 x 9.5 (1 x 3/8)	10 350	131 400	68	U	403	179	101	65	45
				Du	0.53	1.18	2.11	3.31	4.74
				C	61	41	31	25	20
				Dc	0.42	0.95	1.70	2.67	3.69
32 x 6.4 (1 1/4 x 1/4)	10 780	171 100	58	U	419	187	105	67	47
				Du	0.42	0.95	1.69	2.62	3.80
				C	64	43	32	26	21
				Dc	0.34	0.76	1.35	2.13	2.97
32 x 9.5 (1 1/4 x 3/8)	16 170	256 700	84	U	629	280	157	101	70
				Du	0.42	0.94	1.68	2.63	3.78
				C	96	64	48	38	32
				Dc	0.34	0.76	1.35	2.08	3.02
38 x 6.4 (1 1/2 x 1/4)	15 520	295 700	68	U	604	269	151	97	67
				Du	0.35	0.79	1.40	2.19	3.14
				C	92	61	46	37	31
				Dc	0.28	0.63	1.12	1.76	2.54
38 x 9.5 (1 1/2 x 3/8)	23 300	443 600	100	U	906	404	227	145	101
				Du	0.35	0.79	1.41	2.19	3.15
				C	138	92	69	55	46
				Dc	0.28	0.63	1.12	1.74	2.51
44 x 6.4 (1 3/4 x 1/4)	21 100	469 600	79	U	822	366	206	132	92
				Du	0.30	0.67	1.21	1.88	2.71
				C	125	84	63	50	42
				Dc	0.24	0.54	0.97	1.50	2.17
44 x 9.5 (1 3/4 x 3/8)	31 700	704 400	116	U	1233	549	308	198	137
				Du	0.30	0.67	1.20	1.88	2.69
				C	188	126	94	75	63
				Dc	0.24	0.54	0.96	1.50	2.17
51 x 6.4 (2 x 1/4)	27 600	701 000	89	U	1074	478	268	172	120
				Du	0.26	0.59	1.05	1.64	2.37
				C	164	109	82	66	55
				Dc	0.21	0.47	0.84	1.32	1.90
51 x 9.5 (2 x 3/8)	41 400	1 051 500	131	U	1611	717	403	258	179
				Du	0.26	0.59	1.05	1.64	2.36
				C	246	164	123	98	82
				Dc	0.21	0.47	0.84	1.31	1.89
57 x 6.4 (2 1/4 x 1/4)	34 900	998 100	100	U	1359	605	340	218	151
				Du	0.23	0.52	0.94	1.46	2.10
				C	207	138	104	83	69
				Dc	0.19	0.42	0.75	1.17	1.68
57 x 9.5 (2 1/4 x 3/8)	52 400	1 497 200	147	U	2039	908	510	327	227
				Du	0.23	0.52	0.94	1.46	2.10
				C	311	207	155	124	104
				Dc	0.19	0.42	0.75	1.16	1.68

NOTE: When serrated grating is specified, the depth of grating required for specific load will be the next depth greater than that shown in these tables.

Loads above DO NOT include the dead load of the grating.

**STATIC  
LOAD  
TABLES  
(METRIC)**

**(Chart begins on page 41)**

U—Uniform Load, kPa			C—Concentrated Load, N/mm of Width				D—Deflection,mm		
Span in Millimeters									
1067	1219	1372	1524	1676	1829	1981	2134	2286	2438
22	17	13	11	9	7	6	5	5	4
6.46	8.50	10.43	13.44	16.08	17.74	20.93	23.48	30.92	32.00
12	10	9	8	7	7	6	6	5	5
5.28	6.56	8.42	10.26	11.94	15.52	16.90	21.13	21.64	26.25
33	25	20	16	13	11	10	8	7	6
6.46	8.33	10.70	13.03	15.49	18.58	23.25	25.05	28.86	32.00
18	15	14	12	11	10	9	9	8	8
5.28	6.56	8.73	10.26	12.51	14.78	16.90	21.13	23.09	28.00
34	26	21	17	14	12	10	9	7	7
5.11	6.66	8.63	10.63	12.81	15.57	17.86	21.64	22.16	28.67
18	16	14	13	12	11	10	9	9	8
4.06	5.38	6.71	8.54	10.48	12.49	14.42	16.23	19.95	21.51
51	39	31	25	21	17	15	13	11	10
5.11	6.66	8.49	10.42	12.81	14.71	17.86	20.84	23.22	27.31
27	24	21	19	17	16	15	14	13	12
4.06	5.38	6.71	8.32	9.90	12.11	14.42	16.83	19.21	21.51
49	38	30	24	20	17	14	12	11	9
4.26	5.63	7.13	8.69	10.59	12.77	14.47	16.70	20.16	21.34
26	23	20	18	17	15	14	13	12	12
3.39	4.47	5.55	6.84	8.59	9.85	11.68	13.56	15.39	18.67
74	57	45	36	30	25	21	19	16	14
4.29	5.63	7.13	8.69	10.59	12.51	14.47	17.63	19.55	22.13
39	35	31	28	25	23	21	20	18	17
3.39	4.54	5.73	7.09	8.42	10.07	11.68	13.91	15.39	17.63
67	51	41	33	27	23	19	17	15	13
3.67	4.76	6.14	7.52	9.00	10.88	12.36	14.90	17.31	19.41
36	31	28	25	23	21	19	18	17	16
2.96	3.80	4.89	5.98	7.32	8.69	9.99	11.83	13.73	15.68
101	77	61	49	41	34	29	25	22	19
3.69	4.79	6.09	7.45	9.11	10.72	12.58	14.61	16.92	18.91
54	47	42	38	34	31	29	27	25	24
2.96	3.84	4.89	6.06	7.21	8.55	10.16	11.83	13.46	15.68
88	67	53	43	36	30	25	22	19	17
3.23	4.19	5.32	6.57	8.04	9.50	10.90	12.92	14.69	17.00
47	41	36	33	30	27	25	23	22	20
2.59	3.36	4.21	5.29	6.40	7.48	8.80	10.12	11.90	13.13
132	101	80	65	53	45	38	33	29	25
3.23	4.21	5.35	6.62	7.89	9.50	11.04	12.92	14.95	16.67
70	61	55	49	45	41	38	35	33	31
2.57	3.34	4.29	5.24	6.40	7.57	8.92	10.27	11.90	13.56
111	85	67	54	45	38	32	28	24	21
2.86	3.73	4.72	5.79	7.06	8.45	9.80	11.54	13.03	14.75
59	52	46	41	38	35	32	30	28	26
2.28	3.00	3.78	4.62	5.69	6.81	7.91	9.27	10.64	11.99
167	128	101	82	68	57	48	42	36	32
2.87	3.75	4.74	5.86	7.11	8.45	9.80	11.54	13.03	14.98
89	78	69	62	57	52	48	44	41	39
2.29	3.00	3.78	4.65	5.69	6.75	7.91	9.07	10.39	11.99

\*Weight depends on panel width, cross bar selection, mill tolerance and manufacturing tolerance.

Loads above DO NOT include the dead load of the grating.



**W-19-4 HEAVY DUTY WELDED STEEL GRATING (con't.) (Chart continues on page 44)**

No. Bars/Ft. of Width		10.10		Allowable Fiber Stress		137.9 MPa					
No. Bars/Meter of Width		33.15									
U—Uniform Load, kPa				C—Concentrated Load, N/mm of width				D—Deflection,mm			
Bearing Bar Size mm (inches)	Section Modulus per. ft.(304.8mm) width	Moment Inertia	Approx. Wt*(Kg)/Sq. meter	Span in Millimeters							
					305	457	610	762	914		
64 x 6.4 (2½ x ¼)	43 100	1 369 000	110	U	1678	747	419	269	187		
				Du	0.21	0.47	0.84	1.31	1.89		
				C	256	171	128	102	85		
				Dc	0.17	0.38	0.67	1.05	1.51		
64 x 9.5 (2½ x ⅜)	64 700	2 054 000	163	U	2517	1121	629	403	280		
				Du	0.21	0.47	0.84	1.31	1.89		
				C	384	256	192	154	128		
				Dc	0.17	0.38	0.67	1.05	1.51		
76 x 6.4 (3 x ¼)	62 100	2 366 000	131	U	2416	1076	604	387	269		
				Du	0.18	0.39	0.70	1.09	1.57		
				C	368	246	184	147	123		
				Dc	0.14	0.32	0.56	0.87	1.26		
76 x 9.5 (3 x ⅜)	93 100	3 549 000	194	U	3624	1614	906	581	404		
				Du	0.18	0.39	0.70	1.10	1.58		
				C	553	369	276	221	184		
				Dc	0.14	0.32	0.56	0.87	1.26		
89 x 6.4 (3½ x ¼)	84 500	3 757 000	152	U	3289	1465	822	527	366		
				Du	0.15	0.34	0.60	0.94	1.35		
				C	502	335	251	201	167		
				Dc	0.12	0.27	0.48	0.75	1.08		
89 x 9.5 (3½ x ⅜)	126 800	5 635 000	226	U	4933	2197	1233	790	549		
				Du	0.15	0.34	0.60	0.94	1.35		
				C	752	502	376	301	251		
				Dc	0.12	0.27	0.48	0.75	1.08		
102 x 6.4 (4 x ¼)	110 400	5 608 000	173	U	4295	1913	1074	688	478		
				Du	0.13	0.30	0.53	0.82	1.18		
				C	655	437	328	262	219		
				Dc	0.11	0.24	0.42	0.66	0.95		
102 x 9.5 (4 x ⅜)	165 600	8 412 000	257	U	6443	2870	1611	1032	717		
				Du	0.13	0.30	0.53	0.82	1.18		
				C	983	656	491	393	328		
				Dc	0.11	0.24	0.42	0.66	0.95		
114 x 6.4 (4½ x ¼)	139 700	7 985 000	194	U	5436	2421	1359	871	605		
				Du	0.12	0.26	0.47	0.73	1.05		
				C	829	553	415	332	277		
				Dc	0.09	0.21	0.37	0.58	0.84		
114 x 9.5 (4½ x ⅜)	209 600	11 977 000	288	U	8154	3632	2039	1306	908		
				Du	0.12	0.26	0.47	0.73	1.05		
				C	1244	830	622	498	415		
				Dc	0.09	0.21	0.37	0.58	0.84		
127 x 6.4 (5 x ¼)	172 500	10 953 000	215	U	6711	2989	1678	1075	747		
				Du	0.11	0.24	0.42	0.66	0.94		
				C	1023	683	512	410	342		
				Dc	0.08	0.19	0.34	0.53	0.76		
127 x 9.5 (5 x ⅜)	258 700	16 430 000	320	U	10067	4484	2517	1613	1121		
				Du	0.11	0.24	0.42	0.66	0.94		
				C	1535	1025	768	614	512		
				Dc	0.08	0.19	0.34	0.52	0.76		

NOTE: When serrated grating is specified, the depth of grating required for specific load will be the next depth greater than that shown in these tables.

Loads above DO NOT include the dead load of the grating.

**STATIC  
LOAD  
TABLES  
(METRIC)**

**(Chart begins on page 43)**

U—Uniform Load, kPa		C—Concentrated Load, N/mm of Width						D—Deflection,mm	
Span in Millimeters									
1067	1219	1372	1524	1676	1829	1981	2134	2286	2438
137	105	83	67	56	47	40	34	30	26
2.57	3.36	4.26	5.24	6.40	7.62	8.93	10.22	11.87	13.31
73	64	57	51	47	43	39	37	34	32
2.06	2.69	3.41	4.19	5.13	6.10	7.03	8.34	9.42	10.75
206	158	124	101	83	70	60	51	45	39
2.58	3.37	4.25	5.26	6.33	7.57	8.93	10.22	11.87	13.31
110	96	85	77	70	64	59	55	51	48
2.07	2.69	3.39	4.21	5.09	6.05	7.09	8.26	9.42	10.75
197	151	119	97	80	67	57	49	43	38
2.14	2.80	3.54	4.39	5.29	6.29	7.36	8.52	9.85	11.26
105	92	82	74	67	61	57	53	49	46
1.71	2.24	2.84	3.52	4.23	5.01	5.95	6.91	7.86	8.95
296	227	179	145	120	101	86	74	65	57
2.15	2.80	3.55	4.37	5.29	6.32	7.41	8.58	9.93	11.26
158	138	123	111	101	92	85	79	74	69
1.72	2.24	2.84	3.52	4.25	5.04	5.91	6.87	7.91	8.95
269	206	163	132	109	91	78	67	59	51
1.84	2.40	3.05	3.76	4.54	5.38	6.34	7.34	8.51	9.52
143	125	111	100	91	84	77	72	67	63
1.47	1.91	2.42	2.99	3.62	4.34	5.06	5.91	6.76	7.72
403	309	244	198	163	137	117	101	88	77
1.84	2.40	3.04	3.76	4.53	5.40	6.34	7.38	8.46	9.58
215	188	167	151	137	125	116	108	100	94
1.47	1.92	2.43	3.01	3.63	4.31	5.08	5.91	6.73	7.67
351	269	212	172	142	119	102	88	76	67
1.61	2.10	2.66	3.28	3.96	4.71	5.56	6.46	7.34	8.38
187	164	146	131	119	109	101	94	87	82
1.29	1.68	2.13	2.63	3.17	3.78	4.45	5.17	5.88	6.73
526	403	318	258	213	179	153	132	115	101
1.61	2.10	2.66	3.28	3.96	4.73	5.56	6.46	7.41	8.42
281	246	218	197	179	164	151	140	131	123
1.29	1.68	2.13	2.63	3.18	3.79	4.43	5.14	5.91	6.73
444	340	269	218	180	151	129	111	97	85
1.43	1.87	2.37	2.92	3.53	4.20	4.94	5.72	6.58	7.46
237	207	184	166	151	138	128	118	111	104
1.14	1.49	1.89	2.34	2.83	3.36	3.96	4.56	5.27	5.99
666	510	403	327	270	227	193	167	145	128
1.43	1.87	2.37	2.92	3.53	4.21	4.92	5.74	6.56	7.49
355	311	276	249	226	207	191	178	166	156
1.14	1.49	1.89	2.34	2.82	3.36	3.94	4.59	5.26	5.99
548	420	332	269	222	187	159	137	119	105
1.29	1.68	2.13	2.63	3.17	3.79	4.44	5.15	5.89	6.72
293	256	228	205	186	171	158	146	137	128
1.03	1.34	1.71	2.10	2.54	3.03	3.56	4.11	4.74	5.38
823	630	497	403	333	280	239	206	179	158
1.29	1.68	2.13	2.63	3.17	3.78	4.45	5.16	5.90	6.74
439	384	341	307	279	256	236	219	205	192
1.03	1.34	1.70	2.10	2.54	3.03	3.55	4.11	4.73	5.38

\*Weight depends on panel width, cross bar selection, mill tolerance and manufacturing tolerance.

Loads above DO NOT include the dead load of the grating.

**STATIC  
LOAD  
TABLES  
(METRIC)**
**W-22-4 HEAVY DUTY WELDED STEEL GRATING**

(Chart continues on page 46)

No. Bars/Ft. of Width		8.727	Allowable Fiber Stress		137.9 MPa				
No. Bars/Meter of Width		28.63							
U—Uniform Load, kPa			C—Concentrated Load, N/mm of width				D—Deflection, mm		
Bearing Bar Size mm (inches)	Section Modulus per. ft.(304.8mm) width	Moment Inertia	Approx. Wt*(Kg)/ Sq. meter	Span in Millimeters					
					305	457	610	762	914
25 x 6.4 (1 x 1/4)	5 960	75 700	42	U	232	103	58	37	26
				Du	0.53	1.18	2.11	3.27	4.76
				C	35	24	18	14	12
				Dc	0.42	0.96	1.71	2.60	3.84
25 x 9.5 (1 x 3/8)	8 940	113 500	60	U	348	155	87	56	39
				Du	0.53	1.18	2.11	3.30	4.76
				C	53	35	27	21	18
				Dc	0.42	0.93	1.71	2.60	3.84
32 x 6.4 (1 1/4 x 1/4)	9 310	147 800	51	U	362	161	91	58	40
				Du	0.42	0.94	1.69	2.63	3.75
				C	55	37	28	22	18
				Dc	0.34	0.76	1.37	2.09	2.95
32 x 9.5 (1 1/4 x 3/8)	13 970	221 700	73	U	543	242	136	87	61
				Du	0.42	0.94	1.69	2.63	3.81
				C	83	55	41	33	28
				Dc	0.34	0.75	1.33	2.09	3.06
38 x 6.4 (1 1/2 x 1/4)	13 410	255 400	60	U	522	232	130	84	58
				Du	0.35	0.79	1.40	2.20	3.14
				C	80	53	40	32	27
				Dc	0.28	0.63	1.13	1.76	2.56
38 x 9.5 (1 1/2 x 3/8)	20 110	383 100	87	U	782	349	196	125	87
				Du	0.35	0.79	1.41	2.18	3.14
				C	119	80	60	48	40
				Dc	0.28	0.63	1.13	1.76	2.53
44 x 6.4 (1 3/4 x 1/4)	18 250	405 600	69	U	710	316	178	114	79
				Du	0.30	0.67	1.21	1.88	2.70
				C	108	72	54	43	36
				Dc	0.24	0.54	0.96	1.49	2.15
44 x 9.5 (1 3/4 x 3/8)	27 370	608 400	100	U	1065	474	266	171	119
				Du	0.30	0.67	1.20	1.88	2.71
				C	162	108	81	65	54
				Dc	0.24	0.54	0.96	1.50	2.15
51 x 6.4 (2 x 1/4)	23 840	605 400	78	U	927	413	232	149	103
				Du	0.26	0.59	1.05	1.65	2.36
				C	141	94	71	57	47
				Dc	0.21	0.47	0.85	1.32	1.88
51 x 9.5 (2 x 3/8)	35 750	908 100	114	U	1391	620	348	223	155
				Du	0.26	0.59	1.05	1.64	2.36
				C	212	142	106	85	71
				Dc	0.21	0.47	0.84	1.31	1.90
57 x 6.4 (2 1/4 x 1/4)	30 170	862 000	87	U	1174	523	293	188	131
				Du	0.23	0.53	0.93	1.46	2.10
				C	179	119	89	72	60
				Dc	0.19	0.42	0.74	1.17	1.69
57 x 9.5 (2 1/4 x 3/8)	45 250	1 293 000	128	U	1761	784	440	282	196
				Du	0.23	0.52	0.93	1.46	2.10
				C	268	179	134	107	90
				Dc	0.19	0.42	0.75	1.16	1.69

NOTE: When serrated grating is specified, the depth of grating required for specific load will be the next depth greater than that shown in these tables.

Loads above DO NOT include the dead load of the grating.

**STATIC  
LOAD  
TABLES  
(METRIC)**

(Chart begins on page 45)

U—Uniform Load, kPa		C—Concentrated Load, N/mm of Width						D—Deflection,mm	
Span in Millimeters									
1067	1219	1372	1524	1676	1829	1981	2134	2286	2438
19	15	11	9	8	6	5	5	4	4
6.46	8.69	10.22	12.73	16.55	17.61	20.19	27.19	28.64	37.06
10	9	8	7	6	6	5	5	5	4
5.10	6.84	8.67	10.40	11.85	15.40	16.31	20.39	25.06	24.32
28	22	17	14	12	10	8	7	6	5
6.34	8.49	10.53	13.20	16.55	19.56	21.54	25.38	28.64	30.88
15	13	12	11	10	9	8	8	7	7
5.10	6.59	8.67	10.89	13.17	15.40	17.40	21.75	23.39	28.37
30	23	18	15	12	10	9	7	6	6
5.22	6.82	8.56	10.86	12.71	15.02	18.61	19.49	22.00	28.46
16	14	12	11	10	9	9	8	7	7
4.18	5.45	6.66	8.36	10.11	11.83	15.03	16.70	17.96	21.79
44	34	27	22	18	15	13	11	10	9
5.10	6.72	8.56	10.62	12.71	15.02	17.92	20.42	24.44	28.46
24	21	18	17	15	14	13	12	11	10
4.18	5.45	6.66	8.62	10.11	12.27	14.47	16.70	18.82	20.75
43	33	26	21	17	15	12	11	9	8
4.33	5.66	7.16	8.80	10.42	13.04	14.36	17.72	19.10	21.96
23	20	18	16	14	13	12	11	11	10
3.47	4.50	5.78	7.04	8.19	9.89	11.60	13.29	16.34	18.01
64	49	39	31	26	22	19	16	14	12
4.30	5.60	7.16	8.66	10.63	12.75	15.16	17.19	19.80	21.96
34	30	27	24	22	20	18	17	16	15
3.42	4.50	5.78	7.04	8.58	10.14	11.60	13.69	15.84	18.01
58	44	35	28	24	20	17	15	13	11
3.68	4.75	6.07	7.39	9.27	10.95	12.81	15.22	17.37	19.01
31	27	24	22	20	18	17	15	14	14
2.95	3.83	4.85	6.10	7.37	8.62	10.35	11.41	13.09	15.88
87	67	53	43	35	30	25	22	19	17
3.68	4.83	6.13	7.57	9.01	10.95	12.56	14.88	16.92	19.59
46	41	36	33	30	27	25	23	22	20
2.92	3.88	4.85	6.10	7.37	8.62	10.14	11.67	13.72	15.13
76	58	46	37	31	26	22	19	17	15
3.23	4.20	5.34	6.54	8.02	9.54	11.11	12.92	15.22	17.37
40	35	31	28	26	24	22	20	19	18
2.55	3.32	4.20	5.20	6.42	7.70	8.97	10.19	11.90	13.68
114	87	69	56	46	39	33	28	25	22
3.23	4.20	5.34	6.60	7.93	9.54	11.11	12.69	14.92	16.98
61	53	47	42	39	35	33	30	28	27
2.59	3.36	4.24	5.20	6.42	7.49	8.97	10.19	11.69	13.68
96	73	58	47	39	33	28	24	21	18
2.86	3.71	4.73	5.84	7.08	8.50	9.93	11.46	13.20	14.64
51	45	40	36	33	30	28	26	24	22
2.28	3.00	3.81	4.69	5.72	6.76	8.02	9.31	10.56	11.74
144	110	87	71	58	49	42	36	31	28
2.86	3.73	4.73	5.88	7.02	8.42	9.93	11.46	12.99	15.18
77	67	60	54	49	45	41	38	36	34
2.30	2.98	3.81	4.69	5.66	6.76	7.83	9.07	10.56	12.10

\*Weight depends on panel width, cross bar selection, mill tolerance and manufacturing tolerance.

Loads above DO NOT include the dead load of the grating.



**STATIC  
LOAD  
TABLES  
(METRIC)**
**W-22-4 HEAVY DUTY WELDED STEEL GRATING (con't.)**

(Chart continues on page 48)

No. Bars/Ft. of Width		8.727	Allowable Fiber Stress		137.9 MPa				
No. Bars/Meter of Width		28.63							
U—Uniform Load, kPa			C—Concentrated Load, N/mm of width				D—Deflection, mm		
Bearing Bar Size mm (inches)	Section Modulus per. ft.(304.8mm) width	Moment Inertia	Approx. Wt*(Kg/ Sq. meter	Span in Millimeters					
					305	457	610	762	914
64 x 6.4 (2½ x ¼)	37 240	1 182 000	96	U	1449	645	362	232	161
				Du	0.21	0.47	0.84	1.31	1.89
				C	221	147	110	88	74
				Dc	0.17	0.38	0.67	1.05	1.52
64 x 9.5 (2½ x ⅜)	55 900	1 774 000	141	U	2174	968	543	348	242
				Du	0.21	0.47	0.84	1.31	1.89
				C	331	221	166	133	111
				Dc	0.17	0.38	0.67	1.05	1.52
76 x 6.4 (3 x ¼)	53 600	2 043 000	114	U	2087	929	522	334	232
				Du	0.18	0.39	0.70	1.09	1.57
				C	318	212	159	127	106
				Dc	0.14	0.31	0.56	0.87	1.26
76 x 9.5 (3 x ⅜)	80 400	3 065 000	168	U	3130	1394	782	501	349
				Du	0.18	0.39	0.70	1.09	1.58
				C	477	319	239	191	159
				Dc	0.14	0.32	0.56	0.88	1.26
89 x 6.4 (3½ x ¼)	73 000	3 245 000	132	U	2840	1265	710	455	316
				Du	0.15	0.34	0.60	0.94	1.35
				C	433	289	217	173	145
				Dc	0.12	0.27	0.48	0.75	1.08
89 x 9.5 (3½ x ⅜)	109 500	4 867 000	196	U	4260	1898	1065	683	474
				Du	0.15	0.34	0.60	0.94	1.35
				C	650	434	325	260	217
				Dc	0.12	0.27	0.48	0.75	1.08
102 x 6.4 (4 x ¼)	95 300	4 843 000	150	U	3709	1652	927	594	413
				Du	0.13	0.30	0.53	0.82	1.18
				C	566	378	283	226	189
				Dc	0.11	0.24	0.42	0.66	0.95
102 x 9.5 (4 x ⅜)	143 000	7 265 000	223	U	5564	2478	1391	891	620
				Du	0.13	0.30	0.53	0.82	1.18
				C	849	566	424	340	283
				Dc	0.11	0.24	0.42	0.66	0.94
114 x 6.4 (4½ x ¼)	120 700	6 896 000	168	U	4695	2091	1174	752	523
				Du	0.12	0.26	0.47	0.73	1.05
				C	716	478	358	287	239
				Dc	0.09	0.21	0.37	0.58	0.84
114 x 9.5 (4½ x ⅜)	181 000	10 344 000	250	U	7042	3137	1761	1128	784
				Du	0.12	0.26	0.47	0.73	1.05
				C	1074	717	537	430	358
				Dc	0.09	0.21	0.37	0.58	0.84
127 x 6.4 (5 x ¼)	149 000	9 460 000	186	U	5796	2582	1449	929	645
				Du	0.11	0.24	0.42	0.66	0.94
				C	884	590	442	354	295
				Dc	0.08	0.19	0.34	0.53	0.76
127 x 9.5 (5 x ⅜)	233 500	14 189 000	277	U	8694	3873	2174	1393	968
				Du	0.11	0.24	0.42	0.66	0.94
				C	1326	885	663	531	442
				Dc	0.08	0.19	0.34	0.53	0.76

NOTE: When serrated grating is specified, the depth of grating required for specific load will be the next depth greater than that shown in these tables.

Loads above DO NOT include the dead load of the grating.



**STATIC  
LOAD  
TABLES  
(METRIC)**

(Chart begins on page 47)

U—Uniform Load, kPa		C—Concentrated Load, N/mm of Width						D—Deflection,mm	
Span in Millimeters									
1067	1219	1372	1524	1676	1829	1981	2134	2286	2438
118	91	72	58	48	40	34	30	26	23
2.57	3.37	4.28	5.25	6.36	7.51	8.79	10.44	11.92	13.64
63	55	49	44	40	37	34	32	29	28
2.05	2.68	3.40	4.18	5.06	6.08	7.10	8.35	9.30	10.89
178	136	107	87	72	60	52	44	39	34
2.58	3.36	4.24	5.25	6.36	7.51	8.96	10.21	11.92	13.44
95	83	74	66	60	55	51	47	44	41
2.07	2.69	3.42	4.18	5.06	6.02	7.10	8.18	9.41	10.64
170	131	103	84	69	58	49	43	37	33
2.14	2.81	3.54	4.40	5.29	6.30	7.33	8.66	9.81	11.32
91	80	71	64	58	53	49	45	42	40
1.72	2.25	2.85	3.52	4.24	5.04	5.92	6.80	7.80	9.01
256	196	155	125	104	87	74	64	56	49
2.15	2.80	3.56	4.37	5.31	6.30	7.38	8.59	9.90	11.21
136	119	106	96	87	80	73	68	64	60
1.71	2.23	2.84	3.52	4.24	5.07	5.88	6.85	7.92	9.01
232	178	140	114	94	79	67	58	51	44
1.84	2.40	3.03	3.76	4.54	5.41	6.31	7.36	8.52	9.51
124	108	96	87	79	72	67	62	58	54
1.47	1.91	2.43	3.01	3.64	4.31	5.10	5.90	6.78	7.66
348	267	211	171	141	118	101	87	76	67
1.84	2.40	3.05	3.76	4.54	5.38	6.34	7.36	8.46	9.65
186	163	144	130	118	108	100	93	87	81
1.47	1.93	2.43	3.00	3.62	4.31	5.07	5.90	6.78	7.66
303	232	183	149	123	103	88	76	66	58
1.61	2.10	2.66	3.29	3.98	4.72	5.55	6.46	7.38	8.40
162	142	126	113	103	94	87	81	75	71
1.29	1.69	2.13	2.62	3.18	3.77	4.43	5.16	5.87	6.74
455	348	275	223	184	155	132	114	99	87
1.61	2.10	2.66	3.29	3.97	4.74	5.55	6.46	7.38	8.40
243	212	189	170	154	142	131	121	113	106
1.29	1.68	2.13	2.63	3.17	3.80	4.45	5.14	5.90	6.71
384	294	232	188	155	131	111	96	84	73
1.43	1.87	2.37	2.92	3.52	4.22	4.92	5.73	6.60	7.42
205	179	159	143	130	119	110	102	96	90
1.15	1.49	1.89	2.33	2.82	3.35	3.94	4.56	5.28	6.00
575	441	348	282	233	196	167	144	125	110
1.43	1.87	2.37	2.92	3.53	4.21	4.93	5.73	6.55	7.46
307	269	239	215	195	179	165	153	143	134
1.14	1.50	1.89	2.34	2.82	3.36	3.94	4.56	5.24	5.96
474	363	286	232	192	161	137	118	103	91
1.29	1.68	2.13	2.63	3.18	3.78	4.43	5.13	5.90	6.74
253	221	196	177	161	147	136	126	118	111
1.03	1.34	1.70	2.10	2.54	3.02	3.55	4.11	4.73	5.40
710	544	430	348	288	242	206	178	155	136
1.29	1.68	2.13	2.63	3.18	3.79	4.44	5.16	5.92	6.72
379	332	295	265	241	221	204	189	177	166
1.03	1.35	1.70	2.10	2.54	3.03	3.55	4.11	4.73	5.38

\*Weight depends on panel width, cross bar selection, mill tolerance and manufacturing tolerance.

Loads above DO NOT include the dead load of the grating.

**STATIC  
LOAD  
TABLES  
(METRIC)**

**W-30-4 HEAVY DUTY WELDED STEEL GRATING**

(Chart continues on page 50)

No. Bars/Ft. of Width		6.400	Allowable Fiber Stress		137.9 MPa				
No. Bars/Meter of Width		20.99							
U—Uniform Load, kPa			C—Concentrated Load, N/mm of width				D—Deflection,mm		
Bearing Bar Size mm (inches)	Section Modulus per. ft.(304.8mm) width	Moment Inertia	Approx. Wt*(Kg)/ Sq. meter	Span in Millimeters					
					305	457	610	762	914
25 x 6.4 (1 x 1/4)	4 370	55 500	32	U	170	76	43	27	19
				Du	0.53	1.19	2.13	3.25	4.74
				C	26	17	13	10	9
				Dc	0.42	0.93	1.69	2.53	3.93
25 x 9.5 (1 x 3/8)	6 550	83 200	45	U	255	114	64	41	28
				Du	0.53	1.19	2.11	3.30	4.66
				C	39	26	19	16	13
				Dc	0.42	0.95	1.64	2.70	3.79
32 x 6.4 (1 1/4 x 1/4)	6 830	108 400	39	U	266	118	66	43	30
				Du	0.42	0.94	1.67	2.65	3.83
				C	41	27	20	16	14
				Dc	0.34	0.75	1.33	2.07	3.13
32 x 9.5 (1 1/4 x 3/8)	10 240	162 600	55	U	398	177	100	64	44
				Du	0.42	0.94	1.69	2.63	3.75
				C	61	41	30	24	20
				Dc	0.34	0.76	1.33	2.07	2.98
38 x 6.4 (1 1/2 x 1/4)	9 830	187 300	45	U	383	170	96	61	43
				Du	0.35	0.79	1.41	2.18	3.18
				C	58	39	29	23	19
				Dc	0.28	0.63	1.12	1.73	2.46
38 x 9.5 (1 1/2 x 3/8)	14 750	281 000	65	U	574	256	143	92	64
				Du	0.35	0.79	1.40	2.19	3.15
				C	88	58	44	35	29
				Dc	0.28	0.63	1.13	1.75	2.50
44 x 6.4 (1 3/4 x 1/4)	13 380	297 400	52	U	521	232	130	83	58
				Du	0.30	0.68	1.20	1.87	2.70
				C	79	53	40	32	26
				Dc	0.24	0.54	0.97	1.51	2.12
44 x 9.5 (1 3/4 x 3/8)	20 070	446 100	75	U	781	348	195	125	87
				Du	0.30	0.68	1.20	1.87	2.70
				C	119	79	60	48	40
				Dc	0.24	0.54	0.97	1.51	2.17
51 x 6.4 (2 x 1/4)	17 480	444 000	59	U	680	303	170	109	76
				Du	0.26	0.59	1.05	1.64	2.37
				C	104	69	52	42	35
				Dc	0.21	0.47	0.84	1.33	1.91
51 x 9.5 (2 x 3/8)	26 220	666 000	85	U	1020	454	255	163	114
				Du	0.26	0.59	1.05	1.64	2.37
				C	156	104	78	62	52
				Dc	0.21	0.47	0.84	1.31	1.89
57 x 6.4 (2 1/4 x 1/4)	22 120	632 200	65	U	861	383	215	138	96
				Du	0.23	0.52	0.93	1.46	2.10
				C	131	88	66	53	44
				Dc	0.19	0.42	0.75	1.18	1.69
57 x 9.5 (2 1/4 x 3/8)	33 180	948 200	95	U	1291	575	323	207	144
				Du	0.23	0.52	0.94	1.46	2.10
				C	197	131	98	79	66
				Dc	0.19	0.42	0.74	1.17	1.69

NOTE: When serrated grating is specified, the depth of grating required for specific load will be the next depth greater than that shown in these tables.

Loads above DO NOT include the dead load of the grating.

**STATIC  
LOAD  
TABLES  
(METRIC)**

**(Chart begins on page 49)**

U—Uniform Load, kPa			C—Concentrated Load, N/mm of Width				D—Deflection,mm		
Span in Millimeters									
1067	1219	1372	1524	1676	1829	1981	2134	2286	2438
14	11	8	7	6	5	4	3	3	3
6.49	8.68	10.14	13.50	16.93	20.01	22.03	22.25	29.29	37.90
7	6	6	5	5	4	4	4	3	3
4.86	6.22	8.87	10.13	13.47	14.00	17.79	22.24	20.50	24.87
21	16	13	10	8	7	6	5	5	4
6.49	8.42	10.98	12.86	15.05	18.67	22.03	24.72	32.55	33.69
11	10	9	8	7	6	6	6	5	5
5.10	6.91	8.87	10.80	12.57	14.00	17.79	22.24	22.78	27.63
22	17	13	11	9	7	6	5	5	4
5.22	6.87	8.43	10.86	13.00	14.34	16.92	18.98	25.00	25.87
12	10	9	8	7	7	6	6	5	5
4.27	5.31	6.81	8.29	9.65	12.55	13.66	17.08	17.50	21.22
33	25	20	16	13	11	9	8	7	6
5.22	6.74	8.65	10.53	12.52	15.02	16.92	20.25	23.33	25.87
17	15	14	12	11	10	9	9	8	8
4.03	5.31	7.06	8.29	10.11	11.95	13.66	17.08	18.66	22.64
31	24	19	15	13	11	9	8	7	6
4.26	5.61	7.13	8.57	10.87	13.04	14.68	17.58	20.25	22.46
17	15	13	12	11	10	9	8	8	7
3.50	4.61	5.69	7.20	8.78	10.37	11.86	13.18	16.20	17.19
47	36	28	23	19	16	14	12	10	9
4.30	5.61	7.01	8.76	10.59	12.65	15.23	17.58	19.29	22.46
25	22	19	18	16	15	13	13	12	11
3.43	4.50	5.55	7.20	8.51	10.37	11.42	14.28	16.20	18.01
43	33	26	21	17	14	12	11	9	8
3.72	4.86	6.15	7.56	8.95	10.45	12.33	15.22	16.40	18.86
23	20	18	16	14	13	12	11	11	10
2.98	3.87	4.96	6.05	7.04	8.49	9.96	11.41	14.03	15.47
64	49	39	31	26	22	19	16	14	12
3.69	4.81	6.15	7.44	9.12	10.95	13.01	14.76	17.01	18.86
34	30	26	24	22	20	18	17	16	15
2.94	3.87	4.78	6.05	7.37	8.71	9.96	11.76	13.60	15.47
56	43	34	27	23	19	16	14	12	11
3.24	4.24	5.38	6.51	8.11	9.50	11.01	12.98	14.65	17.37
30	26	23	21	19	17	16	15	14	13
2.61	3.37	4.25	5.32	6.40	7.44	8.90	10.42	11.96	13.47
83	64	50	41	34	28	24	21	18	16
3.21	4.21	5.28	6.59	7.99	9.34	11.01	12.98	14.65	16.84
44	39	35	31	28	26	24	22	21	19
2.55	3.37	4.31	5.23	6.28	7.58	8.90	10.19	11.96	13.13
70	54	43	34	29	24	20	18	15	13
2.85	3.74	4.78	5.76	7.18	8.43	9.67	11.72	12.86	14.42
38	33	29	26	24	22	20	19	18	16
2.32	3.00	3.76	4.62	5.67	6.76	7.81	9.27	10.80	11.65
105	81	64	52	43	36	31	26	23	20
2.85	3.74	4.75	5.87	7.10	8.43	9.99	11.28	13.14	14.79
56	49	44	39	36	33	30	28	26	25
2.28	2.97	3.80	4.62	5.67	6.76	7.81	9.11	10.40	12.13

\*Weight depends on panel width, cross bar selection, mill tolerance and manufacturing tolerance.

Loads above DO NOT include the dead load of the grating.

**STATIC  
LOAD  
TABLES  
(METRIC)**
**W-30-4 HEAVY DUTY WELDED STEEL GRATING (con't.) (Chart continues on page 52)**

No. Bars/Ft. of Width		6.400		Allowable Fiber Stress		137.9 MPa			
No. Bars/Meter of Width		20.99							
U—Uniform Load, kPa				C—Concentrated Load, N/mm of width				D—Deflection, mm	
Bearing Bar Size mm (inches)	Section Modulus per. ft.(304.8mm) width	Moment Inertia	Approx. Wt*(Kg)/ Sq. meter	Span in Millimeters					
					305	457	610	762	914
64 x 6.4 (2 1/2 x 1/4)	27 300	867 100	72	U	1063	473	266	170	118
				Du	0.21	0.47	0.84	1.31	1.88
				C	162	108	81	65	54
				Dc	0.17	0.38	0.67	1.05	1.51
64 x 9.5 (2 1/2 x 3/8)	41 000	1 301 000	105	U	1594	710	398	255	177
				Du	0.21	0.47	0.84	1.31	1.88
				C	243	162	122	97	81
				Dc	0.17	0.38	0.68	1.05	1.51
76 x 6.4 (3 x 1/4)	39 300	1 498 000	85	U	1530	682	383	245	170
				Du	0.18	0.39	0.70	1.09	1.57
				C	233	156	117	93	78
				Dc	0.14	0.32	0.56	0.87	1.26
76 x 9.5 (3 x 3/8)	59 000	2 248 000	125	U	2295	1022	574	368	256
				Du	0.18	0.39	0.70	1.10	1.58
				C	350	234	175	140	117
				Dc	0.14	0.32	0.56	0.87	1.26
89 x 6.4 (3 1/2 x 1/4)	53 500	2 379 000	98	U	2083	928	521	334	232
				Du	0.15	0.34	0.60	0.94	1.35
				C	318	212	159	127	106
				Dc	0.12	0.27	0.48	0.75	1.08
89 x 9.5 (3 1/2 x 3/8)	80 300	3 569 000	145	U	3124	1392	781	501	348
				Du	0.15	0.34	0.60	0.94	1.35
				C	476	318	238	191	159
				Dc	0.12	0.27	0.48	0.75	1.08
102 x 6.4 (4 x 1/4)	69 900	3 552 000	112	U	2720	1212	680	436	303
				Du	0.13	0.30	0.53	0.82	1.18
				C	415	277	207	166	138
				Dc	0.11	0.24	0.42	0.66	0.94
102 x 9.5 (4 x 3/8)	104 900	5 328 000	165	U	4081	1818	1020	654	454
				Du	0.13	0.30	0.53	0.82	1.18
				C	622	415	311	249	208
				Dc	0.11	0.24	0.42	0.66	0.95
114 x 6.4 (4 1/2 x 1/4)	88 500	5 057 000	125	U	3443	1534	861	552	383
				Du	0.12	0.26	0.47	0.73	1.05
				C	525	350	263	210	175
				Dc	0.09	0.21	0.37	0.58	0.84
114 x 9.5 (4 1/2 x 3/8)	132 700	7 586 000	185	U	5164	2300	1291	827	575
				Du	0.12	0.26	0.47	0.73	1.05
				C	788	526	394	315	263
				Dc	0.09	0.21	0.37	0.58	0.84
127 x 6.4 (5 x 1/4)	109 200	6 937 000	138	U	4251	1893	1063	681	473
				Du	0.11	0.24	0.42	0.66	0.94
				C	648	433	324	259	216
				Dc	0.08	0.19	0.34	0.52	0.75
127 x 9.5 (5 x 3/8)	163 900	10 406 000	205	U	6376	2840	1594	1021	710
				Du	0.11	0.24	0.42	0.66	0.94
				C	972	649	486	389	324
				Dc	0.08	0.19	0.34	0.53	0.75

NOTE: When serrated grating is specified, the depth of grating required for specific load will be the next depth greater than that shown in these tables.

Loads above DO NOT include the dead load of the grating.



**STATIC  
LOAD  
TABLES  
(METRIC)**

(Chart begins on page 51)

U—Uniform Load, kPa		C—Concentrated Load, N/mm of Width						D—Deflection,mm	
Span in Millimeters									
1067	1219	1372	1524	1676	1829	1981	2134	2286	2438
87	67	53	43	35	30	25	22	19	17
2.58	3.39	4.30	5.31	6.32	7.68	8.81	10.44	11.87	13.74
46	41	36	32	29	27	25	23	22	20
2.05	2.72	3.40	4.15	5.00	6.05	7.12	8.18	9.62	10.61
130	100	79	64	53	44	38	33	28	25
2.57	3.37	4.27	5.27	6.38	7.51	8.93	10.44	11.67	13.47
69	61	54	49	44	41	37	35	32	30
2.05	2.70	3.40	4.23	5.06	6.12	7.02	8.30	9.33	10.61
125	96	76	61	51	43	36	31	27	24
2.15	2.81	3.57	4.36	5.33	6.37	7.34	8.51	9.76	11.23
67	58	52	47	42	39	36	33	31	29
1.72	2.23	2.85	3.53	4.19	5.06	5.93	6.80	7.85	8.90
188	144	113	92	76	64	54	47	41	36
2.15	2.81	3.54	4.38	5.29	6.32	7.34	8.61	9.89	11.23
100	88	78	70	64	58	54	50	47	44
1.72	2.25	2.85	3.50	4.26	5.01	5.93	6.86	7.93	9.01
170	130	103	83	69	58	49	43	37	33
1.84	2.39	3.04	3.73	4.54	5.41	6.29	7.44	8.43	9.72
91	79	71	64	58	53	49	45	42	40
1.48	1.91	2.45	3.02	3.64	4.33	5.08	5.84	6.69	7.73
255	196	154	125	103	87	74	64	56	49
1.84	2.41	3.03	3.75	4.52	5.41	6.34	7.38	8.50	9.62
136	119	106	95	87	79	73	68	64	60
1.47	1.92	2.44	2.99	3.64	4.30	5.05	5.88	6.80	7.73
222	170	134	109	90	76	64	56	48	43
1.61	2.10	2.65	3.29	3.97	4.75	5.51	6.49	7.32	8.49
119	104	92	83	75	69	64	59	55	52
1.29	1.68	2.12	2.63	3.16	3.77	4.45	5.13	5.87	6.74
333	255	202	163	135	113	97	83	73	64
1.61	2.10	2.67	3.27	3.97	4.71	5.56	6.41	7.43	8.42
178	156	138	125	113	104	96	89	83	78
1.29	1.68	2.12	2.64	3.17	3.79	4.45	5.15	5.91	6.74
281	216	170	138	114	96	82	70	61	54
1.43	1.87	2.36	2.92	3.53	4.22	4.96	5.70	6.54	7.49
150	131	117	105	96	88	81	75	70	66
1.14	1.49	1.90	2.33	2.84	3.38	3.95	4.58	5.25	6.00
422	323	255	207	171	144	122	105	92	81
1.43	1.87	2.36	2.92	3.53	4.22	4.91	5.70	6.57	7.49
225	197	175	158	143	131	121	113	105	99
1.14	1.49	1.89	2.34	2.82	3.35	3.94	4.60	5.25	6.00
347	266	210	170	141	118	101	87	76	67
1.29	1.68	2.13	2.62	3.18	3.78	4.45	5.16	5.94	6.77
185	162	144	130	118	108	100	93	86	81
1.03	1.34	1.70	2.11	2.54	3.02	3.56	4.14	4.70	5.37
521	399	315	255	211	177	151	130	113	100
1.29	1.68	2.13	2.62	3.17	3.78	4.43	5.14	5.88	6.74
278	243	216	195	177	162	150	139	130	122
1.03	1.34	1.70	2.11	2.54	3.02	3.56	4.12	4.74	5.39

\*Weight depends on panel width, cross bar selection, mill tolerance and manufacturing tolerance.

Loads above DO NOT include the dead load of the grating.



**STATIC  
LOAD  
TABLES  
(METRIC)**

**W-38-4 HEAVY DUTY WELDED STEEL GRATING****(Chart continues on page 54)**

No. Bars/Ft. of Width		5.053	Allowable Fiber Stress		137.9 MPa				
No. Bars/Meter of Width		16.57							
U—Uniform Load, kPa			C—Concentrated Load, N/mm of width					D—Deflection,mm	
Bearing Bar Size mm (inches)	Section Modulus per. ft.(304.8mm) width	Moment Inertia	Approx. Wt*(Kg)/ Sq. meter	Span in Millimeters					
					305	457	610	762	914
25 x 6.4 (1 x 1/4)	3 450	43 800	26	U	134	60	34	22	15
				Du	0.53	1.19	2.13	3.36	4.74
				C	20	14	10	8	7
				Dc	0.41	0.97	1.64	2.56	3.87
25 x 9.5 (1 x 3/8)	5 180	65 700	37	U	201	90	50	32	22
				Du	0.53	1.19	2.09	3.26	4.64
				C	31	20	15	12	10
				Dc	0.42	0.92	1.64	2.56	3.69
32 x 6.4 (1 1/4 x 1/4)	5 390	85 600	32	U	210	93	52	34	23
				Du	0.42	0.94	1.67	2.66	3.72
				C	32	21	16	13	11
				Dc	0.34	0.74	1.35	2.13	3.12
32 x 9.5 (1 1/4 x 3/8)	8 090	128 400	45	U	315	140	79	50	35
				Du	0.42	0.94	1.69	2.61	3.78
				C	48	32	24	19	16
				Dc	0.34	0.76	1.35	2.08	3.02
38 x 6.4 1 1/2 x 1/4)	7 760	148 900	37	U	302	135	76	48	34
				Du	0.35	0.79	1.41	2.17	3.18
				C	46	31	23	18	15
				Dc	0.28	0.64	1.12	1.71	2.46
38 x 9.5 1 1/2 x 3/8)	11 640	221 800	53	U	453	202	113	73	50
				Du	0.35	0.79	1.40	2.20	3.12
				C	69	46	35	28	23
				Dc	0.28	0.63	1.14	1.77	2.51
44 x 6.4 1 3/4 x 1/4)	10 570	234 800	42	U	411	183	103	66	46
				Du	0.30	0.67	1.21	1.88	2.71
				C	63	42	31	25	21
				Dc	0.24	0.54	0.95	1.50	2.17
44 x 9.5 (1 3/4 x 3/8)	15 850	352 200	60	U	617	275	154	99	69
				Du	0.30	0.68	1.20	1.88	2.71
				C	94	63	47	38	31
				Dc	0.24	0.54	0.96	1.52	2.13
51 x 6.4 (2 x 1/4)	13 800	350 500	47	U	537	239	134	86	60
				Du	0.26	0.59	1.05	1.64	2.37
				C	82	55	41	33	27
				Dc	0.21	0.48	0.84	1.32	1.87
51 x 9.5 (2 x 3/8)	20 700	525 800	68	U	805	359	201	129	90
				Du	0.26	0.59	1.05	1.64	2.37
				C	123	82	61	49	41
				Dc	0.21	0.47	0.84	1.31	1.89
57 x 6.4 (2 1/4 x 1/4)	17 470	499 100	53	U	680	303	170	109	76
				Du	0.23	0.53	0.94	1.46	2.11
				C	104	69	52	41	35
				Dc	0.19	0.42	0.75	1.15	1.70
57 x 9.5 (2 1/4 x 3/8)	26 200	748 700	76	U	1019	454	255	163	114
				Du	0.23	0.52	0.94	1.46	2.11
				C	155	104	78	62	52
				Dc	0.19	0.42	0.75	1.16	1.68

NOTE: When serrated grating is specified, the depth of grating required for specific load will be the next depth greater than that shown in these tables.

Loads above DO NOT include the dead load of the grating.

**STATIC  
LOAD  
TABLES  
(METRIC)**

(Chart begins on page 53)

U—Uniform Load, kPa			C—Concentrated Load, N/mm of Width				D—Deflection,mm		
Span in Millimeters									
1067	1219	1372	1524	1676	1829	1981	2134	2286	2438
11	8	7	5	4	4	3	3	2	2
6.46	8.00	11.23	12.21	14.29	20.27	20.92	28.18	24.74	32.00
6	5	5	4	4	3	3	3	3	3
5.28	6.56	9.36	10.26	13.65	13.30	16.90	21.13	25.97	31.50
16	13	10	8	7	6	5	4	4	3
6.26	8.67	10.70	13.03	16.68	20.27	23.25	25.05	32.98	32.00
9	8	7	6	6	5	5	4	4	4
5.28	7.00	8.73	10.26	13.65	14.78	18.78	18.78	23.08	28.00
17	13	10	8	7	6	5	4	4	3
5.11	6.66	8.22	10.01	12.81	15.57	17.85	19.23	25.33	24.58
9	8	7	6	6	5	5	5	4	4
4.06	5.38	6.71	7.88	10.48	11.35	14.42	18.03	17.73	21.50
26	20	16	13	10	9	7	6	6	5
5.21	6.83	8.76	10.84	12.20	15.57	16.66	19.23	25.33	27.31
14	12	11	10	9	8	7	7	6	6
4.21	5.38	7.03	8.75	10.48	12.11	13.46	16.83	17.73	21.50
25	19	15	12	10	8	7	6	5	5
4.35	5.63	7.13	8.69	10.59	12.01	14.47	16.70	18.32	23.70
13	12	10	9	8	8	7	7	6	6
3.39	4.67	5.54	6.84	8.09	10.51	11.68	14.61	15.39	18.67
37	28	22	18	15	13	11	9	8	7
4.29	5.53	6.97	8.69	10.59	13.01	15.15	16.70	19.54	22.12
20	17	15	14	13	12	11	10	9	9
3.48	4.41	5.54	7.09	8.76	10.51	12.24	13.91	15.39	18.67
34	26	20	16	14	11	10	8	7	6
3.72	4.85	5.99	7.29	9.33	10.40	13.01	14.02	16.15	17.91
18	16	14	13	11	10	10	9	8	8
2.96	3.92	4.89	6.22	7.00	8.27	10.51	11.83	12.92	15.67
50	39	30	25	20	17	15	13	11	10
3.65	4.85	5.99	7.60	8.89	10.72	13.01	15.19	16.92	19.90
27	24	21	19	17	16	14	13	13	12
2.96	3.92	4.89	6.06	7.21	8.82	9.81	11.39	14.00	15.67
44	34	27	22	18	15	13	11	10	8
3.23	4.25	5.42	6.72	8.04	9.50	11.33	12.91	15.46	16.00
23	20	18	16	15	14	13	12	11	10
2.53	3.28	4.21	5.13	6.40	7.76	9.15	10.56	11.90	13.13
66	50	40	32	27	22	19	16	14	13
3.23	4.17	5.35	6.51	8.04	9.29	11.04	12.52	14.43	17.33
35	31	27	25	22	20	19	18	16	15
2.57	3.39	4.21	5.34	6.25	7.39	8.92	10.56	11.54	13.13
56	43	34	27	23	19	16	14	12	11
2.89	3.77	4.79	5.79	7.22	8.45	9.80	11.54	13.03	15.45
30	26	23	21	19	17	16	15	14	13
2.32	3.00	3.78	4.73	5.69	6.62	7.91	9.27	10.64	11.98
83	64	50	41	34	28	24	21	18	16
2.85	3.75	4.70	5.86	7.11	8.31	9.80	11.54	13.03	14.98
44	39	35	31	28	26	24	22	21	19
2.27	3.00	3.83	4.65	5.59	6.75	7.91	9.07	10.64	11.68

\*Weight depends on panel width, cross bar selection, mill tolerance and manufacturing tolerance.

Loads above DO NOT include the dead load of the grating.

**STATIC  
LOAD  
TABLES  
(METRIC)**

**W-38-4 HEAVY DUTY WELDED STEEL GRATING (con't.)** (Chart continues on page 56)

No. Bars/Ft. of Width		5.053		Allowable Fiber Stress		137.9 MPa			
No. Bars/Meter of Width		16.57							
U—Uniform Load, kPa				C—Concentrated Load, N/mm of width			D—Deflection,mm		
Bearing Bar Size mm (inches)	Section Modulus per. ft.(304.8mm) width	Moment Inertia	Approx. Wt*(Kg)/ Sq. meter	Span in Millimeters					
				305	457	610	762	914	
64 x 6.4 (2½ x ¼)	21 560	685 000	58	U	839	374	210	134	93
				Du	0.21	0.47	0.84	1.31	1.88
				C	128	85	64	51	43
				Dc	0.17	0.38	0.67	1.05	1.52
64 x 9.5 (2½ x ⅜)	32 350	1 027 000	84	U	1258	561	315	202	140
				Du	0.21	0.47	0.84	1.32	1.89
				C	192	128	96	77	64
				Dc	0.17	0.38	0.67	1.05	1.51
76 x 6.4 (3 x ¼)	31 050	1 183 000	68	U	1208	538	302	194	135
				Du	0.18	0.39	0.70	1.10	1.58
				C	184	123	92	74	61
				Dc	0.14	0.32	0.56	0.88	1.25
76 x 9.5 (3 x ⅜)	46 600	1 775 000	100	U	1812	807	453	290	202
				Du	0.18	0.39	0.70	1.09	1.58
				C	276	184	138	111	92
				Dc	0.14	0.31	0.56	0.88	1.26
89 x 6.4 (3½ x ¼)	42 300	1 879 000	79	U	1644	732	411	263	183
				Du	0.15	0.34	0.60	0.94	1.35
				C	251	167	125	100	84
				Dc	0.12	0.27	0.48	0.75	1.08
89 x 9.5 (3½ x ⅜)	63 400	2 818 000	116	U	2467	1099	617	395	275
				Du	0.15	0.34	0.60	0.94	1.35
				C	376	251	188	151	126
				Dc	0.12	0.27	0.48	0.75	1.08
102 x 6.4 (4 x ¼)	55 200	2 804 000	89	U	2148	957	537	344	239
				Du	0.13	0.30	0.53	0.82	1.18
				C	328	219	164	131	109
				Dc	0.11	0.24	0.42	0.66	0.94
102 x 9.5 (4 x ⅜)	82 800	4 206 000	131	U	3222	1435	805	516	359
				Du	0.13	0.30	0.53	0.82	1.18
				C	491	328	246	197	164
				Dc	0.11	0.24	0.42	0.66	0.95
114 x 6.4 (4½ x ¼)	69 900	3 993 000	100	U	2718	1211	680	436	303
				Du	0.12	0.26	0.47	0.73	1.05
				C	415	277	207	166	138
				Dc	0.09	0.21	0.37	0.58	0.84
114 x 9.5 (4½ x ⅜)	104 800	5 989 000	147	U	4078	1816	1019	653	454
				Du	0.12	0.26	0.47	0.73	1.05
				C	622	415	311	249	208
				Dc	0.09	0.21	0.37	0.58	0.84
127 x 6.4 (5 x ¼)	86 300	5 477 000	110	U	3356	1495	839	538	374
				Du	0.11	0.24	0.42	0.66	0.95
				C	512	342	256	205	171
				Dc	0.08	0.19	0.34	0.53	0.76
127 x 9.5 (5 x ⅜)	129 400	8 216 000	163	U	5034	2242	1258	806	561
				Du	0.11	0.24	0.42	0.66	0.95
				C	768	512	384	307	256
				Dc	0.08	0.19	0.34	0.52	0.76

NOTE: When serrated grating is specified, the depth of grating required for specific load will be the next depth greater than that shown in these tables.

Loads above DO NOT include the dead load of the grating.

**STATIC  
LOAD  
TABLES  
(METRIC)**

**(Chart begins on page 55)**

U—Uniform Load, kPa		C—Concentrated Load, N/mm of Width						D—Deflection,mm	
Span in Millimeters									
1067	1219	1372	1524	1676	1829	1981	2134	2286	2438
69	53	41	34	28	23	20	17	15	13
2.59	3.39	4.21	5.32	6.40	7.46	8.93	10.22	11.87	13.31
37	32	28	26	23	21	20	18	17	16
2.08	2.69	3.35	4.27	5.02	5.96	7.21	8.11	9.42	10.75
103	79	62	50	42	35	30	26	22	20
2.58	3.37	4.24	5.21	6.40	7.57	8.93	10.42	11.61	13.65
55	48	43	38	35	32	30	27	26	24
2.07	2.69	3.43	4.16	5.09	6.05	7.21	8.11	9.60	10.75
99	76	60	48	40	34	29	25	22	19
2.15	2.81	3.57	4.34	5.29	6.38	7.49	8.70	10.08	11.26
53	46	41	37	34	31	28	26	25	23
1.73	2.24	2.84	3.51	4.30	5.09	5.84	6.78	8.02	8.94
148	113	90	73	60	50	43	37	32	28
2.15	2.79	3.57	4.40	5.29	6.26	7.41	8.58	9.77	11.06
79	69	61	55	50	46	43	39	37	35
1.72	2.24	2.82	3.48	4.21	5.04	5.98	6.78	7.91	9.07
134	103	81	66	54	46	39	34	29	26
1.83	2.40	3.03	3.76	4.50	5.44	6.34	7.45	8.37	9.70
72	63	56	50	46	42	39	36	33	31
1.48	1.93	2.44	2.99	3.66	4.34	5.12	5.91	6.66	7.59
202	154	122	99	82	69	58	50	44	39
1.84	2.39	3.04	3.76	4.56	5.44	6.29	7.30	8.46	9.70
108	94	84	75	68	63	58	54	50	47
1.48	1.92	2.44	2.99	3.61	4.34	5.08	5.91	6.73	7.67
175	134	106	86	71	60	51	44	38	34
1.61	2.09	2.66	3.28	3.96	4.75	5.56	6.46	7.34	8.50
94	82	73	66	60	55	50	47	44	41
1.29	1.68	2.13	2.64	3.20	3.81	4.40	5.17	5.95	6.73
263	202	159	129	107	90	76	66	57	50
1.61	2.10	2.66	3.28	3.98	4.75	5.52	6.46	7.34	8.33
140	123	109	98	89	82	76	70	66	61
1.28	1.68	2.12	2.62	3.16	3.79	4.46	5.13	5.95	6.67
222	170	134	109	90	76	64	56	48	43
1.43	1.87	2.36	2.92	3.53	4.23	4.90	5.77	6.51	7.55
118	104	92	83	75	69	64	59	55	52
1.14	1.50	1.89	2.34	2.81	3.36	3.96	4.56	5.22	5.99
333	255	202	163	135	113	97	83	73	64
1.43	1.87	2.37	2.91	3.53	4.19	4.95	5.70	6.61	7.49
178	156	138	124	113	104	96	89	83	78
1.15	1.50	1.89	2.33	2.82	3.37	3.96	4.59	5.26	5.99
274	210	166	134	111	93	80	69	60	53
1.29	1.68	2.13	2.62	3.17	3.77	4.46	5.18	5.94	6.78
146	128	114	102	93	85	79	73	68	64
1.03	1.34	1.71	2.09	2.54	3.01	3.56	4.11	4.71	5.38
411	315	249	202	167	140	119	103	90	79
1.29	1.68	2.13	2.63	3.18	3.78	4.43	5.16	5.94	6.74
219	192	171	154	140	128	118	110	102	96
1.03	1.34	1.71	2.11	2.55	3.03	3.55	4.13	4.71	5.38

\*Weight depends on panel width, cross bar selection, mill tolerance and manufacturing tolerance.

Loads above DO NOT include the dead load of the grating.

**STATIC  
LOAD  
TABLES  
(METRIC)**
**R-37-5 HEAVY DUTY RIVETED STEEL GRATING**

(Chart continues on page 58)

No. of Bearing bars/ Ft of Width = No. of Connecting bars/ Ft of Width = 4.683 for b = 1/4" & 4.465 for b = 3/8"				Allowable Fiber Stress					137.9 MPa
No. of Bearing bars/ M of Width = No. of Connecting bars/ M of Width = 15.36 for b = 1/4" & 14.65 for b = 3/8"									
U—Uniform Load, kPa			C—Concentrated Load, N/mm of width					D—Deflection, mm	
Bearing Bar Size mm (inches)	Section Modulus per. ft.(304.8mm) width	Moment Inertia	Approx. Wt*(Kg)/ Sq. meter	Span in Millimeters					
					305	457	610	762	914
51 x 6.4 (2 x 1/4)	16,240	449,613	71	U	633	281	158	101	70
				Du	0.241	0.542	0.964	1.507	2.170
				C	96	64	48	39	32
				Dc	0.193	0.434	0.771	1.205	1.736
51 x 9.5 (2 x 3/8)	21,612	586,387	87	U	842	374	210	135	94
				Du	0.246	0.553	0.984	1.537	2.214
				C	128	86	64	51	43
				Dc	0.197	0.443	0.787	1.230	1.771
57 x 6.4 (2 1/4 x 1/4)	19,425	616,772	77	U	757	336	189	121	84
				Du	0.210	0.473	0.841	1.314	1.892
				C	115	77	58	46	38
				Dc	0.168	0.378	0.673	1.051	1.513
57 x 9.5 (2 1/4 x 3/8)	26,316	814,690	95	U	1,025	456	256	164	114
				Du	0.216	0.485	0.862	1.347	1.940
				C	156	104	78	62	52
				Dc	0.172	0.388	0.690	1.078	1.552
64 x 6.4 (2 1/2 x 1/4)	23,306	831,839	83	U	908	404	227	145	101
				Du	0.187	0.421	0.748	1.169	1.683
				C	138	92	69	55	46
				Dc	0.150	0.337	0.598	0.935	1.346
64 x 9.5 (2 1/2 x 3/8)	31,891	1,106,010	102	U	1,242	552	311	199	138
				Du	0.192	0.433	0.770	1.203	1.732
				C	189	126	95	76	63
				Dc	0.154	0.346	0.616	0.962	1.386
76 x 6.4 (3 x 1/4)	32,872	1,423,511	94	U	1,281	569	320	205	142
				Du	0.154	0.347	0.616	0.963	1.387
				C	195	130	98	78	65
				Dc	0.123	0.277	0.493	0.771	1.110
76 x 9.5 (3 x 3/8)	45,368	1,901,345	117	U	1,767	786	442	283	196
				Du	0.159	0.358	0.637	0.995	1.433
				C	269	180	135	108	90
				Dc	0.127	0.287	0.510	0.796	1.147
89 x 6.4 (3 1/2 x 1/4)	44,617	2,258,805	105	U	1,738	773	435	278	193
				Du	0.132	0.297	0.527	0.824	1.186
				C	265	177	132	106	88
				Dc	0.105	0.237	0.422	0.659	0.949
89 x 9.5 (3 1/2 x 3/8)	61,687	3,018,552	132	U	2,403	1,068	601	385	267
				Du	0.136	0.307	0.546	0.852	1.228
				C	366	244	183	146	122
				Dc	0.109	0.246	0.436	0.682	0.982

NOTE: When serrated grating is specified, the depth of grating required for a specific load will be the next greater depth than that shown in these tables.

Loads above DO NOT include the dead load of the grating.



**STATIC  
LOAD  
TABLES  
(METRIC)**

(Chart begins on page 57)

U—Uniform Load, kPa			C—Concentrated Load, N/mm of Width				D—Deflection,mm	
Span in Millimeters								
1067	1219	1372	1524	1676	1829	1981	2134	2438
52	40	31	25	21	18	15	13	10
2.953	3.857	4.881	6.027	7.292	8.678	10.185	11.812	15.428
28	24	21	19	18	16	15	14	12
2.362	3.086	3.905	4.821	5.834	6.943	8.148	9.450	12.342
69	53	42	34	28	23	20	17	13
3.013	3.936	4.981	6.150	7.441	8.855	10.393	12.053	15.743
37	32	29	26	23	21	20	18	16
2.411	3.149	3.985	4.920	5.953	7.084	8.314	9.642	12.594
62	47	37	30	25	21	18	15	12
2.575	3.363	4.257	5.255	6.359	7.567	8.881	10.300	13.453
33	29	26	23	21	19	18	16	14
2.060	2.691	3.405	4.204	5.087	6.054	7.105	8.240	10.762
84	64	51	41	34	28	24	21	16
2.641	3.449	4.366	5.390	6.521	7.761	9.108	10.564	13.797
45	39	35	31	28	26	24	22	20
2.113	2.759	3.492	4.312	5.217	6.209	7.287	8.451	11.038
74	57	45	36	30	25	21	19	14
2.291	2.992	3.787	4.675	5.656	6.732	7.900	9.162	11.967
40	35	31	28	25	23	21	20	17
1.832	2.393	3.029	3.740	4.525	5.385	6.320	7.330	9.574
101	78	61	50	41	35	29	25	19
2.357	3.079	3.897	4.811	5.821	6.928	8.131	9.430	12.316
54	47	42	38	34	32	29	27	24
1.886	2.463	3.118	3.849	4.657	5.542	6.505	7.544	9.853
105	80	63	51	42	36	30	26	20
1.888	2.466	3.121	3.853	4.662	5.548	6.512	7.552	9.864
56	49	43	39	35	33	30	28	24
1.510	1.973	2.497	3.082	3.730	4.439	5.209	6.042	7.891
144	110	87	71	58	49	42	36	28
1.951	2.548	3.225	3.981	4.817	5.733	6.728	7.803	10.192
77	67	60	54	49	45	41	38	34
1.561	2.038	2.580	3.185	3.854	4.586	5.383	6.243	8.154
142	109	86	70	57	48	41	35	27
1.615	2.109	2.670	3.296	3.988	4.746	5.570	6.460	8.437
76	66	59	53	48	44	41	38	33
1.292	1.687	2.136	2.637	3.190	3.797	4.456	5.168	6.750
196	150	119	96	79	67	57	49	38
1.671	2.182	2.762	3.410	4.126	4.910	5.763	6.683	8.729
105	92	81	73	67	61	56	52	46
1.337	1.746	2.210	2.728	3.301	3.928	4.610	5.347	6.983

Loads above DO NOT include the dead load of the grating.

**R-37-5 HEAVY DUTY RIVETED STEEL GRATING (con't.)** (Chart continues on page 60)

No. Bars/Ft. of Width (12/Ar+b)		b=1/4" 4.683 b=3/8" 4.465		Allowable Fiber Stress		137.9 MPa			
No. Bars/Meter of Width		b=1/4" 15.36 b=3/8" 14.65		U—Uniform Load, kPa		C—Concentrated Load, N/mm of width		D—Deflection, mm	
Bearing Bar Size mm (inches)	Section Modulus per. ft.(304.8mm) width	Moment Inertia	Approx. Wt*(Kg)/ Sq. meter	Span in Millimeters					
					305	457	610	762	914
102 x 6.4 (4 x 1/4)	58,341	3,370,351	116	U	2,273	1,010	568	364	253
				Du	0.116	0.260	0.462	0.722	1.040
				C	346	231	173	139	115
				Dc	0.092	0.208	0.370	0.578	0.832
102 x 9.5 (4 x 3/8)	80,675	4,502,792	147	U	3,143	1,397	786	503	349
				Du	0.120	0.269	0.478	0.747	1.076
				C	479	319	239	192	160
				Dc	0.096	0.215	0.383	0.598	0.861
114 x 6.4 (4 1/2 x 1/4)	73,956	4,790,158	127	U	2,881	1,281	720	461	320
				Du	0.103	0.232	0.412	0.644	0.927
				C	439	293	220	176	146
				Dc	0.082	0.185	0.330	0.515	0.742
114 x 9.5 (4 1/2 x 3/8)	102,222	6,398,434	163	U	3,982	1,770	996	637	442
				Du	0.107	0.240	0.427	0.666	0.960
				C	607	405	303	243	202
				Dc	0.085	0.192	0.341	0.533	0.768
127 x 6.4 (5 x 1/4)	91,392	6,549,526	138	U	3,560	1,582	890	570	396
				Du	0.093	0.210	0.373	0.582	0.838
				C	543	362	271	217	181
				Dc	0.075	0.168	0.298	0.466	0.671
127 x 9.5 (5 x 3/8)	126,261	8,749,767	178	U	4,919	2,186	1,230	787	547
				Du	0.096	0.217	0.385	0.602	0.867
				C	750	500	375	300	250
				Dc	0.077	0.173	0.308	0.482	0.693

NOTE: When serrated grating is specified, the depth of grating required for a specific load will be the next greater depth than that shown in these tables.

Loads above DO NOT include the dead load of the grating.

**STATIC  
LOAD  
TABLES  
(METRIC)**

(Chart begins on page 59)

U—Uniform Load, kPa			C—Concentrated Load, N/mm of Width				D—Deflection,mm	
Span in Millimeters								
1067	1219	1372	1524	1676	1829	1981	2134	2438
186	142	112	91	75	63	54	46	36
1.415	1.848	2.339	2.888	3.495	4.159	4.881	5.661	7.394
99	87	77	69	63	58	53	49	43
1.132	1.479	1.872	2.311	2.796	3.327	3.905	4.529	5.915
257	196	155	126	104	87	74	64	49
1.465	1.913	2.421	2.989	3.617	4.305	5.052	5.859	7.653
137	120	106	96	87	80	74	68	60
1.172	1.531	1.937	2.392	2.894	3.444	4.042	4.687	6.122
235	180	142	115	95	80	68	59	45
1.262	1.649	2.087	2.576	3.117	3.710	4.354	5.049	6.595
125	110	98	88	80	73	68	63	55
1.010	1.319	1.669	2.061	2.494	2.968	3.483	4.039	5.276
325	249	197	159	132	111	94	81	62
1.306	1.706	2.159	2.666	3.225	3.839	4.505	5.225	6.824
173	152	135	121	110	101	93	87	76
1.045	1.365	1.727	2.133	2.580	3.071	3.604	4.180	5.459
291	223	176	142	118	99	84	73	56
1.141	1.490	1.886	2.328	2.817	3.353	3.935	4.563	5.960
155	136	121	109	99	90	83	78	68
0.913	1.192	1.509	1.863	2.254	2.682	3.148	3.651	4.768
402	307	243	197	163	137	116	100	77
1.180	1.541	1.950	2.408	2.913	3.467	4.069	4.719	6.164
214	187	167	150	136	125	115	107	94
0.944	1.233	1.560	1.926	2.331	2.774	3.255	3.775	4.931

Loads above DO NOT include the dead load of the grating.

## VEHICULAR LOAD TABLE

## W-15-4 HEAVY DUTY WELDED STEEL GRATING

Bearing Bar Size	Section Modulus per ft. of width	Moment of Inertia per ft. of width	*Approx. Weight lbs./sq. ft.	Clear Span in inches / mm													
				H-25 Load		H-20 Load		H-15 Load		Auto Traffic		5 Ton Forklift		3 Ton Forklift		1 Ton Forklift	
				inches	mm	inches	mm	inches	mm	inches	mm	inches	mm	inches	mm	inches	mm
1 x 1/4	0.533	0.267	12.0	13	330	12	304	10	254	14	355	8	203	7	177	8	203
1 x 3/8	0.800	0.400	17.4	16	406	15	381	13	330	19	482	10	254	8	203	11	279
1-1/4 x 1/4	0.833	0.521	14.7	16	406	15	381	13	330	20	508	10	254	9	228	11	279
1-1/4 x 3/8	1.250	0.781	21.5	20	508	18	457	16	406	25	635	13	330	11	279	16	406
1-1/2 x 1/4	1.200	0.900	17.4	20	508	18	457	16	406	27	685	13	330	11	279	15	381
1-1/2 x 3/8	1.800	1.350	25.6	24	609	22	558	20	508	33	838	16	406	15	381	22	558
1-3/4 x 1/4	1.633	1.429	20.2	23	584	21	533	19	482	34	863	15	381	14	355	20	508
1-3/4 x 3/8	2.450	2.144	29.7	29	736	27	685	25	635	42	1066	21	533	20	508	30	762
2 x 1/4	2.133	2.133	22.9	27	685	24	609	22	558	42	1066	19	482	17	431	26	660
2 x 3/8	3.200	3.200	33.8	34	863	32	812	30	762	51	1295	25	635	25	635	38	965
2-1/4 x 1/4	2.700	3.038	25.6	31	787	28	711	26	660	50	1270	22	558	21	533	32	812
2-1/4 x 3/8	4.050	4.556	37.8	40	1016	38	965	36	914	57	1447	31	787	30	762	47	1193
2-1/2 x 1/4	3.333	4.167	28.3	35	889	33	838	31	787	55	1397	26	660	26	660	40	1016
2-1/2 x 3/8	5.000	6.250	41.9	46	1168	45	1143	43	1092	63	1600	37	939	37	939	53	1346
3 x 1/4	4.800	7.200	33.8	45	1143	43	1092	42	1066	66	1676	36	914	36	914	56	1422
3 x 3/8	7.200	10.800	50.1	56	1422	55	1397	55	1397	76	1930	51	1295	52	1320	64	1625
3-1/2 x 1/4	6.533	11.433	39.2	57	1447	55	1397	54	1371	77	1955	47	1193	47	1193	65	1651
3-1/2 x 3/8	9.800	17.150	58.2	65	1651	64	1625	65	1651	88	2235	62	1574	63	1600	75	1905
4 x 1/4	8.533	17.067	44.6	64	1625	64	1625	64	1625	88	2235	59	1498	61	1549	75	1905
4 x 3/8	12.800	25.600	66.4	73	1854	73	1854	74	1879	96	2438	71	1803	72	1828	86	2184
4-1/2 x 1/4	10.800	24.300	50.1	74	1879	74	1879	75	1905	96	2438	72	1828	73	1854	87	2209
4-1/2 x 3/8	16.200	36.450	74.6	76	1930	76	1930	77	1955	96	2438	74	1879	75	1905	89	2260
5 x 1/4	13.333	33.333	55.5	80	2032	80	2032	81	2057	96	2438	77	1955	79	2006	93	2362
5 x 3/8	20.000	50.000	82.7	91	2311	92	2336	92	2336	96	2438	88	2235	90	2286	96	2438

Note: When serrated grating is specified, the depth of the grating required for a specific load will be the next depth greater than that shown in these tables.

\* Weight depends on panel width, cross bar selection, mill tolerance and manufacturing tolerance.

Maximum Simple Clear Spans are limited to 96 inches to avoid possibility of having two wheel loads in the same span.

Shaded area indicates Maximum Simple Clear Spans are limited by maximum allowable stress or the lesser deflection of  $L / 400$  or  $1/8"$ .

## VEHICULAR LOAD TABLE

## W-19-4 HEAVY DUTY WELDED STEEL GRATING

Bearing Bar Size	Section Modulus per ft. of width	Moment of Inertia per ft. of width	*Approx. Weight lbs./sq. ft.	Clear Span in inches / mm													
				H-25 Load		H-20 Load		H-15 Load		Auto Traffic		5 Ton Forklift		3 Ton Forklift		1 Ton Forklift	
				inches	mm	inches	mm	inches	mm	inches	mm	inches	mm	inches	mm	inches	mm
1 x 1/4	0.421	0.211	9.7	12	304	10	254	9	228	12	304	7	177	6	152	7	177
1 x 3/8	0.632	0.316	14.0	14	355	13	330	11	279	16	406	9	228	8	203	9	228
1-1/4 x 1/4	0.658	0.411	11.9	15	381	13	330	12	304	17	431	9	228	8	203	10	254
1-1/4 x 3/8	0.987	0.617	17.2	18	457	16	406	14	355	23	584	12	304	10	254	14	355
1-1/2 x 1/4	0.947	0.711	14.0	18	457	16	406	14	355	23	584	11	279	10	254	13	330
1-1/2 x 3/8	1.421	1.066	20.5	22	558	20	508	18	457	30	762	14	355	13	330	19	482
1-3/4 x 1/4	1.289	1.128	16.2	21	533	19	482	17	431	29	736	14	355	12	304	17	431
1-3/4 x 3/8	1.934	1.692	23.7	26	660	23	584	21	533	38	965	18	457	17	431	25	635
2 x 1/4	1.684	1.684	18.3	24	609	22	558	20	508	37	939	16	406	15	381	22	558
2 x 3/8	2.526	2.526	26.9	30	762	28	711	26	660	46	1168	22	558	21	533	33	838
2-1/4 x 1/4	2.132	2.398	20.5	27	685	25	635	23	584	45	1143	19	482	18	457	28	711
2-1/4 x 3/8	3.197	3.597	30.1	34	863	32	812	31	787	53	1346	26	660	26	660	41	1041
2-1/2 x 1/4	2.632	3.289	22.6	30	762	28	711	27	685	52	1320	22	558	22	558	34	863
2-1/2 x 3/8	3.947	4.934	33.3	40	1016	38	965	36	914	59	1498	31	787	31	787	50	1270
3 x 1/4	3.789	5.684	26.9	39	990	37	939	35	889	62	1574	30	762	30	762	49	1244
3 x 3/8	5.684	8.526	39.8	52	1320	50	1270	49	1244	71	1803	43	1092	44	1117	61	1549
3-1/2 x 1/4	5.158	9.026	31.2	48	1219	46	1168	45	1143	72	1828	39	990	40	1016	62	1574
3-1/2 x 3/8	7.737	13.539	46.2	60	1524	60	1524	60	1524	83	2108	56	1422	58	1473	71	1803
4 x 1/4	6.737	13.474	35.5	59	1498	58	1473	57	1447	83	2108	50	1270	51	1295	71	1803
4 x 3/8	10.105	20.211	52.7	68	1727	68	1727	69	1752	95	2413	66	1676	68	1727	81	2057
4-1/2 x 1/4	8.526	19.184	39.8	69	1752	69	1752	70	1778	96	2438	61	1549	64	1625	82	2082
4-1/2 x 3/8	12.789	28.776	59.1	71	1803	71	1803	72	1828	96	2438	69	1752	71	1803	84	2133
5 x 1/4	10.526	26.316	44.1	75	1905	75	1905	75	1905	96	2438	72	1828	74	1879	89	2260
5 x 3/8	15.789	39.474	65.5	85	2159	85	2159	86	2184	96	2438	83	2108	85	2159	96	2438

Note: When serrated grating is specified, the depth of the grating required for a specific load will be the next depth greater than that shown in these tables.

\* Weight depends on panel width, cross bar selection, mill tolerance and manufacturing tolerance.

Maximum Simple Clear Spans are limited to 96 inches to avoid possibility of having two wheel loads in the same span.

Shaded area indicates Maximum Simple Clear Spans are limited by maximum allowable stress or the lesser deflection of  $L / 400$  or  $1/8''$ .



## VEHICULAR LOAD TABLE

## W-22-4 HEAVY DUTY WELDED STEEL GRATING

Bearing Bar Size	Section Modulus per ft. of width	Moment of Inertia per ft. of width	*Approx. Weight lbs./sq. ft.	Clear Span in inches / mm													
				H-25 Load		H-20 Load		H-15 Load		Auto Traffic		5 Ton Forklift		3 Ton Forklift		1 Ton Forklift	
				inches	mm	inches	mm	inches	mm	inches	mm	inches	mm	inches	mm	inches	mm
1 x 1/4	0.364	0.182	8.5	11	279	10	254	9	228	11	279	7	177	6	152	6	152
1 x 3/8	0.545	0.273	12.3	13	330	12	304	11	279	15	381	9	228	7	177	9	228
1-1/4 x 1/4	0.568	0.355	10.4	14	355	12	304	11	279	16	406	9	228	7	177	9	228
1-1/4 x 3/8	0.852	0.533	15.0	17	431	15	381	13	330	21	533	11	279	9	228	13	330
1-1/2 x 1/4	0.818	0.614	12.3	17	431	15	381	13	330	21	533	11	279	9	228	12	304
1-1/2 x 3/8	1.227	0.920	17.8	20	508	18	457	16	406	29	736	13	330	12	304	18	457
1-3/4 x 1/4	1.114	0.974	14.1	20	508	18	457	15	381	27	685	13	330	11	279	16	406
1-3/4 x 3/8	1.670	1.462	20.6	24	609	22	558	20	508	36	914	16	406	15	381	23	584
2 x 1/4	1.455	1.455	16.0	22	558	20	508	18	457	34	863	15	381	14	355	21	533
2 x 3/8	2.182	2.182	23.4	28	711	25	635	24	609	44	1117	20	508	19	482	30	762
2-1/4 x 1/4	1.841	2.071	17.8	25	635	23	584	21	533	41	1041	18	457	17	431	26	660
2-1/4 x 3/8	2.761	3.107	26.2	32	812	30	762	28	711	51	1295	24	609	24	609	38	965
2-1/2 x 1/4	2.273	2.841	19.7	28	711	26	660	24	609	50	1270	20	508	20	508	31	787
2-1/2 x 3/8	3.409	4.261	28.9	36	914	34	863	33	838	57	1447	28	711	28	711	46	1168
3 x 1/4	3.273	4.909	23.4	35	889	33	838	32	812	60	1524	27	685	27	685	44	1117
3 x 3/8	4.909	7.364	34.5	47	1193	45	1143	44	1117	68	1727	38	965	40	1016	59	1498
3-1/2 x 1/4	4.455	7.795	27.1	44	1117	42	1066	41	1041	70	1778	35	889	36	914	60	1524
3-1/2 x 3/8	6.682	11.693	40.1	58	1473	58	1473	58	1473	80	2032	50	1270	53	1346	69	1752
4 x 1/4	5.818	11.636	30.8	53	1346	52	1320	51	1295	80	2032	45	1143	46	1168	69	1752
4 x 3/8	8.727	17.455	45.6	66	1676	66	1676	66	1676	91	2311	63	1600	65	1651	79	2006
4-1/2 x 1/4	7.364	16.568	34.5	64	1625	63	1600	63	1600	92	2336	55	1397	58	1473	80	2032
4-1/2 x 3/8	11.045	24.852	51.2	69	1752	69	1752	69	1752	94	2387	66	1676	68	1727	82	2082
5 x 1/4	9.091	22.727	38.2	71	1803	72	1828	72	1828	96	2438	67	1701	71	1803	86	2184
5 x 3/8	13.636	34.091	56.8	81	2057	82	2082	82	2082	96	2438	79	2006	82	2082	96	2438

Note: When serrated grating is specified, the depth of the grating required for a specific load will be the next depth greater than that shown in these tables.

\* Weight depends on panel width, cross bar selection, mill tolerance and manufacturing tolerance.

Maximum Simple Clear Spans are limited to 96 inches to avoid possibility of having two wheel loads in the same span.

Shaded area indicates Maximum Simple Clear Spans are limited by maximum allowable stress or the lesser deflection of  $L / 400$  or  $1/8"$ .

## VEHICULAR LOAD TABLE

## W-30-4 HEAVY DUTY WELDED STEEL GRATING

Bearing Bar Size	Section Modulus per ft. of width	Moment of Inertia per ft. of width	*Approx. Weight lbs./sq. ft.	Clear Span in inches / mm													
				H-25 Load		H-20 Load		H-15 Load		Auto Traffic		5 Ton Forklift		3 Ton Forklift		1 Ton Forklift	
				inches	mm	inches	mm	inches	mm	inches	mm	inches	mm	inches	mm	inches	mm
1 x 1/4	0.267	0.133	6.6	9	228	9	228	8	203	10	254	6	152	5	127	6	152
1 x 3/8	0.400	0.200	9.3	12	304	11	279	9	228	13	330	8	203	6	152	8	203
1-1/4 x 1/4	0.417	0.260	7.9	12	304	11	279	10	254	13	330	8	203	6	152	8	203
1-1/4 x 3/8	0.625	0.391	11.3	15	381	13	330	12	304	18	457	10	254	8	203	11	279
1-1/2 x 1/4	0.600	0.450	9.3	14	355	13	330	12	304	17	431	9	228	8	203	11	279
1-1/2 x 3/8	0.900	0.675	13.4	18	457	16	406	14	355	24	609	12	304	10	254	15	381
1-3/4 x 1/4	0.817	0.715	10.6	17	431	15	381	14	355	22	558	11	279	10	254	14	355
1-3/4 x 3/8	1.225	1.072	15.4	21	533	19	482	17	431	31	787	14	355	13	330	20	508
2 x 1/4	1.067	1.067	12.0	19	482	18	457	16	406	27	685	13	330	12	304	18	457
2 x 3/8	1.600	1.600	17.4	24	609	22	558	20	508	39	990	17	431	16	406	26	660
2-1/4 x 1/4	1.350	1.519	13.4	22	558	20	508	18	457	34	863	15	381	14	355	22	558
2-1/4 x 3/8	2.025	2.278	19.5	27	685	25	635	23	584	47	1193	20	508	20	508	32	812
2-1/2 x 1/4	1.667	2.083	14.7	24	609	22	558	20	508	41	1041	17	431	17	431	27	685
2-1/2 x 3/8	2.500	3.125	21.5	30	762	29	736	27	685	53	1346	23	584	24	609	39	990
3 x 1/4	2.400	3.600	17.4	30	762	28	711	26	660	55	1397	23	584	23	584	38	965
3 x 3/8	3.600	5.400	25.6	39	990	37	939	36	914	63	1600	31	787	33	838	56	1422
3-1/2 x 1/4	3.267	5.717	20.2	36	914	34	863	33	838	65	1651	29	736	30	762	51	1295
3-1/2 x 3/8	4.900	8.575	29.7	48	1219	47	1193	46	1168	74	1879	41	1041	43	1092	65	1651
4 x 1/4	4.267	8.533	22.9	43	1092	42	1066	41	1041	74	1879	36	914	38	965	65	1651
4 x 3/8	6.400	12.800	33.8	59	1498	58	1473	58	1473	85	2159	52	1320	56	1422	74	1879
4-1/2 x 1/4	5.400	12.150	25.6	52	1320	51	1295	50	1270	86	2184	44	1117	47	1193	75	1905
4-1/2 x 3/8	8.100	18.225	37.8	72	1828	71	1803	72	1828	88	2235	64	1625	69	1752	77	1955
5 x 1/4	6.667	16.667	28.3	61	1549	60	1524	60	1524	92	2336	54	1371	58	1473	81	2057
5 x 3/8	10.000	25.000	41.9	75	1905	75	1905	76	1930	96	2438	73	1854	76	1930	93	2362

Note: When serrated grating is specified, the depth of the grating required for a specific load will be the next depth greater than that shown in these tables.

\* Weight depends on panel width, cross bar selection, mill tolerance and manufacturing tolerance.

Maximum Simple Clear Spans are limited to 96 inches to avoid possibility of having two wheel loads in the same span.

Shaded area indicates Maximum Simple Clear Spans are limited by maximum allowable stress or the lesser deflection of  $L / 400$  or  $1/8"$ .

## VEHICULAR LOAD TABLE

## W-38-4 HEAVY DUTY WELDED STEEL GRATING

Bearing Bar Size	Section Modulus per ft. of width	Moment of Inertia per ft. of width	*Approx. Weight lbs./sq. ft.	Clear Span in inches / mm													
				H-25 Load		H-20 Load		H-15 Load		Auto Traffic		5 Ton Forklift		3 Ton Forklift		1 Ton Forklift	
				inches	mm	inches	mm	inches	mm	inches	mm	inches	mm	inches	mm	inches	mm
1 x 1/4	0.211	0.105	5.4	8	203	8	203	7	177	9	228	6	152	5	127	5	127
1 x 3/8	0.316	0.158	7.6	10	254	10	254	8	203	11	279	7	177	6	152	7	177
1-1/4 x 1/4	0.329	0.206	6.5	11	279	10	254	9	228	12	304	8	203	6	152	7	177
1-1/4 x 3/8	0.493	0.308	9.2	13	330	12	304	11	279	16	406	9	228	7	177	10	254
1-1/2 x 1/4	0.474	0.355	7.6	13	330	12	304	10	254	15	381	9	228	7	177	10	254
1-1/2 x 3/8	0.711	0.533	10.8	16	406	15	381	13	330	21	533	11	279	9	228	14	355
1-3/4 x 1/4	0.645	0.564	8.6	16	406	14	355	12	304	19	482	10	254	9	228	12	304
1-3/4 x 3/8	0.967	0.846	12.4	19	482	17	431	15	381	27	685	13	330	12	304	18	457
2 x 1/4	0.842	0.842	9.7	17	431	16	406	14	355	24	609	12	304	11	279	16	406
2 x 3/8	1.263	1.263	14.0	21	533	20	508	18	457	34	863	15	381	14	355	23	584
2-1/4 x 1/4	1.066	1.199	10.8	20	508	18	457	16	406	29	736	13	330	13	330	20	508
2-1/4 x 3/8	1.599	1.799	15.6	24	609	22	558	20	508	42	1066	17	431	17	431	29	736
2-1/2 x 1/4	1.316	1.645	11.9	22	558	20	508	18	457	35	889	15	381	15	381	24	609
2-1/2 x 3/8	1.974	2.467	17.2	27	685	25	635	24	609	50	1270	20	508	21	533	35	889
3 x 1/4	1.895	2.842	14.0	26	660	25	635	23	584	49	1244	20	508	20	508	34	863
3 x 3/8	2.842	4.263	20.5	34	863	32	812	31	787	60	1524	27	685	29	736	50	1270
3-1/2 x 1/4	2.579	4.513	16.2	32	812	30	762	29	736	61	1549	25	635	26	660	45	1143
3-1/2 x 3/8	3.868	6.770	23.7	42	1066	40	1016	40	1016	70	1778	35	889	38	965	63	1600
4 x 1/4	3.368	6.737	18.3	38	965	36	914	35	889	70	1778	31	787	33	838	59	1498
4 x 3/8	5.053	10.105	26.9	51	1295	50	1270	50	1270	80	2032	44	1117	48	1219	72	1828
4-1/2 x 1/4	4.263	9.592	20.5	45	1143	43	1092	43	1092	81	2057	38	965	41	1041	73	1854
4-1/2 x 3/8	6.395	14.388	30.1	61	1549	60	1524	61	1549	83	2108	55	1397	60	1524	75	1905
5 x 1/4	5.263	13.158	22.6	52	1320	51	1295	51	1295	88	2235	46	1168	50	1270	78	1981
5 x 3/8	7.895	19.737	33.3	70	1778	70	1778	71	1803	96	2438	66	1676	72	1828	90	2286

Note: When serrated grating is specified, the depth of the grating required for a specific load will be the next depth greater than that shown in these tables.

\* Weight depends on panel width, cross bar selection, mill tolerance and manufacturing tolerance.

Maximum Simple Clear Spans are limited to 96 inches to avoid possibility of having two wheel loads in the same span.

Shaded area indicates Maximum Simple Clear Spans are limited by maximum allowable stress or the lesser deflection of  $L / 400$  or  $1/8"$ .

## VEHICULAR LOAD TABLE

## R-37-5 HEAVY DUTY RIVETED STEEL GRATING

Bearing Bar Size	Section Modulus per ft. of width	Moment of Inertia per ft. of width	*Approx. Weight lbs./sq. ft.	Clear Span in inches / mm													
				H-25 Load		H-20 Load		H-15 Load		Auto Traffic		5 Ton Forklift		3 Ton Forklift		1 Ton Forklift	
				inches	mm	inches	mm	inches	mm	inches	mm	inches	mm	inches	mm	inches	mm
2 x 1/4	0.991	1.080	14.6	20	508	18	457	16	406	28	711	13	330	12	304	19	482
2 x 3/8	1.319	1.409	17.9	23	584	21	533	19	482	36	914	16	406	16	406	25	635
2-1/4 x 1/4	1.185	1.482	15.7	22	558	19	482	17	431	33	838	15	381	14	355	22	558
2-1/4 x 3/8	1.606	1.957	19.4	25	635	23	584	21	533	44	1117	18	457	18	457	30	762
2-1/2 x 1/4	1.422	1.999	17.0	23	584	21	533	20	508	38	965	17	431	16	406	26	660
2-1/2 x 3/8	1.946	2.657	20.8	28	711	26	660	24	609	52	1320	21	533	22	558	37	939
3 x 1/4	2.006	3.420	19.3	28	711	26	660	25	635	53	1346	21	533	22	558	37	939
3 x 3/8	2.769	4.568	24.0	34	863	32	812	31	787	62	1574	28	711	29	736	51	1295
3-1/2 x 1/4	2.723	5.427	21.5	33	838	32	812	31	787	65	1651	27	685	28	711	49	1244
3-1/2 x 3/8	3.764	7.252	27.1	42	1066	40	1016	40	1016	72	1828	36	914	38	965	65	1651
4 x 1/4	3.560	8.097	23.8	40	1016	38	965	38	965	74	1879	33	838	36	914	63	1600
4 x 3/8	4.923	10.818	30.2	51	1295	50	1270	50	1270	82	2082	45	1143	49	1244	74	1879
4-1/2 x 1/4	4.513	11.508	26.0	47	1193	46	1168	46	1168	83	2108	41	1041	44	1117	74	1879
4-1/2 x 3/8	6.238	15.372	33.3	60	1524	60	1524	61	1549	93	2362	55	1397	61	1549	83	2108
5 x 1/4	5.577	15.735	28.3	55	1397	54	1371	55	1397	93	2362	49	1244	54	1371	83	2108
5 x 3/8	7.705	21.021	36.5	71	1803	72	1828	73	1854	96	2438	67	1701	74	1879	92	2336

\* Weight depends on panel width, cross bar selection, mill tolerance and manufacturing tolerance.

Connecting bars size = 3/16" x 1-1/2" in all cases.

Maximum Simple Clear Spans are limited to 96 inches to avoid possibility of having two wheel loads in the same span.

Shaded area indicates Maximum Simple Clear Spans are limited by maximum allowable stress or the lesser deflection of  $L / 400$  or  $1/8"$ .

## GLOSSARY OF TERMS

Commonly used in the Industry

**ANCHOR** — A device by which grating is attached to its supports.

**BAND** — A flat welded to a side or end of a grating panel, or along the line of a cutout, and extending neither above nor below the bearing bars.

**BEARING BARS** — Load-carrying members extending in the direction of the grating span.

**BEARING BAR CENTERS** — The distance center-to-center of the bearing bars.

**CLEAR OPENING** — The distance between faces of bearing bars in a rectangular grating, or between a reticuline bar and a bearing bar in a riveted grating.

**CROSS BARS** — The connecting bars which extend across the bearing bars, usually perpendicular to them. They may be bent into a corrugated or sinuous pattern and, where they intersect the bearing bars, are welded, forged or mechanically locked to them.

**CROSS BAR CENTERS** — The distance center-to-center of the cross bars.

**CURVED CUT** — A cutout following a curved pattern.

**CUTOUT** — An area of grating removed to clear an obstruction or to permit pipes, ducts, columns, etc. to pass through the grating.

**FINISH** — The coating, usually paint or galvanizing, which is applied to the grating.

**GRATING** — An open grid assembly of metal bars, in which the bearing bars, running in one direction, are spaced by rigid attachment to cross bars running perpendicular to them or by reticuline bars extending between them.

**HINGED PANELS** — Grating panels which are hinged to their supports or to other grating parts.

**LENGTH** — Refer to Span of Grating.

**LOAD-CARRYING BAND** — A band used to transfer the load between bearing bars.

**METRIC** — The system of metric measurement used is from IEEE/ASTM SI 10-2002, "Standard for Use of the International System of Units (SI): The Modern Metric System"

**PRESSURE-LOCKED GRATING** — Grating in which the cross bars are mechanically locked to the bearing bars at their intersections by deforming or swaging the metal.

**RETICULINE BAR** — A sinuously bent connecting bar extending between two adjacent bearing bars, alternately contacting and being riveted to each.

**REVERSIBLE GRATING** — Grating so constructed that it may be installed either side up, with no difference in appearance or carrying capacity.

**RIVET CENTERS** — The distance center-to-center of rivets along one bearing bar.

**RIVETED GRATING** — Grating composed of straight bearing bars and reticuline bars, which are joined, at their contact points, by riveting.

**SERRATED GRATING** — Grating which has the top surfaces of the bearing bars or cross bars, or both, notched.

**SPAN OF GRATING** — The distance between points of grating support, or the dimension of the bearing bars in this direction.

**STRAIGHT CUT** — That portion of the cut edge or cutout of a grating which follows a straight line.

**SWAGING** — A method of altering the cross-sectional shape of a metal bar by pressure applied through dies.

**TOE PLATE** — A flat bar attached flat against the outer edge of a grating and projecting above the top surface of the grating to form a lip or curb.

**WELDED GRATING** — Grating in which the bearing bars and the cross bars are joined at all of their intersections by either a resistance weld or conventional hand welding. A resistance weld is obtained by the heat produced by the resistance of the material to the flow of electric current causing the material to become plastic. At this point the pressure on the cross bar is rapidly increased causing the cross bar to penetrate the bearing bar so that they are fused together.

**WIDTH** — The overall dimension of grating panel, measured perpendicular to the bearing bars.