

**HOLLOW
METAL
MANUAL**

AMERICAN NATIONAL STANDARD

**ANSI/
NAAMM**

HMMA 840 - 16

08 11 13 Hollow Metal Doors and Frames

**GUIDE SPECIFICATION
FOR RECEIPT, STORAGE
AND INSTALLATION
OF HOLLOW METAL
DOORS AND FRAMES**

FIRST ADDITION

xxxxxxx xx, 20xx



Hollow Metal Manufacturers Association

Division of the National Association of Architectural Metal Manufacturers

Approval of an American National Standard requires verification by ANSI that the requirements for due process, consensus, and other criteria for approval have been met by the standards developer.

Consensus is established when, in the judgment of the ANSI Board of Standards Review, substantial agreement has been reached by directly and materially affected interests. Substantial agreement means much more than a simple majority, but not necessarily unanimity. Consensus requires that all views and objections be considered, and that a concerted effort be made toward their resolution.

The use of American National Standards is completely voluntary; their existence does not in any respect preclude anyone, whether they have approved the standards or not, from manufacturing, marketing, purchasing, or using products, processes, or procedures not conforming to the standards.

The American National Standards Institute does not develop standards and will in no circumstances give an interpretation of any American National Standard. Moreover, no person has the right or authority to issue an interpretation of an American National Standard in the name of the American National Standards Institute. Requests for interpretation should be addressed to the sponsor whose name appears on the title page of this standard.

CAUTION NOTICE: This American National Standard can be revised or withdrawn at any time. The procedures of the American National Standards Institute require that action be taken periodically to reaffirm, revise, or withdraw this standard. Purchasers of American National Standards can receive current information on all standards by calling or writing the American National Standards Institute.

This standard was developed by representative members of the Hollow Metal Manufacturers Association Division (HMMA) of the National Association of Architectural Metal Manufacturers (NAAMM) to provide information and guidance on the installation and storage for hollow metal doors and frames. This standard contains advisory information only and is published as a public service by NAAMM and its HMMA Division.

NAAMM AND ITS HMMA DIVISION DISCLAIM ALL LIABILITY OF ANY KIND FOR THE USE, APPLICATION OR ADAPTATION OF MATERIAL PUBLISHED IN THIS STANDARD.

Current information on all NAAMM Standards is available by calling, writing, or visiting the website of the National Association of Architectural Metal Manufacturers, www.naamm.org.

National Association of Architectural Metal Manufacturers

800 Roosevelt Road, Building C, Suite 312, Glen Ellyn, Illinois 60137
Tel: 1-630-942-6591 • Fax: 1-639-790-3095 • Website: www.naamm.org

Copyright © _____

All Rights Reserved

TABLE OF CONTENTS

PART 1.	GENERAL	2
1.01	INTRODUCTION.....	2
1.02	RELATED DOCUMENTS	2
PART 2.	RECEIVING AND STORAGE OF MATERIAL	2
2.01	RECEIVING MATERIAL	3
2.02	ON SITE STORAGE	3
PART 3.	INSTALLATION OF FRAMES	4
3.01	GENERAL	4
3.02	PRIOR TO INSTALLATION	5
3.03	INSTALLATION TOLERANCES	5
3.04	TYPICAL INSTALLATION PROCEDURES	7
3.05	FLOOR ANCHORS	11
3.06	WALL CONSTRUCTION AND APPROPRIATE ANCHORS	12
3.06.01	MASONRY WALLS	13
3.06.02	STEEL STUD WALLS	15
3.06.03	WOOD STUD WALLS.....	17
3.06.04	EXISTING MASONRY WALLS	19
3.06.05	POURED IN PLACE OR TILT UP CONCRETE WALLS	20
3.06.06	COMPLETED DRY WALL	21
3.07	GROUTING OF FRAMES	23
3.08	FIELD SPLICING	23
PART 4.	HANGING OF DOORS	24
4.01	GENERAL	24
4.02	OPERATIONAL CLEARANCES	25
4.03	CARE AFTER INSTALLATION	25
PART 5.	APPENDIX	A1
5.01	GROUTING OF HOLLOW METAL FRAMES	A1
5.02	DEFINING UNDERCUTS	A2
5.03	PAINTING HOLLOW METAL PRODUCTS	A4

PART I- GENERAL

1.01 INTRODUCTION

The purpose of this guide specification is to describe the essential requirements for the receipt, storage, handling and installation of hollow metal door and frame products. Proper installation of the product is as important as the quality of the manufacturing.

The installation of doors and frames is a trade demanding care and skill if the assembly is to operate and perform properly. Care in manufacturing does not, in itself, guarantee satisfactory performance. Even the best designed and most carefully constructed doors and frames will not function properly if installed incorrectly.

The hollow metal manufacturer is a material supplier, not a subcontractor. The manufacturer does not provide for the installation of their product in the building, but only shipment in good condition from the factory.

It is essential that material is properly stored prior to installation and good installation skills are exercised in the setting of frames and hanging of doors. Should a problem occur most member companies of the Hollow Metal Manufacturer's Association Division of NAAMM have their own field representatives who are qualified not only to do expert repair work but to determine whether the fault lies with the manufacturer or with some other party.

1.02 RELATED DOCUMENTS

The documents listed are referenced by basic designation only. The edition of a document is deemed to be that in effect on the publication date of this document, unless noted otherwise. If a more recent document is available the specifier should verify its applicability to this standard prior to inclusion.

- A. ANSI/SDI A.250.11 Recommended Erection Instructions for Steel Frames
- B. ANSI/NAAMM HMMA 801 Glossary of Terms for Hollow Metal Doors and Frames
- C. ANSI/NAAMM HMMA 841 Tolerances and Clearances for Commercial Hollow Metal Doors and Frames
- D. NAAMM HMMA 820 Hollow Metal Frames
- E. NFPA 80 Standard for Fire Doors and Other Opening Protectives
- F. SDI-122 Installation & Troubleshooting for Standard Steel Doors and Frames
- G. HMMA-820 TN01-03 Grouting Hollow Metal Frames
- H. HMMA-810 TN01-03 Defining Undercuts
- I. HMMA-840 TN01-07 Painting Hollow Metal Products

PART 2 - RECEIVING AND STORAGE OF MATERIAL

2.01 RECEIVING MATERIAL

Upon delivery, hollow metal products must be thoroughly inspected for damage by the receiving party able to judge acceptability and who has the authority to sign for the materials acceptability. When provided, follow the manufacturer's instructions for receiving material. Cardboard and other wrappings are to be removed for inspection. In all cases damaged product deemed to be unacceptable, must be noted on the Bill of Lading. Claims of freight damage will not be honored by the freight carrier unless the damaged items are noted on the Bill of Lading at the time of delivery. In addition the hollow metal supplier must also be notified immediately, in writing, so that the supplier and manufacturer can participate in recommending the best course of action. Under no circumstances should material be refused without contacting the party responsible for shipping the material. When material is damaged the freight carrier must be requested to do an inspection of the damage. This procedure will help expedite the repair or replacement of the damaged items and the processing of the damage claim with the freight carrier.

During shipping and handling minor surface scratches and/or scuffing may occur. These areas must be promptly cleaned, finished smooth and touched up by the receiving party with a direct to metal (DTM) rust inhibitive primer. Touching up damaged areas with DTM primer that is comparable to the manufacturers and compatible with the finish paint specified will prevent rusting and maximize finish paint adhesion.

2.02 ON SITE STORAGE

Proper storage of hollow metal products at the construction site will prevent damage. Cardboard and other wrappings are to be removed to promote air circulation. Steel products that have not been finished painted must be protected from exposure to conditions such as high humidity, salt air, rain, snow, etc. The factory applied primer on steel products is porous to properly receive and hold finish paint. Water or moisture in contact with primer coated steel will seep through to the steel. An electrolytic action then follows, resulting in corrosion and causing the paint film to lose adhesion. The presence of oxygen at the water-air interface behind the loosened paint film accelerates corrosive action. The prime coat further deteriorates and rust begins to form.

Even when zinc coated steel is used to provide corrosion resistance, manufacturers of hollow metal door and frame products have found that one week of product exposure to water, due to improper storage, can be equivalent to at least a year of outdoor exposure to the elements.

NOTE: Paint manufacturers advise that the primer typically used by hollow metal manufacturers should receive a finish coat of paint within 30 days of delivery. It is the responsibility of the General Contractor to sand, touch up and clean prime painted surfaces prior to finish painting in accordance with the finish paint manufacturer's instructions.

When storing hollow metal doors and frames at the job site the following procedures must be followed.

1. All material must be stored in a dry area. It must not be exposed to moisture.
2. Do not use non-vented plastic or canvas to cover hollow metal product. These materials trap moisture creating a humidity chamber, which promotes deterioration of the primer and corrosion of base metal.
3. Store doors and frames in an upright position. Figures 1 and 2

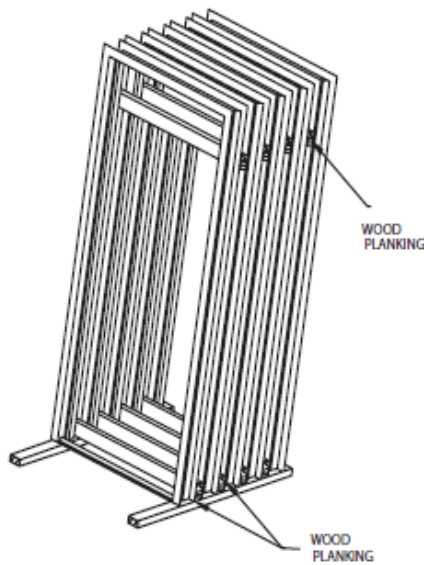

FIGURE 1
FRAME STORAGE

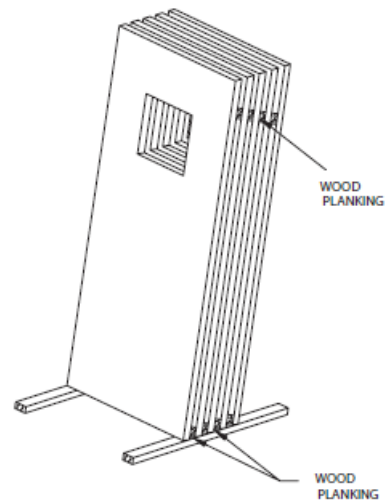

FIGURE 2
DOOR STORAGE

4. Place no more than 5 doors or 3-sided welded frames in a group to minimize the likelihood of damage due to excess handling. Special care and consideration must be given to multi-opening frames, transom, sidelight window assemblies and frames with special profiles.
5. Place all material on planking or blocking at least 4 in. (100 mm) off the ground, 2 in. (50 mm) off a paved area or the floor slab.
6. Provide space between all units to permit air circulation.

PART 3 - INSTALLATION OF FRAMES

3.01 GENERAL

Welded door frames are checked at the factory to ensure that they are square and free of twist during fabrication. Temporary steel spreaders are attached at the jamb bases to minimize misalignment or other damage during shipping and handling. The spreaders are for shipping and handling purposes only and must be removed before installing the frame.

At no time are the spreaders to be left in during installation.

In spite of precautions, frames can and sometimes do arrive at the job site with minor alignment deviations. It is normal that minor deviations from true form and alignment are to be corrected at time of installation by the contractor responsible.

Install hollow metal products using persons experienced and trained in the handling and installation of hollow metal products, having successfully accomplished installations of similar scope and size. They need to be able to read and understand architectural plans and specified hardware requirements.

3.02 PRIOR TO INSTALLATION

The installer is to perform the following prior to installation:

1. The area of the floor on which the frame is to be installed and the path of the door swing to be checked for flatness and levelness. Permissible tolerance is +/- 1/16 in. (1.5mm). If the floor exceeds this, it is the general contractor's responsibility to correct the area that is out of tolerance before the frame is installed.
2. Frame is to be checked for correct opening number, size, swing, material thickness, fire rating and hardware requirements. If product does not comply with contract documents do not install and contact supplier.
3. Remove temporary steel spreaders from welded frames. Marks caused by the removal of spreader bars to be restored and refinished using direct to metal primer.
4. When knock-down frames are used, the manufacturer's recommended assembly procedures must be followed.

3.03 INSTALLATION TOLERANCES

During the installation of the frame, check the opening width, opening height, squareness, alignment, twist and plumbness. Permissible frame product installation tolerances are to be maintained within the following limits: See Figure 3.

Opening width – Measured horizontally from rabbet to rabbet at top, middle and bottom of frame; + 1/16 in. (1.5 mm), -1/32 in. (0.8 mm).

Opening height – Measured vertically between the frame head rabbet and top of floor or bottom of frame minus jamb extension at each jamb and across the head; + 1/16 in. (1.5 mm) – 1/32 in. (0.8 mm).

Squareness – Measured at rabbet on a line from jamb, perpendicular to frame head; not to exceed 1/16 in. (1.5 mm).

Alignment – Measured at jambs on a horizontal line parallel to the plane of the face; not to exceed 1/16 in. (1.5 mm).

Twist – Measured at opposite face. Corners of jambs on parallel lines, perpendicular to the plane of the door rabbets; not to exceed 1/16 in. (1.5 mm).

Plumbness – Measured at jambs on a perpendicular line from the head to the floor; not to exceed 1/16 in. (1.5 mm).

These tolerances provide a reasonable guideline for proper installation of hollow metal frame product. However, it should be noted that the cumulative effect of the installation tolerances at or near their maximum levels could result in sufficient misalignment to prevent the door from functioning properly. Installers must be careful not to create a tolerance buildup. Tolerance buildup occurs when several tolerances are at or near their maximums. Care should be taken to keep deviation from each of these tolerances as close to zero as possible.

OPENING WIDTH, MEASURED HORIZONTALLY FROM RABBET TO RABBET AT TOP, MIDDLE AND BOTTOM OF FRAME + 1/16 IN (1.5 mm) - 1/32 IN (0.8 mm)

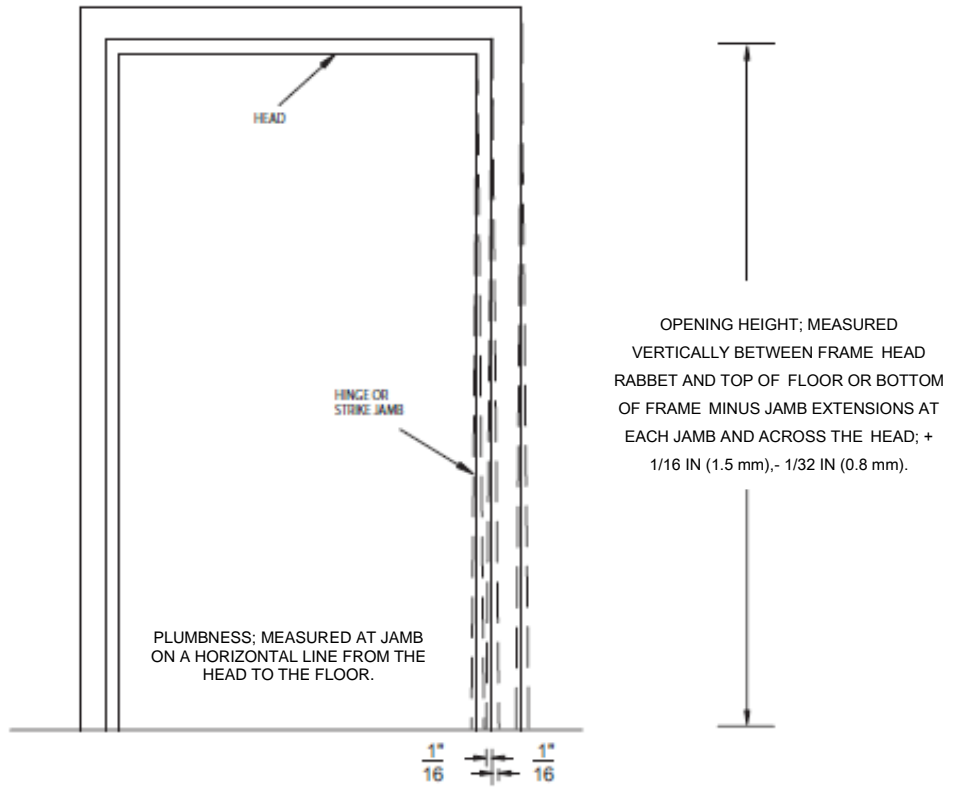
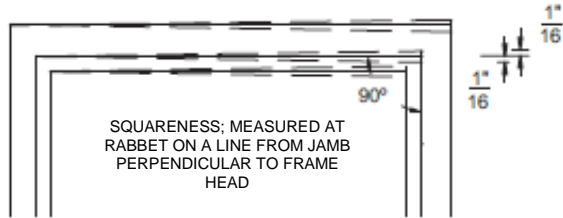

PROFILE MAY VARY AS A FUNCTION OF DESIGN

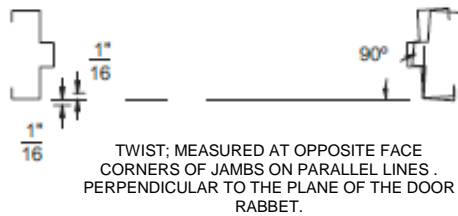
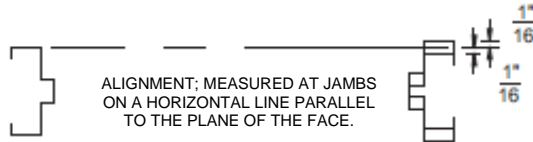

FIGURE 3
FRAME INSTALLATION TOLERANCES

3.04 TYPICAL INSTALLATION PROCEDURES, PRIOR TO WALL CONSTRUCTION

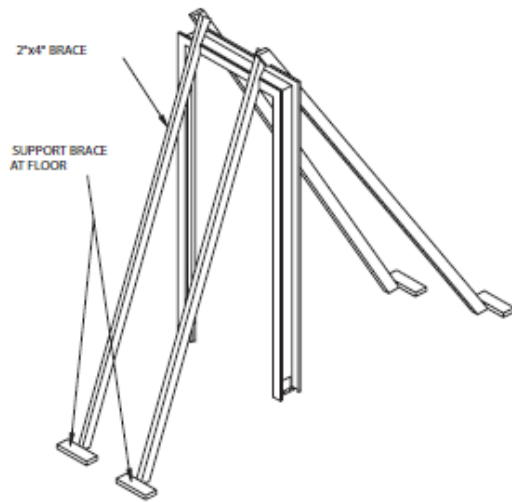

FIGURE 4
FRAME BRACING

Position frame in the correct location.

Brace the frame as shown, Figure 4. Do not brace in the direction of intended wall.

With frame in position, install the temporary wood spreaders. The wood spreader, Figure 5, must be square and no less than 1 in. (25 mm) thick. Correct length is the door opening width between the jambs at the header. Cut clearance notches for frame stops. Spreader must be nearly as wide as jamb depth for proper installation. Install a spreader at the bottom of the frame and a second at the mid height to maintain proper door opening width and to prevent bowing of the jambs during wall construction, Figure 6. Leave spreaders in place until the frame is set permanently in the wall.

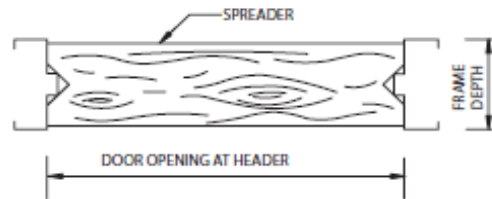

FIGURE 5
WOOD SPREADER

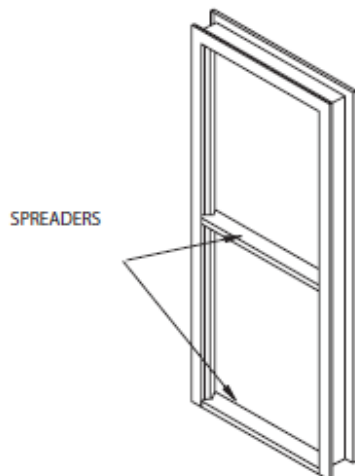
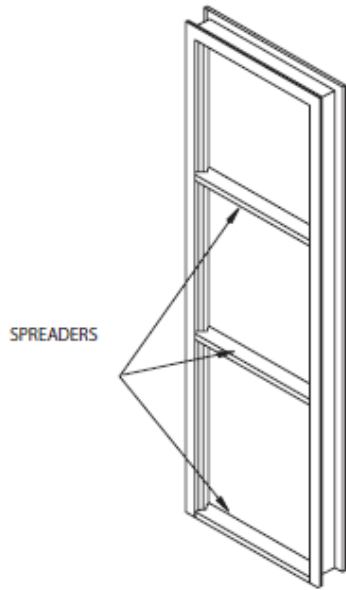

FIGURE 6
SPREADER LOCATION



Frames with jamb opening heights greater than 8 ft. (2438 mm) or frame face dimensions less than 1-1/2 in. (38 mm), require additional wood spreaders. Space the wood spreaders a maximum of 36 inches (914 mm) apart between header and bottom of frame, Figure 7.

**FIGURE 7
SPREADER LOCATION AT
LARGE JAMB OPENING HEIGHTS**

Frames with sidelights where the sidelight sill intersects the door jamb, it is imperative that a wood spreader is located at this location, Figure 8.

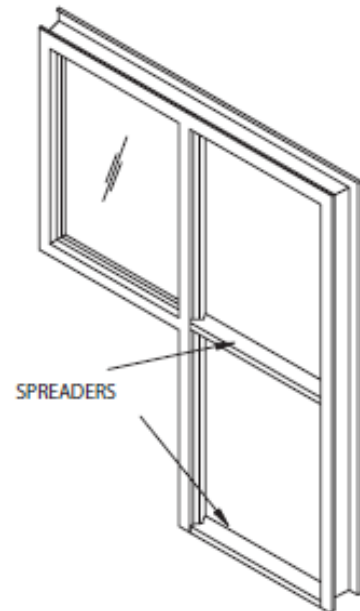

**FIGURE 8
SPREADER LOCATION AT SIDELIGHTS**

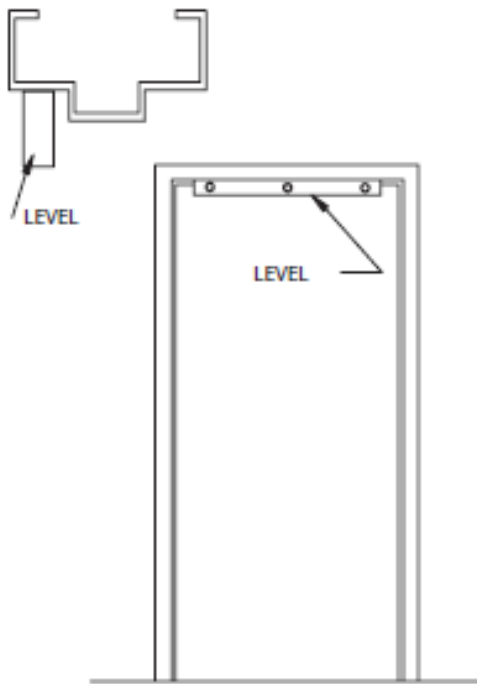

Level the head by positioning a level against the door rabet in head, Figure 9. If necessary, adjust for high spots in floor by shimming under the jamb or floor anchors if specified.

**FIGURE 9
LEVELING THE HEAD**

With framing square, check frame for squareness. Position square against jamb and head at door rabbets; adjust as required, Figure 10.

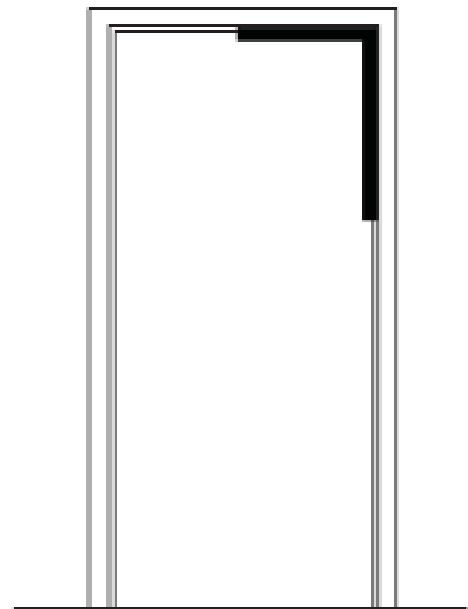

**FIGURE 10
SQUARENESS**

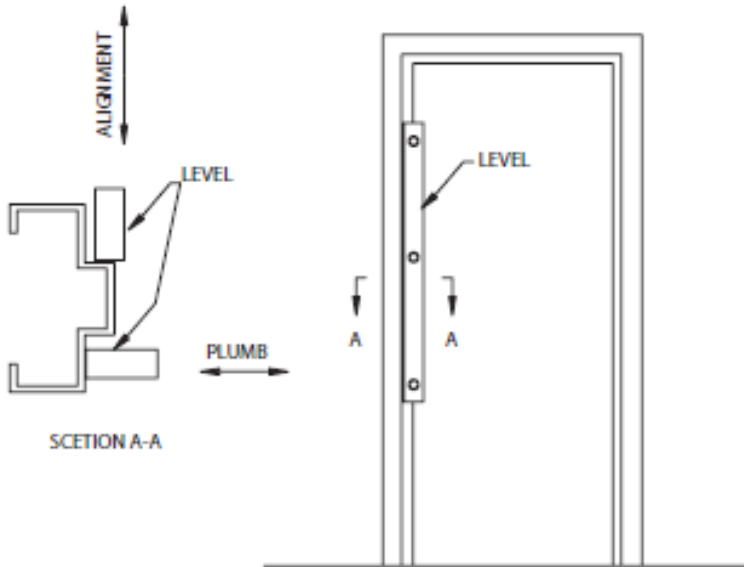
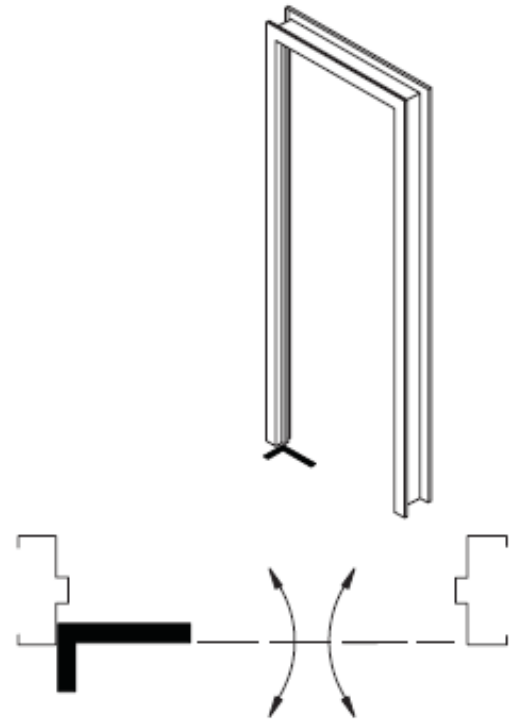

**FIGURE 11
PLUMBING AND ALIGNMENT**

With the level, check the frame for plumbness and alignment. For plumbness, position level against both hinge and strike jambs in the rabbet. For alignment; position level against both hinge and strike jambs on the stop, adjust as required, Figure 11.

With framing square, check jambs for twist. Position square against door rabbet and project line perpendicular to the plane of the door rabbet, adjust as required, Figure 12.

Once the frame is braced in the correct position anchor the floor anchors if provided



**FIGURE 12
FRAME TWIST CHECK**

3.05 FLOOR ANCHORS

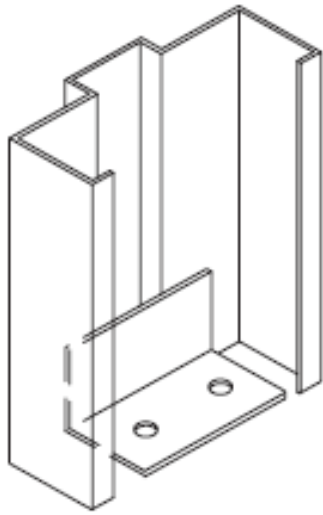

The fixed floor anchor, Figure 13A, is welded to the base of the jamb. This type of anchor is intended to be secured to the floor by mechanical fasteners. Shims must be used if the floor is not level. This floor anchor is not generally used in existing masonry, existing concrete, framed stud walls or slip-on drywall frames.

**FIGURE 13A
FIXED FLOOR ANCHOR**

The adjustable floor anchor is designed for use where there are unlevel floor conditions, an intended slope in the floor, or where toppings such as terrazzo are used, Figure 13B.

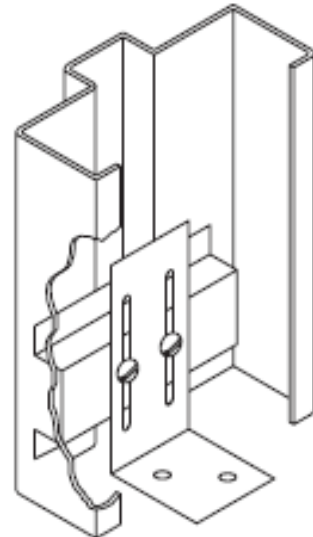

**FIGURE 13B
ADJUSTABLE FLOOR ANCHOR**

3.06 WALL CONSTRUCTIONS AND APPROPRIATE ANCHORS

Proper frame anchoring is vitally important to the long term performance of the door opening. A variety of anchors are available to suit various types of wall construction. Anchors shown on the following pages are but a few of the anchoring methods available. For additional details, refer to HMMA 820 Hollow Metal Frames.

- A. Anchor Spacing: HMMA specifications require that the number of anchors used on each jamb be as follows:
 - 1. Openings in Masonry Walls
 - a. Existing Masonry Openings: (Frames with expansion bolt anchors) Anchors will be spaced a maximum of 6 in. (152 mm) from the top and bottom of the opening, with intermediate spacing at a maximum of 26 in. (660 mm) o/c. See Table 1
 - b. Other Masonry Openings: Anchors will be spaced a maximum of 18 in. (457 mm) from top and bottom of openings. The minimum number of anchors will be per Table 1 with a maximum spacing between anchors of 32 in (812 mm).
 - 2. Openings in stud partitions with steel or wood stud anchors: Anchors will be spaced a maximum of 18 in. (457 mm) from top and bottom of openings near hinges and directly opposite on strike jamb. The minimum number of anchors will be per Table 1 with a maximum spacing between anchors of 32 in (812 mm).
 - 3. Anchor quantity for slip-on drywall frames is per manufacturer’s standards and label requirements.

Table 1
Minimum anchors per jamb

Frame Height	Existing Masonry Openings	Masonry Walls	Stud Partitions
> 0 in. < 60 in. (1524 mm)	3	2	2
> 60 in. < 90 in. (2286 mm)	4	3	4
> 90 in. < 96 in. (2438 mm)	5	4	5
> 96 in. (2438 mm)	5 + 1 per 24 in. (610 mm)	4 + 1 per 24 in. (610 mm)	5 + 1 per 24 in. (610 mm)

Notes: In stud partitions, a floor anchor may be substituted for a wall anchor.

Install fire rated frames per manufacturer’s instructions noting that anchor requirements may differ.

3.06.01 MASONRY WALLS

Installation of a hollow metal frame in masonry, Figure 14A.

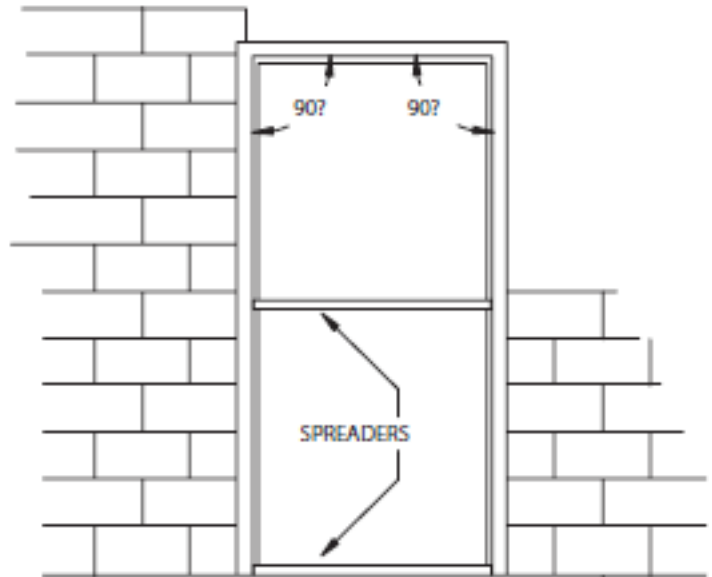

**FIGURE 14A
MASONRY WALL**

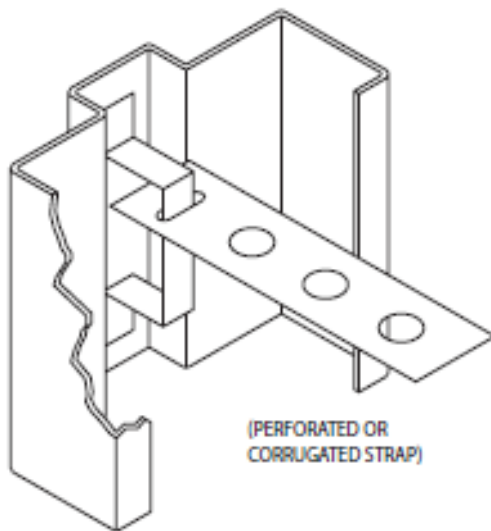

**FIGURE 14B
STRAP & STIRRUP ANCHOR**

The adjustable strap-and-stirrup masonry anchor, Figure 14B is made up of a stirrup welded inside the jamb, and a perforated or corrugated strap which provides for embedding into masonry joints. The stirrup allows for alignment to mortar joints as well as access for full grouting of jamps.

The t-strap anchor, Figure 14C and wire loop anchor, Figure 14D, function similar to the strap and stirrup anchor in that they are adjustable to align with mortar joints but are set loose inside the jambs, against the returns as the wall is constructed.

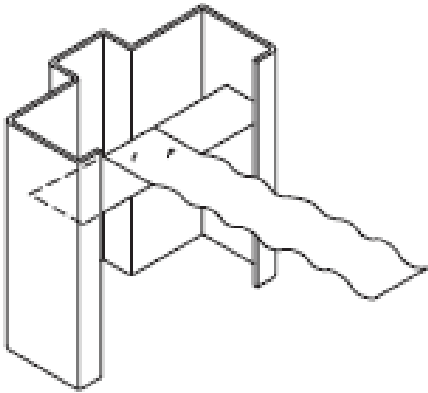

**FIGURE 14C
T-STRAP ANCHOR**



**FIGURE 14D
WIRE LOOP ANCHOR**

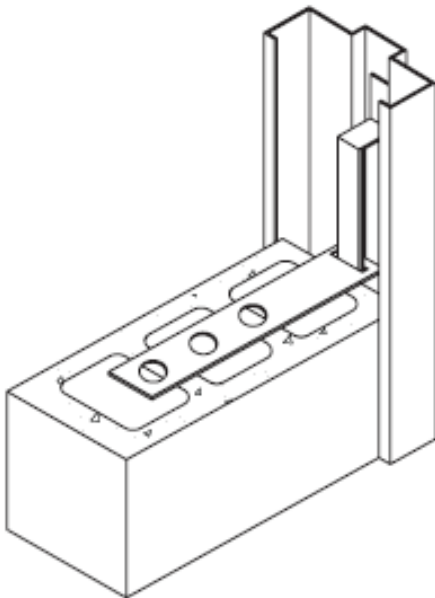

**FIGURE 14E
MASONRY WALL WITH ANCHOR**

As wall is constructed, locate the anchors at the hinges in the hinge jamb and at a corresponding position in the strike jamb, Figure 14E.

Continually check squareness, plumbness, alignment, and twist in the frame as wall progresses.

Refer to HMMA 820 Hollow Metal Frames for additional anchorage methods.

3.06.02 STEEL STUD WALLS

Installation of a hollow metal frame in steel stud wall, Figure 15A.

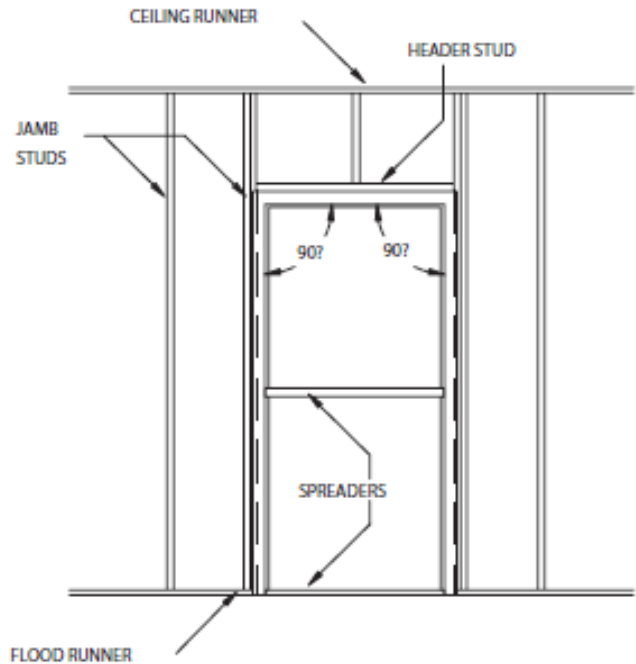

**FIGURE 15A
STEEL STUD WALL**

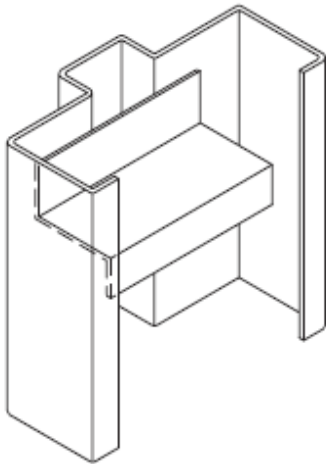

**FIGURE 15B
ZEE SHAPED STEEL STUD ANCHOR**

Zee shaped anchors, Figure 15B, are welded to both rabbets inside the jamb. They may also be welded in place vertically in lead lined frames to allow for the uninterrupted protection of the lead. Steel studs are mechanically fastened to the exposed flange through the throat of the stud.

Figure 15C shows the fastening of the steel studs to the anchors using sheet metal screws.

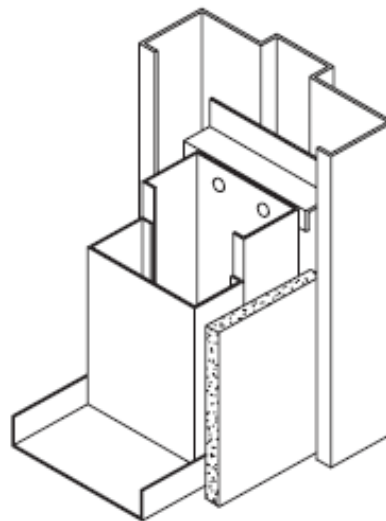

**FIGURE 15C
STEEL STUD WALL WITH
ANCHOR**

STEEL STUD WALL CONSTRUCTION

It is extremely important that the steel stud manufacturer's recommendations on thickness and general construction techniques be followed to ensure that a solid and stable opening is achieved.

Figures 16A and 16B represent methods of recommended or acceptable steel stud header connections to cripple studs above frame openings. Methods of connection shown in figures 16C and 16D are not recommended. Extreme caution must be taken to ensure that overlapping portions of the studs and fasteners applied through face of studs do not increase the wall thickness.

Continually check squareness, plumbness, alignment, and twist in the frame as wall construction progresses.

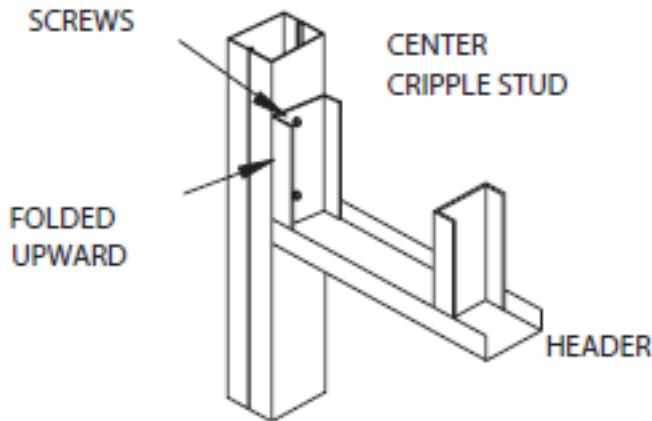

**FIGURE 16A
RECOMMENDED**

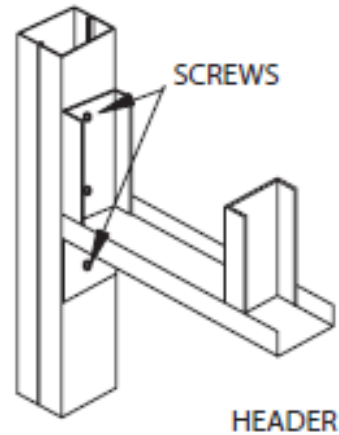

**FIGURE 16B
ACCEPTABLE**

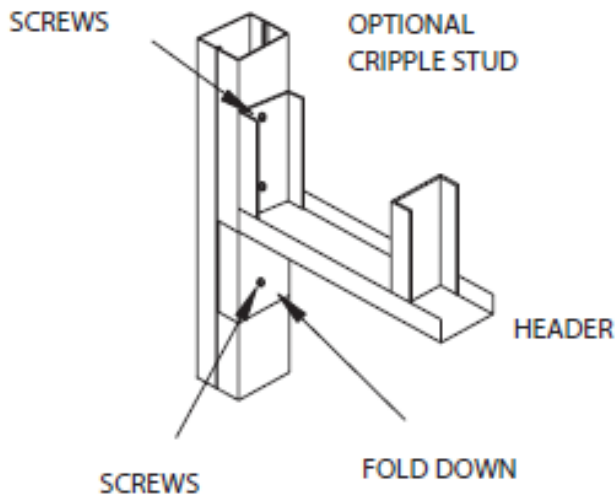

**FIGURE 16C
NOT RECOMMENDED**

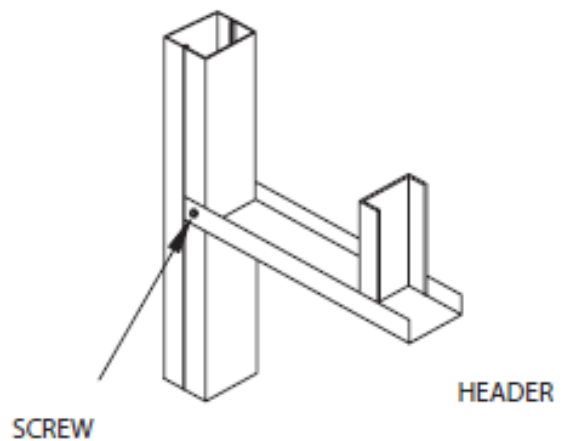

**FIGURE 16D
NOT RECOMMENDED**

3.06.03 WOOD STUD WALLS

Installation of a hollow metal frame in a wood stud wall figure 17A.

Wood stud walls can be constructed after the frame is set or prior to setting the frame. For constructing the wall after the frame is set, follow the same guidelines as for steel stud walls. For installing the frame in a framed wall, follow these guidelines:

With one of the horizontal straps bent back towards the face and against the return of the frame profile the frame can be slid into a properly sized rough opening.

Rough Stud Opening:

- A. The width of the opening is the overall frame width plus 1/2 in. (12.7 mm).
- B. The height of the opening is the overall frame height plus 1/4 in. (6.4 mm).

Place the frame in the rough stud opening. Bend the anchor tabs around the stud, leaving the desired clearance between the frame return and stud, for inserting the finished wall material. Set the spreaders and level, plumb and align the frame. Check for twist in jamb. Use shims to adjust as necessary

Square the frame at the top corner and nail the top anchor to the stud on ONE JAMB ONLY. Recheck the frame to ensure it is level, plumb and the alignment of the frame is correct then continue to nail the balance of the anchors to the studs. Repeat the same process for the opposite jamb.

Frames which are intended to be installed in a framed wall may be provided with an additional wall anchor in lieu of the floor anchor. This anchor is located as close to the bottom of the jamb as is practical.

Wood stud anchors, Figure 17B and 17C are welded to the back of the jambs.

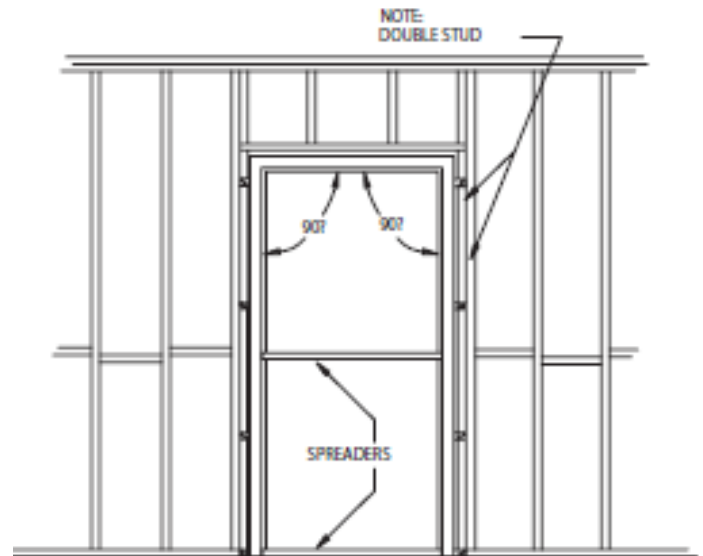

FIGURE 17A
WOOD STUD WALL

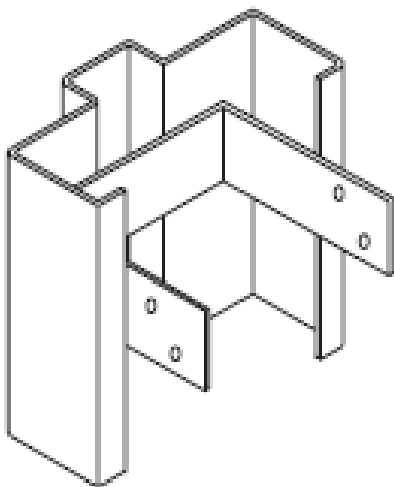

FIGURE 17B

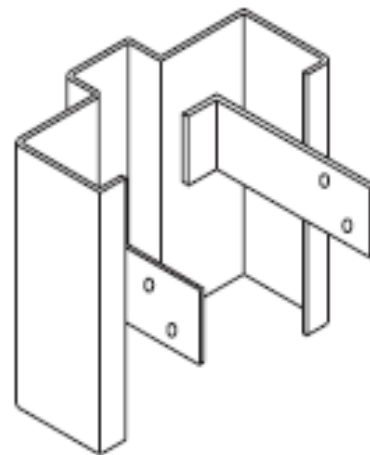
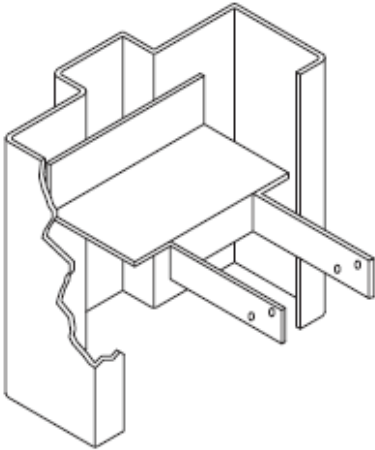
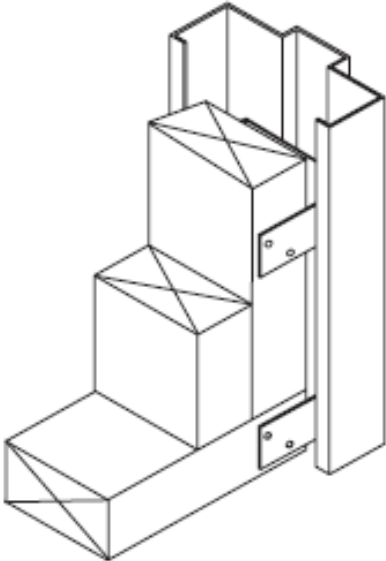

FIGURE 17C

Figure 17D shows an alternative wood stud anchor that is either welded to back of the jamb or friction fit. Figure 17E shows wood stud anchors fastened to wood stud wall construction. Refer to HMMA 820 Hollow Metal Frames for additional anchorage methods.



**FIGURE 17D
ALTERNATIVE WOOD STUD
ANCHOR**



**FIGURE 17E
WOOD STUD WALL WITH ANCHORS**

3.06.04 EXISTING MASONRY WALLS

When an opening exists in a wall prior to the frame installation, clearance between existing wall and frame is critical. Size the frame accordingly to allow for $\frac{1}{4}$ in. clearance between the returns of the frame and the rough opening. Take into consideration the minimum dimensions and the plumbness and levelness of the entire opening, including the floor.

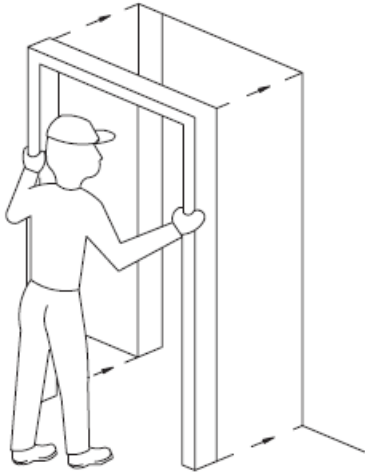

FIGURE 18A
EXISTING MASONRY WALL FRAME
INSTALLATION

Installation:

Place the frame in the completed wall opening, Figure 18A. Check for squareness. Mark the wall through the anchor holes provided in the jambs. Drill appropriate holes at the marks.

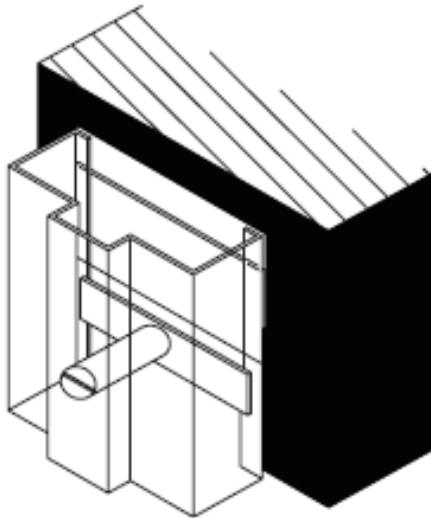

FIGURE 18B
EXPANSION BOLT INSTALLATION

Install frame:

Insert mechanical fasteners through frame soffit into existing wall, Figure 18B. Shim between the existing wall and the frame near the fastener locations. Depending on the anchor supplied shims can be placed between the returns and or the anchor and the wall. Ensure the frame remains plumb and aligned as fasteners are tightened. Caulk between frame and wall.

ROUGH BUCK FRAME:

A rough buck frame installation all but eliminates the need for shims. The rough buck is fastened tight to the existing wall, The finished frame is then fastened in place with face screws to the rough buck. Figure 18C.

Refer to HMMA 820 Hollow Metal Frames for additional anchorage methods.

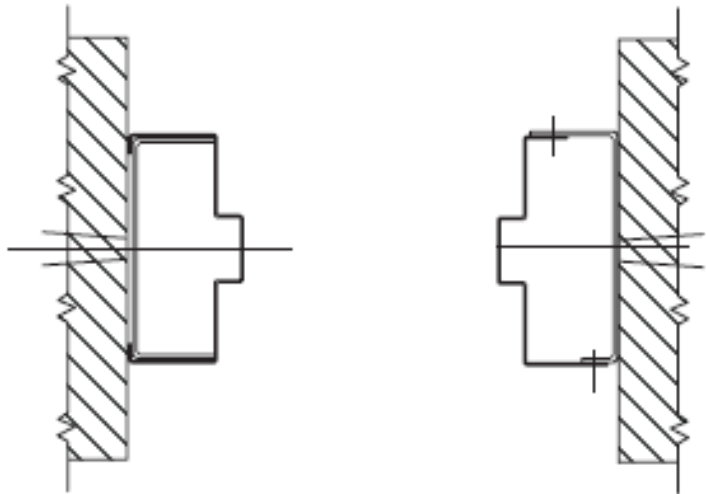

**FIGURE 18C
ROUGH BUCKS**

3.06.05 POURED IN PLACE OR TILT UP CONCRETE WALLS:

These types of construction methods normally have rough openings that are prepared in the forms prior to the pouring of concrete. Once concrete has cured frames are installed using expansion bolt anchors.

3.06.06 COMPLETED DRYWALL

It is very important that the stud manufacturer's recommendation on thickness and general construction techniques be followed to ensure that a solid and stable opening is achieved. For example, double studding at the opening is necessary; the header member must be the same width as the jamb stud. It is particularly important that the overlapping of vertical and horizontal steel members be avoided as this produces oversized walls. This could create significant installation problems and damage to wall material when slip-on drywall frames are used.

A variety of anchoring techniques preclude the establishment of a definite rough opening standard. Follow the frame manufacturers' recommendations.

Installation varies from manufacturer to manufacturer. Consult the supplying manufacturer's literature for exact instructions. A typical installation cycle may be as follows, Figure 19A.

1. Slide the header in place over the wall approximately in the center of the opening.
2. Install one jamb by sliding it over the wall at the top. Push the bottom of the member until it is approximately vertical.
3. Install the other jamb in a similar manner. The frame should be installed with all excessive rough opening clearances thrown to the hinge side. The weight of the door will tend to cause movement, within the opening, toward the strike jamb.
4. Join the header to the jambs, Figure 19B. This is normally done by inserting tabs into the slots, or screws into the holes or a combination of both.

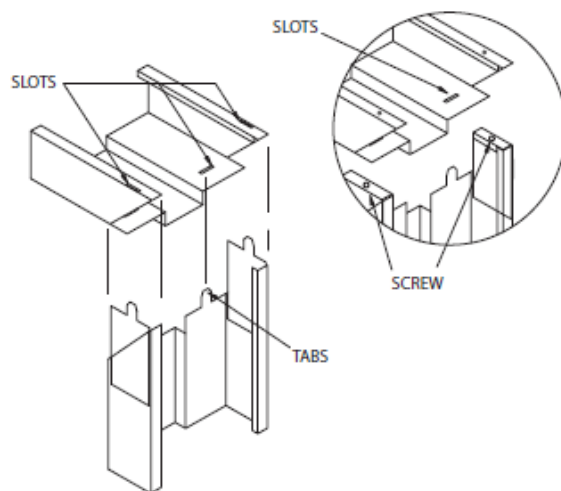

FIGURE 19B
CORNER CONNECTION
KNOCKDOWN SLIP-ON

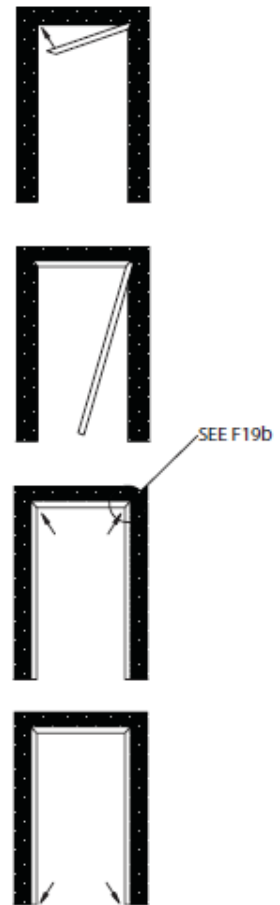

FIGURE 19A
INSTALLATION SEQUENCE

5. Plumb and square the opening and check the jambs for twist. Some installers prefer to hang the door at this point, permitting the door to aid in performing this function.

6. Attach the base anchor to the stud or floor channel at the base of the wall.

The base anchor is usually a strap of metal, provided either welded or loose at each side of the jamb at the bottom with holes punched for nails or screws, Figure 19C.

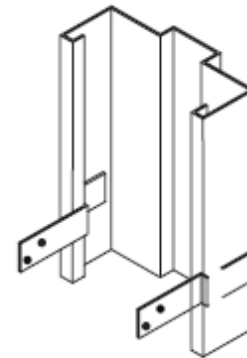

FIGURE 19C
SLIP-ON DRY WALL BASE ANCHOR

7. Set the compression anchor, Figure 19D. An adjustable compression device is normally located near the top of each jamb. This anchor is used on slip-on dry wall frames and in conjunction with slip-on dry wall base anchors. Consult manufacturer's literature for direction to turn compression anchor. Hand tighten the compression anchor, do not use a screw gun.

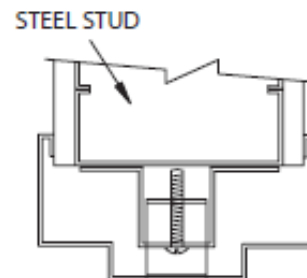
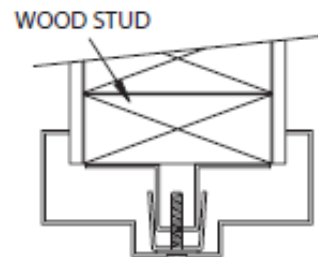

FIGURE 19D
COMPRESSION ANCHORS

3.07 GROUTING OF FRAMES

Grout guards and junction boxes are intended to protect hardware preparations and tapped mounting holes from masonry grout of 4 in. (100 mm) max. slump consistency which is hand troweled into place during wall construction. If a lighter consistency of grout (greater than 4 in. (127 mm) slump when tested in accordance with ASTM C143) is to be used, special precautions must be taken in the field by the installation contractor to protect the hardware preparations. Any grout or other bonding material must be promptly cleaned off of frames or doors following installation. Hollow metal surfaces are to be kept free of grout, tar or other bonding materials or sealers. Grouting materials which require air to dry (cure) are not recommended for such use in any closed section, such as a mullion.

When frames intended to be built into masonry construction are prepared for silencers, the silencer must be installed prior to grouting to avoid filling the silencer hole.

See Appendix HMMA –820 TN01-03 “GROUTING HOLLOW METAL FRAMES”

3.08 FIELD SPLICING

When shipping and/or handling limitations so dictate, frames for large openings must be fabricated in sections designed for splicing and welding in the field by others, Figure 20.

Splices will vary by manufacturer and installation circumstances. It is the responsibility of the installing contractor to use and finish the splices in accordance with the manufacturer’s recommendations.

Field splices at labeled frames require either a mechanical or welded connection at each splice joint. Mechanical fasteners are through the face of frame members. If splice joints are welded, welds are to be ground smooth and immediately cleaned and painted with a compatible, direct to metal (DTM), rust inhibitive primer. For products fabricated from zinc coated steel, use zinc rich rust inhibitive primer.

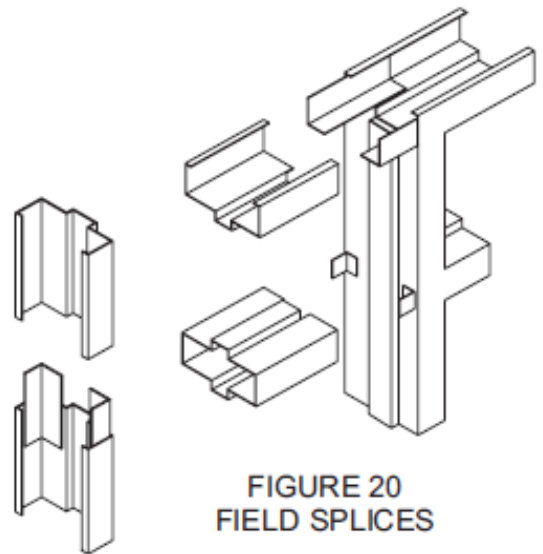

**FIGURE 20
FIELD SPLICES**

PART 4 - HANGING OF DOORS

4.01 GENERAL

It is the responsibility of the installer to hang all doors and install all hardware. Doors will be reinforced, drilled and tapped at the factory for templated mortise hardware in accordance with the approved hardware schedule and templates provided by the hardware supplier. Where surface mounted hardware, anchor hinges, thrust pivot, pivot reinforced hinges, or non-templated hardware apply, doors will be reinforced, for drilling and tapping done in the field by others.

Experienced craftsmanship and care are essential in the hanging of metal doors. The use of hinge shims may be required to provide uniform clearance around the door and alleviate "hinge bind".

Figures 21 & 22 indicate the locations of shims and their effect on the gaps between the door and frame.

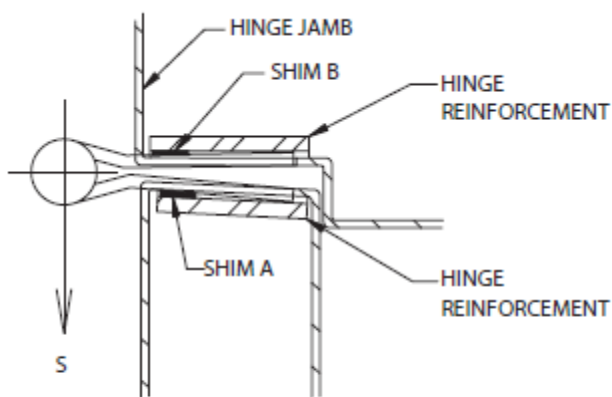

Figure 21

Using shim A only, door will be relocated in direction of arrow S.

Using shim B only, both door and centerline of hinge barrel will move in direction of arrow S.

Using both shims A and B will move the door further in direction of arrow S than by using either A or B alone, and hinge barrel will be relocated just as using B alone.

**FIGURE 21
SHIMMING TO INCREASE
CLEARANCE AT HINGE EDGE**

Figure 22

Using shim C only, door will be relocated in direction of arrow H.

Using shim D only, both door and centerline of hinge barrel will move in direction of arrow H.

Using both shims C and D will move the door further in direction of arrow H than by using either C or D alone, and hinge barrel will be relocated just as by using D alone.

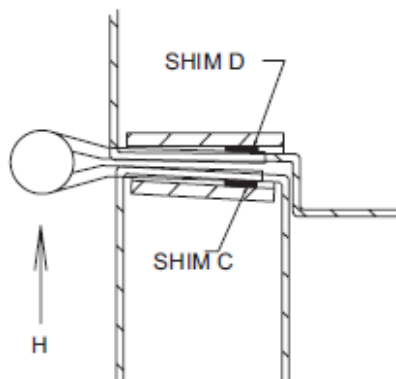

**FIGURE 22
SHIMMING TO DECREASE
CLEARANCE AT HINGE EDGE**

4.02 OPERATIONAL CLEARANCES

Edge clearances for swinging hollow metal doors and as specified in NFPA 80, provide for the functional operation of the assembly and must not exceed the following (for all door heights):

Between door and frame at head and jamb. 1/8 in. (3.1 mm) +/- 1/16 in. (1.5 mm)

Between edges of pairs of doors. 1/8 in. (3.1 mm) +/- 1/16 in. (1.5 mm)

Floor clearance for fire rated swinging hollow metal doors must not exceed 3/4 in. (19mm). Floor clearances provides for the functional operation of all swinging hollow metal doors and should not be less than 1/8 in. (3.1mm)

The Architect must define the distance from the top of the floor / finished floor to top of floor covering so appropriate undercuts can be provided. Floor / Finish Floor is defined as the top of the concrete or structural slab. HMMA uses the term "top of floor covering" to describe the NFPA term "nominal surface of floor covering". Please refer to HMMA-810 TN01-03 Tech Note, "Defining Undercuts".

4.03 CARE AFTER INSTALLATION

Doors installed prior to completion of construction may be subject to damage from other trades because of improper protection or carelessness.

Primed or painted surfaces which have been scratched or otherwise marred during installation (including field welding) and/or cleaning, are to be promptly finished smooth, cleaned and touched up with a direct to metal (DTM) rust inhibitive primer.

Acid washing of masonry construction adjacent to door and frame installations will damage the steel surfaces whether primed or finish painted.

If not cleaned immediately, rusting will occur. For this reason steel doors and frames must be protected. If exposed to an acid wash, all primed or painted steel surfaces must be thoroughly cleaned with particular attention being given to hidden areas such as those areas under glazing stops.

For additional information regarding the painting of hollow metal products, please refer to HMMA-840 TN01-07 Tech Note, "Painting Hollow Metal Products"

Grouting Hollow Metal Frames

Grout, when used in accordance with industry guidelines, can improve frame durability, sound deadening, and, depending on wall construction, increase frame anchorage strength. Grouting of the frame does not increase door durability, nor is it required for fire-rated frames. For most commercial applications, grouting of mullions and other closed sections is not recommended.

For applications covered by ANSI/NAAMM HMMA 862, "Guide Specifications for Commercial Security Hollow Metal Doors and Frames," and ANSI/NAAMM HMMA 863, "Guide Specifications for Detention Security Hollow Metal Doors and Frames," the standards require that "frame jambs shall be fully grouted to provide added security protection against battering, wedging, spreading, and other means of forcing open the door".

Grout is a water-based product. If not used properly, it can destroy the opening in a very short time. Grout can be either "mortar", which is a masonry mixture of lime, cement, sand, and water, or "plaster", which is a gypsum-based product.

Plaster grout dries by exposure to air. When a frame member is filled solid with plaster grout, only those areas exposed to air will dry and harden, while the center remains wet (uncured). The water remaining in the plaster grout can rust the frame from the inside. Plaster grout should not be used.

Mortar grout cures by chemical reaction and hardens throughout. Use mortar grout.

Frames are not designed to act as forms for grout. Grout must have a maximum 4 in. slump and be hand troweled in place. Bracing of the frame may be necessary prior to grouting to prevent sagging of the header or bowing of the jamb due to weight or pressure of the grout. Grout should not be installed after gypsum wallboard is installed, as the liquid within the grout will deteriorate the wallboard.

When dictated by temperatures, anti-freezing agents for mortar may be recommended by specifications. These agents can adversely affect metal, and all surfaces in contact with the grout must be coated with a corrosion resistant material.

It is recommended that the contractor be responsible for the grouting and for any required barrier coating. It is also his responsibility to use care in the application of the grout.

Defining Undercuts

Review of established definitions.

1. **"ACTUAL DOOR HEIGHT"** – The door opening height minus top clearance and undercut.
2. **"DOOR OPENING HEIGHT"** – The distance measured vertically between the frame head rabbet and top of floor or bottom of frame minus jamb extension.
3. **"FINISHED FLOOR"** – See "Floor"
4. **"FLOOR"** – The top of the concrete or structural slab.
5. **"FLOOR CLEARANCE"** – The distance between the bottom of the door and the top of the material directly below the door. This varies with application, such as concrete, any floor covering and/or a threshold.
6. **"FLOOR COVERING"** – Any material applied on top of the floor that extends under the door in its closed position or under the door as it swings to its fully open position.
7. **"UNDERCUT"** – The distance between the bottom of door and the bottom of frame. The formula in which to determine Undercut is derived by adding the total sum of the following (Floor Clearance + Floor Covering Thickness + Threshold Height (assuming the threshold is mounted on top of the floor covering) + Jamb Extensions Height).
8. **"JAMB EXTENSIONS"** – That portion of a jamb or mullion which extends below the level of the floor.

Typically frames are intended to be installed directly on the floor. When no floor coverings or thresholds are used, the dimension for "Undercut" is the same as for "Floor Clearance." See Figure #1.

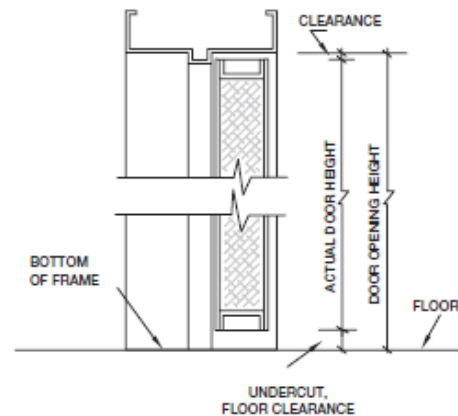

Figure #1

Floor coverings, such as carpet, resilient or ceramic tile, are typically installed on top of the floor, fitted around the frame, and under the door. In this situation, the formula for figuring Undercut is the total of the Floor Clearance + Floor Covering Thickness. See Figure #2.

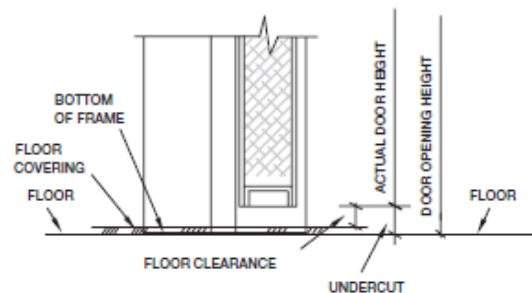

Figure #2

When a threshold is used, it is installed on top of the floor or floor covering, fitted around the frame and under the door. Again the formula for figuring "Undercut" changes. Undercut is the total of the

Floor Clearance + Threshold Height + Floor Covering Thickness. See Figure #3.

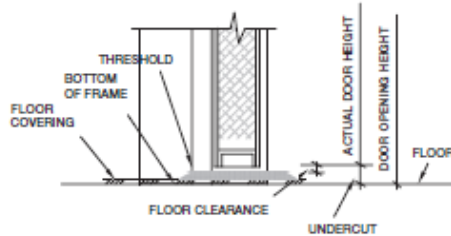

Figure #3

In situations with specialized floors such as thick ceramic tile or terrazzo, the frame is typically installed prior to the installation of the floor.

One method is to install the frame with adjustable floor anchors or for the frame to be installed on a block or shim. This allows the frame to be positioned, as required, to accommodate the floor height. See Figures #4A and #4B. Both illustrate a raised frame condition in which the bottom of frame is positioned to be directly on top of the floor after the floor is installed. In this situation, the dimension measured for Undercut is also the same as Floor Clearance.

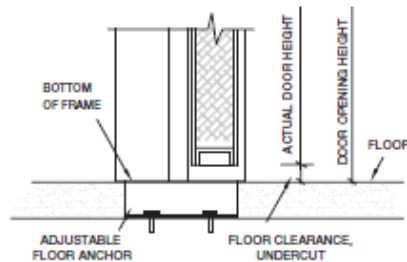

Figure #4A

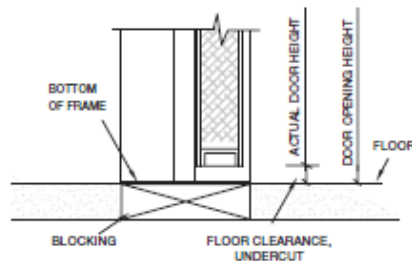

Figure #4B

Another method, called "below floor installation," is to install the frame directly on the rough slab. After the frame is installed, the floor is then installed around the frame. That portion of the

frame that is covered by the floor is called jamb extensions. The formula for figuring "Undercut" is the total of the Floor Clearance + Jamb Extensions. See Figure #5A and #5B.

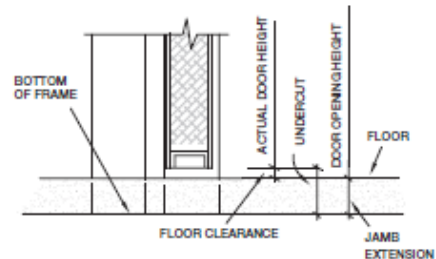

Figure #5A

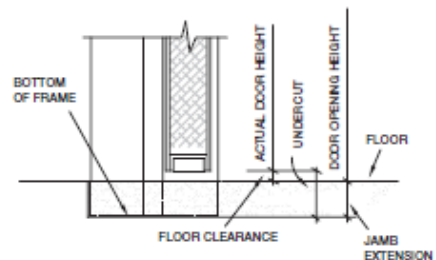

Figure #5B

The Architect/Designer must be very specific within specifications and contract drawings, which should include detailed drawings illustrating conditions for each floor, including thicknesses and materials. These drawings should designate the height at which the hollow metal frame should be set. Thresholds and hardware items requiring specific floor clearances shall be listed in the hardware schedule, which allows the door and frame manufacturer to properly size each opening.

Within the door and frame industry, both the Hollow Metal Manufacturers Association (HMMA) a division of the National Association of Architectural Metal Manufacturers (NAAMM) and the Steel Door Institute (SDI), publish recommended clearances. In addition, the National Fire Protection Association (NFPA) Publication 80, "Standard for Fire Doors and Fire Windows," regulates the installation and maintenance of labeled openings, and lists several different scenarios consisting of different floor material and the maximum clearance under the bottoms of doors.



HMMA-840 TN01-07



Painting Hollow Metal Products

Hollow metal doors, frames, and related products are fabricated from hot-rolled, cold-rolled, zinc-coated, or stainless steel. Stainless is typically not painted and therefore not referred to in this tech note. Hot and cold-rolled steel are supplied either dry or oiled and require treatment prior to painting. Zinc coated steel is either galvanized or galvanized. Galvanized steel is manufactured suitable for immediate painting without further treatment other than normal cleaning. Galvanized steel requires treatment prior to painting. Refer to HMMA 802, "Manufacturing of Hollow Metal Doors and Frames" for more information.

Hollow metal products must be stored in a manner to prevent exposure to adverse environmental elements. Refer to HMMA 840, "Guide Specifications for Installation and Storage of Hollow Metal Doors and Frames" for more information. Primer protects the uncoated base metal and provides the bonding agent required for the finished paint. It is very important that the primer is protected and cleaned prior to the application of the finish coat of paint. Primer manufacturers advise that the primer receive a finish coat within 30 days of delivery.

Exposure to elements, such as high humidity, salt air, snow, rain, damp wrappings, etc., without proper protection and air circulation, allows moisture to be absorbed by the primer. Once this occurs, with the presence of oxygen, an electrolytic action follows. Moisture travels between primer and the metal surfaces in a capillary action, deteriorating primer adhesion. Eventually this can result in water stains, rusting, flaking, lifting, or peeling. When paint flakes, lifts, or peels, rusting is not always evident. Typically these areas have not been in constant contact with the elements, but moisture has traveled under the primer.

Breakdown of the primer adhesion can be caused by incompatibility with the finish coat of paint resulting in the same conditions as listed above. Care must be taken to ensure compatibility of primer and any top coat. A small area test is always recommended to verify compatibility and adhesion. In some instances, a barrier coat between primer and top coat is necessary. Consult finish paint manufacturer's instructions.

Different paint problems have different solutions. Depending on the severity of the problems, sanding, sanding to bare metal, cleaning to remove contaminants, and re-priming can be necessary.

The selection of paint is also a consideration. Manufacturing marks are not always visible with a flat low gloss primer but can appear after a gloss finish coat is applied. The use of high gloss paint will increase the show through tendencies and is not recommended. A maximum paint gloss rating of 20 % reflectance, measured using a 60 degree gloss meter, would be the standard recommendation. Select a commercial direct to metal, (DTM) quality paint.

It is extremely important to follow the finish paint manufacturer's instructions. It is important to avoid painting in extremely hot, cold, or damp weather. Ensure material being painted is clean and dry. Prior to finish painting, lightly sand primed surfaces with fine grit sand paper or emery cloth.

RECOMMENDED GUIDE SPECIFICATIONS FOR HOLLOW METAL DOORS AND FRAMES

HMMA 800 Introduction to Custom Hollow Metal

HMMA 801 Glossary of Terms for Hollow Metal Doors and Frames

HMMA 802 Manufacturing of Hollow Metal Doors and Frames

HMMA 803 Steel Tables

HMMA 804 Quality Control Template for Hollow Metal Doors and Frames Manufacturers

HMMA 805 Recommended Selection and Usage Guide for Hollow Metal Doors and Frames

HMMA 810 TN01 Defining Undercuts

HMMA 810 Hollow Metal Doors

HMMA 820 TN01 Grouting Hollow Metal Frames

HMMA 820 TN02 Continuously Welded Frames

HMMA 820 TN03 Guidelines for Glazing Hollow Metal Transoms, Sidelights and Windows

HMMA 820 Hollow Metal Frames

HMMA 830 Hardware Selection for Hollow Metal Doors and Frames

HMMA 831 Hardware Locations for Hollow Metal Doors and Frames

HMMA 840 TN01 Painting Hollow Metal Products

HMMA 840 TN02 Maintenance of Installed Hollow Metal Products

HMMA 840 Guide Specifications for Installation and Storage of Hollow Metal Doors and Frames

HMMA 841 Tolerances and Clearances for Commercial Hollow Metal Doors and Frames

HMMA 850 Fire Rated Hollow Metal Doors and Frames

HMMA 860 Guide Specifications for Hollow Metal Doors and Frames

HMMA 861 Guide Specifications for Commercial Hollow Metal Doors and Frames

HMMA 862 Guide Specifications for Commercial Security Hollow Metal Doors and Frames

HMMA 863 Guide Specifications for Detention Security Hollow Metal Doors and Frames

HMMA 865 Guide Specifications for Sound Control Hollow Metal Door and Frame Assemblies

HMMA 866 Guide Specifications for Stainless Steel Hollow Metal Doors and Frames

HMMA 867 Guide Specifications for Commercial Laminated Core Hollow Metal Doors and Frames

HMMA 890 Technical Summary